



1	COMPONENTS FOR CENTRAL HEATING SYSTEM	
2	HYDRAULIC SEPARATORS, DISTRIBUTION MANIFOLDS AND PUMPING STATIONS FOR CENTRAL HEATING	
3	DIRT SEPARATOR FILTERS AND AIR VENT VALVE	
4	ADJUSTMENT AND MANAGEMENT DEVICES	
5	BALANCING DEVICES	
6	COMPONENTS FOR PLUMBING SYSTEMS	
7	ANTI-POLLUTION DEVICES	
8	"TIEMME BOX" FLUSH-MOUNTED MODULES FOR ONE RADIANT AREA ADJUSTMENT	
9	COMPONENTS FOR SOLAR THERMAL SYSTEMS	
10	DIRECT METERING - UTILITIES MODULES	
11	DIRECT METERING - METERS	
12	INDIRECT METERING - HEAT COST ALLOCATORS	
13	TEMPERATURE CONTROLS	
14	DATA COLLECTION AND READING SYSTEMS	

**DISCOVER THE
TIEMME RANGE
AND DOWNLOAD THE
TECHNICAL DOCUMENTATION**



“Everyone, with their skills and experience, has always been essential to our company. It is something precious that paves the way to a better understanding of all Customers’ need, be them in Italy or abroad, through targeted and innovative services and products”.

The President

Giuliano Gnutti

A handwritten signature in black ink, appearing to read 'Giuliano Gnutti', written in a cursive style.



The Gnutti Cirillo Group has been a leading entrepreneurial business from the 50s, with a well-rooted activity all over the territory. A cluster of companies leaders in the technical-production chain, turning raw material into a fine product. A perfect union between tradition, professionalism, quality, technology and know-how, so to offer the best service, every day.

The Gnutti Group was conceived from the development and growth of the company Gnutti Cirillo S.p.A.



TIEMME Raccorderie was founded 80s as a manufacturer and distributor of fittings, brass valves and pipes. In the 1994 it joined the Gnutti Group, when the company was facing a radical change. The 2000s represent a phase of further growth and evolution for the company through the development of integrated systems in the HVAC industry. In 2012, "Tiemme Lab" was founded in Castagneto - an innovative laboratory for heat technologies. The branches in Spain, Greece and Romania are intended to respond to an increasingly vast and demanding market, directing the company to an internationalization perspective.



Gnutti Cirillo S.p.A. is the parent company, founded in 1951 by Cirillo Gnutti as a mechanical company for the manufacture of equipment and molds, today world leader in hot molding and mechanical processing of brass and other non-ferrous metals. Thanks to an efficient and competent management, Gnutti Cirillo S.p.A. can meet any demand through a self-sufficiency production chain. Starting from the design, through the construction of the equipment and tools, the hot stamping of brass, the machining, the surface treatments, the automatic assemblies until the packaging of the finished product; everything is proudly carried out within the group with possible customization following the customer's specifications. In 2000 the Odolo (BS) plant was added to the historic headquarters in Lumezzane (BS).



Over the years, the group's internationalization process went on and on with the creation of **Metal Forming Technology Inc.** Located in Michigan, MFT has achieved high standards of efficiency in the production of hot-stamped brass items processed following customer specifications. The company also acts as a logistics and customer care center for Gnutti Cirillo S.p.A. for the North American and Canadian markets.



EMC Component is a company founded in 2011, specializing in the design, production and marketing of accessories for power and distribution transformers.



UNI EN ISO 9001:2015



RETTORATO DI CERTIFICAZIONE
CENTRO NAZIONALE

The company is based in Castegnato (Brescia) and operates in two adjacent plants, one of approximately 7.000 m² covered, where the production department with transfer machines and offices are located, the other with an area of 15.000 m² where the warehouses and the PEX department for the production of the cross-linked polyethylene pipe are located.

Tiemme Raccorderie® Quality System is the tool to make sure that all customers get products and services meeting their expectations for constant high quality and punctuality in delivery, in a process of continuous improvement, in full respect of safety and the environment.

In 1999 TIEMME Raccorderie® S.p.A. obtained the ISO 9002 certification of its quality system and in 2003 the ISO 9001 certification, natural consequence of the total quality policy and achievement of the excellence as pursued by the company. Addition to the high-quality manufacture, Tiemme Raccorderie® products are tested, controlled and recognized all over the world by more than 70 of the most prestigious certification bodies. Efficient and modern service of trained technicians is fully available to our customers.

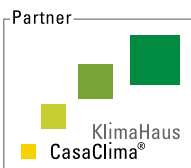



ROMANIA

Branch office
Bucharest

SPAIN

Branch office
Valencia

ITALY

TIEMME RACCORDERIE SPA

GREECE

Branch office
Athens

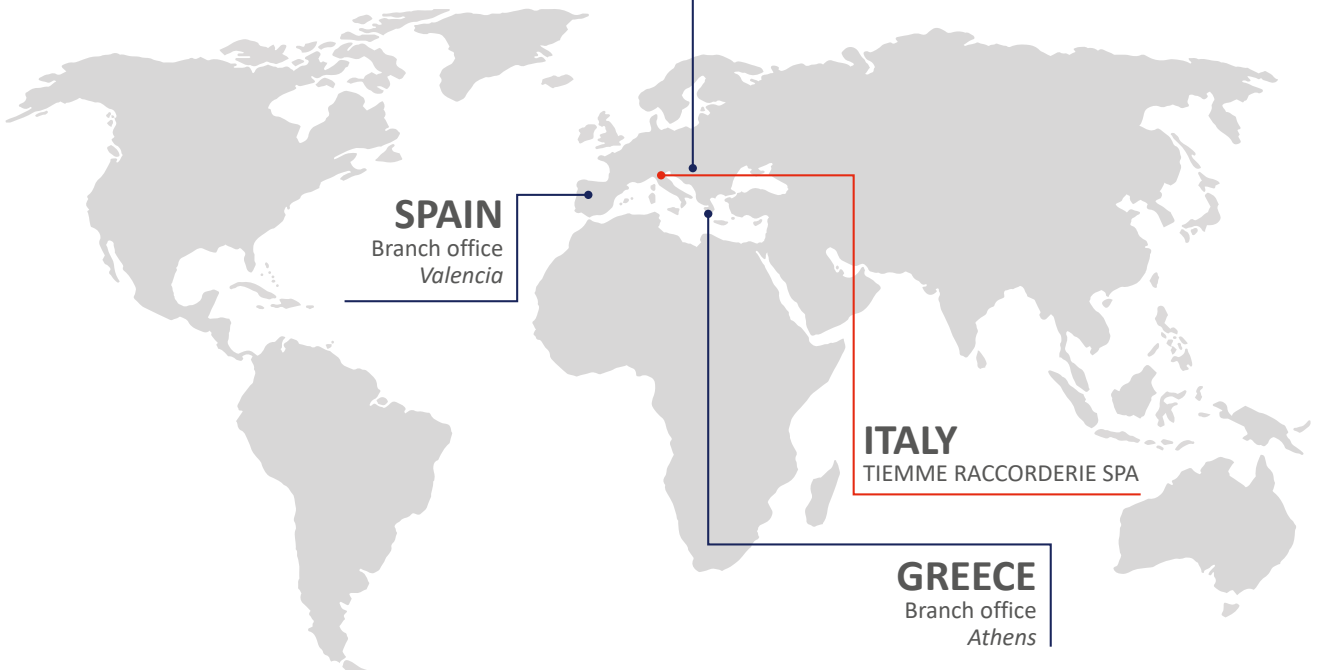



TIEMME, CERTIFIED QUALITY

		ITALY RINA REGISTRO NAVALE ITALIANO			BELGIUM FEDERATION REPRESENTING THE PUBLIC SERVICES OF DRINKING WATER AND WASTE WATER
		ITALY POLITECNICO DI MILANO FONDAZIONE LABORATORIO PROVE MATERIE PLASTICHE			UKRAINE ORGANO DI CERTIFICAZIONE CCV "TYSK"
		ITALY ISTITUTO GIORDANO			SLOVAKIA TECHNICKY SKUSOBNY USTAV
		ITALY ICIM			CZECH REPUBLIC VYZKUMNY USTAV POZEMNICH STAVEB – CERTIFIKACNI SPOLECNOST S.R.O.
		ITALY ISTITUTO NAZIONALE ASSICURAZIONE INFORTUNI SUL LAVORO			CZECH REPUBLIC STROJIRENSKY ZKUSEBNÍ ÚSTAV
		GERMANY DEUTSCHER VEREIN DES GAS-UND WASSERFACHES			RUSSIA NASHOL CERTIFICATION CENTER CC
		AUSTRIA ÜA HYGIENE CERTIFICATE			RUSSIA HYGIENE CERTIFICATE
		DENMARK ETA - DANISH BOARD OF EUROPEAN TECHNICAL APPROVAL FOR CONSTRUCTION PRODUCTS			RUSSIA EAC CERTIFICATE
		DENMARK CERTIFIKAT 03-00012			POLAND PANSTWOWY ZAKLAD HYGIENY NATIONAL INSTITUTE OF HYGIENE
		DENMARK DTI ENERGY DANSK TEKNOLOGISK INSTITUT			POLAND INSTYTUT TECHNIKI BUDOWLANS
		NORWAY NORWEGIAN BUILDING RESEARCH INSTITUTE			HUNGARY EPITESUGYI MINOSEGELLENORZO INTEZET INSTITUTE FOR QUALITY CONTROL OF BUILDING
		SWEDEN SWEDISH INSTITUTE FOR TECHNICAL APPROVAL IN CONSTRUCTION			UNITED KINGDOM BRITISH GAS TECHNOLOGY
		FINLAND YMPÄRISTÖMINISTERIÖN TYYPPIHYVÄKSYNTÄPÄÄTÖS THE FINNISH MINISTRY OF ENVIRONMENT			UNITED KINGDOM WATER REGULATION ADVISORY SCHEME
		SPAIN AENOR			FRANCE LABORATOIRE SANTÉ ENVIRONNEMENT HYGIÈNE DE LYON
		HOLLAND CENTRUM VOOR GASTECHNOLOGIE			FRANCE CENTRE SCIENTIFIQUE ET TECHNIQUE DU BÂTIMENT
		HOLLAND CERTIFICATIE EN KEURINGEN			FRANCE CERTIFICATION NF
		PORTUGAL ASSOCIAÇÃO PARA A CERTIFICAÇÃO DE PRODUTOS			BELARUS INSTITUTE
		ROMANIA AGREMENT TEHNIC ÎN CONSTRUCTII ROMÂNIA			IRELAND IRISH AGREEMENT BOARD BUILDING PRODUCT CERTIFICATION
		BULGARIA TUV RHEINLAND BULGARIA LTD.			SERBIA INSTITUTE
		AUSTRALIA WATERMARK LICENCE			EUROPE MARCHIO CE DI PRODOTTO
		AUSTRALIA OCEANA MARK			VIETNAM TESTING CENTER 3
		BELGIUM UNIVERSITE LIBRE DE BRUXELLES			SOUTH AFRICA AENOR



3154

TM-MAG EVO Under-boiler magnetic dirt separator filter with by-pass

PAGE 60



3155

TM-MAG EVO Proportional dispenser of polyphosphates in crystals with shut-off valve and integrated filter supplied with recharge

PAGE 64



3157KIT

2 pieces kit: Under-boiler magnetic dirt separator filter TM-MAG EVO and Proportional dispenser of polyphosphates ULISSE

PAGE 64



3156

TM-NEUTRIX Acid condensate neutralizer filter supplied with refill (2 bags)

PAGE 65



1898KIT34

Kit automatic air vent valve with body Ø34 mm (purge on side) + cut-off valve

PAGE 69



3177XSUN

Safety group suitable for hot water storage heaters for solar thermal systems

PAGE 162

INDEX

ART	PAGE	ART	PAGE	ART	PAGE	ART	PAGE	ART	PAGE	ART	PAGE
331GKIT	248	1557SET	55	1927	11	3004X	165	3177XSUN ■	158	4491	150
331HKIT	248	1564FD	172	1927M	12	3005X	165	3180	132	4491C	150
332GKIT	248	1570	81	1927MAN	12	3007KB	165	3180C	23	4492	151
332HKIT	248	1572FD	172	1927SUN	158	3011X	164	3180C	132	4492C	151
475KIT	161	1581FD	171	1928	11	3015	165	3200X	167	4601	257
475KITISOL	161	1602	46	1928MAN	13	3100N	131	3201KB	167	4606	257
0700X	176	1652	46	1929	21	3107N	131	3201X	167	4607	258
0705COL	176	1665	46	1935	140	3108N	131	3202X	167	4612	258
0720X	176	1665	55	1937	203	3110N	131	3203KB	168	4625D	256
1001	170	1725AL	16	1940	198	3111	132	3204X	167	4723CENTR	139
1003	171	1725OT	16	2074MAX	20	3120N	127	3205X	167	4723KIT	138
1005	171	1828Z	46	2074MIN	20	3130N	126	3211X	167	4730V	163
1007	172	1859	46	2075	20	3131N	126	3302KIT03	250	4731ANTIG	163
1014	173	1878	173	2075	230	3135N	126	3302KIT04R	249	4732	85
1015	173	1880	202	2075KIT03	54	3136N	126	3303KIT03	250	4733	135
1035	173	1881	46	2076	20	3140	127	3303KIT04R	249	4734	135
1039	172	1882	202	2077	20	3141	63	3307KIT03	250	4735E	155
1039J	174	1896	67	2078	20	3142	61	3307KIT04R	249	4736SONDA	155
1039S	174	1896GG	67	2079	20	3144	33	3308KIT03	250	4737	134
1040S	174	1898	69	2080	14	3144ISOL	33	3308KIT04R	249	4737SUN	159
1040T	174	1898G34	69	2080	132	3144MAG	33	3350	71	4738	134
1100FD	170	1898KIT34 ■	69	2080POST	14	3145	127	3351	71	4738G	134
1101	170	1899	69	2080POST	132	3146	61	3352	71	4738GSUN	159
1102FD	170	1900	69	2081	14	3147	61	3353G	175	4738KIT	134
1103	171	1900G	69	2082E	21	3148	62	3500	143	4738KIT	159
1104FD	171	1900G34	70	2082KIT	21	3149	62	3501	146	4738KR	136
1105	171	1900KITSUN	157	2082R	21	3150	59	3506	143	4738SUN	159
1107	172	1900KITSUN	175	2095R	46	3154 ■	60	3506SUN	157	4739	134
1113KB	174	1900N34	70	2121CP	46	3154C ■	60	3510	144	4739SUN	159
1114	173	1900SUN	157	2121CP	203	3155 ■	64	3600	143	4744	154
1115	173	1901	71	2130DIM	78	3155POL ■	64	3606	143	4745	154
1116	173	1901P	71	2130ISOL	78	3156 ■	65	3660	144	4745C	155
1117FD	175	1901PN	71	2130KIT	78	3156CAR ■	65	3665	144	4745E	154
1118	175	1913	68	2130SM	78	3157KIT ■	64	3670	128	4745MANOP	54
1119FD	175	1913G	68	2130STAF	78	3160K	22	3670CZISO7	128	4745MANOP	156
1133	171	1914	68	2133	76	3161	23	3670PS	236	4745R	154
1135	173	1916	13	2134	76	3162	121	3681	144	4746	163
1138	172	1916SUN	158	2134SUN	163	3163	24	3880GPF	54	4746KIT	163
1139	172	1917	11	2136	76	3163CA	27	3880GSM	54	4747	155
1147	173	1917M	12	2137	76	3163CC	27	3890P	55	4748D	155
1521CPKIT	81	1917MAN	12	2138	76	3163CR	27	3890PG3	156	4749E	156
1521CPKIT	85	1917SUN	158	2139	76	3164	26	3890PG4	156	4749FLOW	155
1521CPKIT	134	1918	11	2162SUN	157	3164CA	26	3890PU	55	4749FLOWE	155
1521CPKIT	159	1918MAN	13	2330SUN	157	3164CD	26	3890PV	55	5530E	82
1522	236	1919	21	2331SUN	157	3164RA	26	3890PW2	55	5530E1	83
1522	241	1921OG	15	2371SUN	157	3164RD	26	3890PW4	156	5530E2	83
1551FD	170	1921OM	15	2991SUN	157	3165	32	3890PW5	55	5530I9	83
1552FD	46	1921OP	15	3000X	164	3165ISOL	32	3890TTVD	81	5530I10	83
1552FD	170	1923	19	3001KB	164	3167ISOL	32	3890VD	81	5530M5	82
1552FDR	170	1923FL	19	3001X	164	3170	23	3894VDSUN	162	5530M6	82
1552SET	169	1924	19	3002X	164	3175CT	14	4490	149	5530P	82
1553FD	171	1925	17	3003KB	165	3175ISOL	14	4490C	149	5530P	138

■ New product

INDEX

ART	PAGE	ART	PAGE	ART	PAGE	ART	PAGE	ART	PAGE	ART	PAGE
5530P	230	6501I	211	6535DN	93	6561E	194	6570C	241	9574	254
5532HYBRID	75	6502C01	181	6535DNISOL	119	6561E	204	6575C	194	9575	254
5532PDC	74	6502C01-3C	181	6535DNMANOP	119	6561E	209	6575C	204	9580	254
5534G	52	6502C01DUO	182	6535ET	120	6561E	217	6575C	241	9580W	257
5534G3P	53	6502C01DUO-3C	182	6535G	93	6561E	229	6577A	265	9581	254
5535DIFF	54	6502C01DUODYN	188	6535ISOL	119	6561E	237	6578C	264	9589	260
5535G	47	6502C01DUO-		6535PP	119	6561E	240	6578C	265	9590	260
5535G3P	49	DYN-3C	188	6536	120	6561HR	184	6580C	246	9591	260
5535GPF	48	6502C01DYN	187	6538	113	6561HR	190	6580CS	246	9592	260
5536G	50	6502C01DYN-3C	187	6539	113	6561HR	204	6582	269	HEAT-EVO1	221
5536GS	51	6502C01TRIO	182	6540	118	6561HR	209	6582	270	HEAT-EVO1DYN	223
5537KIT	54	6502C01TRIO-3C		6541CC	96	6561HR	217	6582R	270	HEAT-EVO2	221
5538G2M3	40	182		6541DN	106	6561HR	229	6582RIC	269	HEAT-EVO3	222
5538G2M4	40	6502C01TRIO-		6542ATT	120	6561HR	237	6582RIC	270	HEAT-EVO4	222
5538G3M4	40	DYN-3C	188	6542CC	98	6561MM	237	6583MR	238	SCMEM	264
5538G3M6	40	6502G03	183	6542CCS	103	6561MM	240	6583MR	238		
5538G4M6	41	6502G03DYN	189	6542PP	119	6561MR	184	6583MR	239		
5538G4M8	41	6502G03DYNU	189	6542SERV	120	6561MR	190	6583MR	240		
5538X	37	6502G03U	183	6542SERV2	120	6561MR	194	6583S	239		
5539X	37	6502I	185	6543CH	119	6561MR	204	6583S	240		
5540G2M4	41	6502IDYN	191	6544DN	111	6561MR	209	7166	35		
5540G3M4	41	6502K	185	6544DNSERV	120	6561MR	217	7167	35		
5540G3M6	42	6502K	191	6545CH	119	6561MR	229	7169	19		
5540G4M6	42	6502KP	183	6560C	203	6561MR	237	8930IM	169		
5540G4M8	42	6502KPDYN	189	6560C	224	6561MR	240	8930SET	169		
5540G5M6	42	6502LS	183	6560C	228	6561RIC	268	9341SET	169		
5540G5M10	43	6502LS	189	6560C	233	6561RICUSB	268	9535	76		
5540G6M8	43	6502T	185	6560CUW	203	6561RS	240	9536	77		
5540G6M12	43	6502TDYN	191	6560CUW	224	6561TUSB	236	9537	76		
5540G7M8	43	6503C01	219	6560CUW	228	6561TUSB	246	9538	78		
5540G7M14	44	6503G03P	219	6560CUW	233	6562D	238	9551	252		
5540X	37	6506C02	226	6560CW	203	6562T	198	9553	252		
5540X	37	6506C03	226	6560CW	224	6562T	208	9553AM1	252		
5570	70	6506C04	227	6560CW	228	6562T	216	9553AM2	252		
6500C0125V2	206	6506C05	227	6560CW	233	6562T	234	9553C	252		
6500C0125V3	206	6506I2M	230	6561C	184	6563CC130	234	9553CHT	252		
6500C0132V2	207	6506I3M	230	6561C	190	6563CF	239	9553INS	252		
6500C0132V3	207	6509IBY	202	6561C	204	6564C	198	9556	252		
6500G02DN25	196	6509IMN	202	6561C	209	6564C	208	9556USB	252		
6500G02DN32	197	6509IRT	202	6561C	217	6564C	216	9556W	258		
6500G03DN25	196	6509IT	202	6561C	229	6564C	236	9558	252		
6500G03DN32	197	6509K	202	6561C	237	6565SA	236	9561KIT02	54		
6500I	198	6509KBY	202	6561CR	184	6565SB	198	9561T	175		
6500I	208	6509KT	202	6561CR	190	6565SB	208	9561TT	230		
6500I	216	6509MN	200	6561CR	204	6565SB	216	9562	230		
6501C0120	211	6509RT	200	6561CR	209	6565SB	236	9562P	81		
6501C0125V2	214	6509SNC	201	6561CR	217	6567C	236	9562P1	138		
6501C0125V3	214	6509SNF	201	6561CR	229	6568C	203	9562SERV	54		
6501C0132V2	215	6510P01	194	6561CR	237	6568C	224	9567	255		
6501C0132V3	215	6512P01	193	6561D	238	6568C	228	9568	255		
6501G02	211	6531G	156	6561E	184	6568C	233	9568VD	81		
6501G03	211	6534G	86	6561E	190	6569CW	235	9573	254		

■ New product

A	Life-changing design choices	2
B	The heating system	3
C	The technical team	4
D	Tiemme Technical Service	5
E	Tiemme LAB	6
F	Tiemme BIM	7

80% of the annual energy we consume in our homes is linked to the production of hot water for heating and domestic use and energy spent for cooling rooms in the summer season. This percentage may increase or decrease according to the climate zone of the user and their personal choices, which determine, as way of example, how long the plants should be switched on, the desired temperature and the type of plant installed.

Despite some parameters linked to the local management, however, something is sure and certain: an adequate design, an efficient regulation and a correct maintenance allow to significantly reduce the energy consumption and consequently the operating costs.

The buildings or urban places of the future will be designed and built according to principles such as focusing on health and well-being, the environment and energy. The building industry must necessarily be oriented toward the realization of concepts linked to a sustainable design, that is, a design attentive to the satisfaction of every man's needs, with the priority of a reduced energy consumption in order not to preclude future generations from satisfying their own needs.

The home environment is increasingly seen as an «energy and raw material bank», the concept of «smart home» is by definition an intelligent environment, using an integrated system to improve comfort, safety and consumption of the people living in it. The home is therefore the place of the evolution of living in respect of the available resources and the users' well-being. The knowledge of the most innovative methodologies and techniques becomes the fundamental tool for guiding and applying design choices to the construction phase. Modern buildings must offer, in addition to continuity of operation, simplicity of maintenance and low running costs; for this reason, also heating systems must be characterized by high safety, reliability and total compliance with legislative and regulatory requirements.

the basic tool for guiding and applying design choices to the construction phase. Modern buildings must offer, in addition to continuity of operation, simplicity of maintenance and low running costs; for this reason, also heating systems must be characterized by high safety, reliability and total compliance with legislative and regulatory requirements.



DEFINITION

The heating system is a technological system used to heat or cool the environment.

Heating systems shall include:

- All plants for the environmental heating, for the environmental heating plus the production of domestic hot water or also for the production of domestic hot water alone if serving several users (plants equipped with boilers, heat pumps, fan-coils, heaters, radiators, etc.);
- All summer cooling systems (systems equipped with heat pumps for summer air conditioning, fan-coils, etc.).

The heating systems are:

- Heating systems equipped with heat generators running on gas, diesel, biomass, electricity, other (such as boilers, air conditioners, heat pumps);
- Stoves, fireplaces, fixed and localized radiant-energy heating appliances are considered as heating systems when the sum of the powers to the hearth (i.e. there must be a flame) of such units for each property is greater than or equal to 5 kW;
- Summer air-conditioning systems;
- Plants for the exclusive production of domestic hot water for a plurality of users or in any case not intended to serve individual residential or similar properties. This category includes, for example, applications for gyms or sports centers; centralized production of domestic hot water for condos and high-rises;
- Plants powered by district heating and/or co-generative systems and appliances.

However, heating systems do not include:

- Individual water heaters;
- Systems for the exclusive production of domestic hot water if they serve an individual property;
- Mobile heating or cooling appliances, i.e. not installed permanently on walls or ceilings, nor window air conditioners, even if they are fixed onto the wall or window.

ENERGY SYSTEMS

the air conditioning system in a building consists of 4 basic energy systems:

- **generation system;**
- **distribution system;**
- **emission system;**
- **adjustment system.**

The overall efficiency (η_g) depends on the efficiency of the single energy system:

- **production efficiency η_p ;**
- **distribution efficiency η_d ;**
- **emission efficiency η_e ;**
- **adjustment efficiency η_r .**

$$\eta_g = \eta_p * \eta_d * \eta_e * \eta_r$$

The central heating is the heart of the plant, from here the water is heated and cooled to be distributed to the emission terminals and ensure excellent comfort in every room. The efficiency of the plant starts from the central heating which, if installed according to the rule of the art and managed by an efficient regulation can drastically reduce the energy costs. A good system design and creation is necessary but not enough to save energy. The maintenance during the years of the technical room also plays an important role. An efficient and well-maintained system over the years ensures safety and pollutes less for the benefit of our health and the quality of the environment we live in.

Regulations both at European and national level, being constantly evolving, have as their priority the adoption of increasingly efficient technologies aimed at global energy saving and systems' supervision, both in operating and control and maintenance conditions.

In view of these premises, Tiemme is committed to offering a complete range of components to ensure an excellent control and energy efficiency of the heating system.

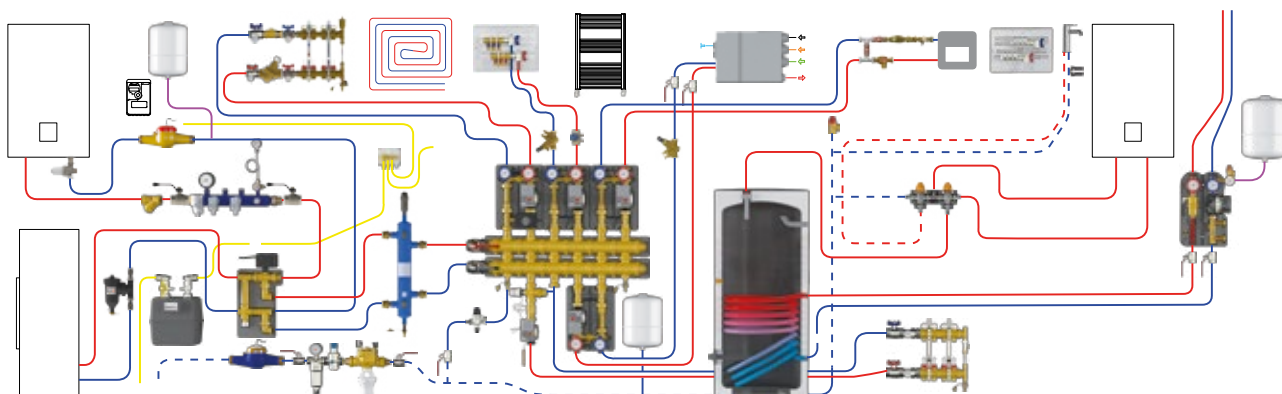

Tiemme strongly believes that the a support service for the design phase is critical for installers and professionals. The company also includes a department solely devoted to the design and quote of radiant systems, metering systems, and thermal center. Highly qualified and experienced operators in the field of design listen understand client requirements and guide him to choose the best solution that fits their needs. The system division guarantees adequate support even on any needs that might arise on the site, from controlling the correct functioning to initial system configuration and operation phases. The team organizes work so as to reduce response time to a minimum. The services is offered for free but it is greatly valuable and develops about 5000 projects per year.

Tiemme relies on a long list of specialists working with a wide range of corporate instruments to provide tailored counseling in any phase.



Tiemme Technical Service (TTS), is a service guaranteed by Tiemme and provided thanks to many professional partners collaborating with us to create a competent and available support network.

TTS can satisfy any request concerning Tiemme's sector of operations, from single product installation to operation, testing, maintenance, and repairs of simple and complex systems.

For further information on this service, write to the following e-mail address: sistemi@tiemme.com.

TIEMME, EXCLUSIVE CUSTOMER CARE

You can find precious information for your job or activity, in "MyTiemme" reserved area of our website. Tiemme has made its catalogs available online for you to read or download at any time. You will also find our technical catalogs, brochures, specifications, certifications, declarations of performance and compliance. You can access them from the page including the details of your desired item.

The platform is supported by any device.

www.tiemme.com

DID NOT FIND WHAT YOU WERE LOOKING FOR?

- Customer service: customerservice@tiemme.com
- After-sales service: service@tiemme.com
- Get a quote: sistemi@tiemme.com
- Tiemme S.p.A: info@tiemme.com
- T +39 030 2142211 - F +39 030 2142206





The training center **Tiemme LAB**, is Tiemme's pride and joy. This important driver of innovation opened in 2012 and unveils for professionals operating in the sector Tiemme's wide range of solutions and an up-to-date selection of new products and technology. Training courses are regularly scheduled to enrich the expertise of professionals operating in the plumbing and heating industry, installation technicians, designers, thermal technicians, architects, and students, who can attend high level courses structured by type of application or designing techniques.



WHAT IS BIM?

BIM stands for “Building Information Modeling”, a digital process that takes place over the entire life span of the building (from design to maintenance). It allows to interact with other agents involved in the production chain through a smart digital model, entering and updating our data, reporting our changes or detecting somebody else’s. The purpose is to create a more fluid communication process, avoiding data losses and with real-time updates.



TIEMME AND BIM

Tiemme always keeps up with new trends and decided to include its product in the BIM world, so as to provide designers with the best support for their everyday design operations.

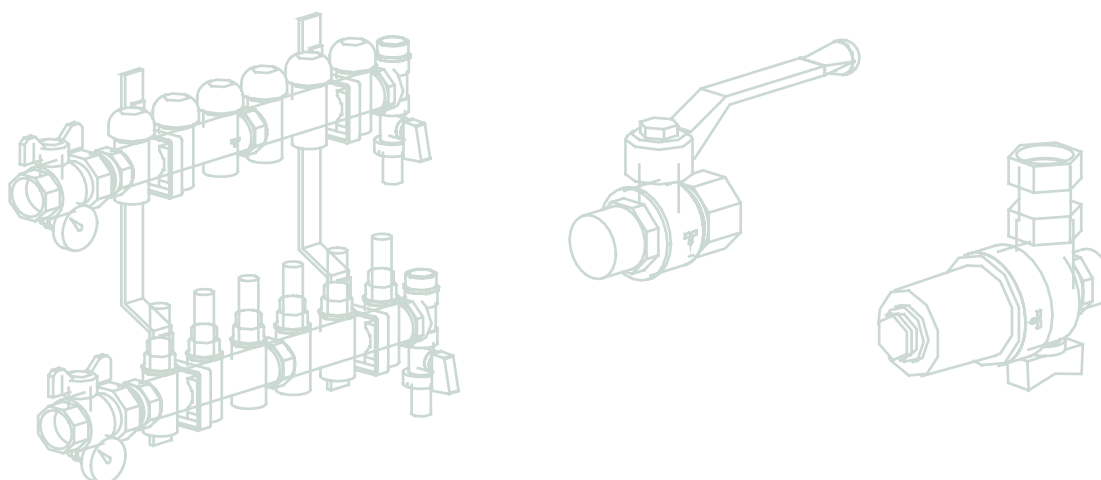
Hence, the company created an internal team with qualified personnel checking the quality and functioning of the products developed. If needed, our team can support the designer at any time, starting from the decisional phase, where they provide help to select the best product depending on client requirements, comply with sector-bound regulations, and identify the best approach, right through to actual interventions to solve any issue. BIM TIEMME models imply the use of verified products that match the actual object, thus granting access to the correct size, materials, certifications, and system sizing, in a single solution, without wasting any time looking for information.





01A Safety and control components

Safety valves		10
---------------	---	----

Safety unit		14
-------------	---	----

Thermometer and manometer		14
---------------------------	---	----

Pressure relief valves		15
------------------------	---	----

Fuel shut-off valve		16
---------------------	---	----

Temperature relief valve		17
--------------------------	---	----

INAIL instrument manifold		18
---------------------------	---	----

Pressure switches and safety thermostats		20
--	---	----

Safety valves for water heater		21
--------------------------------	--	----

Gas detection		21
---------------	---	----

01B Filling units		22
--------------------------	---	----

When the set pressure is reached the safety valves allow to open and thus drain the water from the system so as to prevent the pressure from reaching dangerous limits for the heat generator and for the components.

Tiemme safety valves comply with Directive 97/23/EC (PED - Pressure Equipment Directive) and are used for pressure control on heat generators in heating systems, on hot water build-ups in plumbing systems and water systems. Ordinary safety valves, according to the Italian regulations, may be applied to generators with a capacity of less than 35 kW.

OPERATION

The shutter (1), contrasted by a calibrated spring (2), rises when the set pressure is reached and opens the exhaust completely. The set pressure is selected according to the maximum possible pressure in the system. The diameter of the outlet union (3) is equal to or greater to facilitate the discharge of the required capacity. As the pressure decreases, the action is reversed, with the consequent re-closure of the valve within the prescribed tolerances.

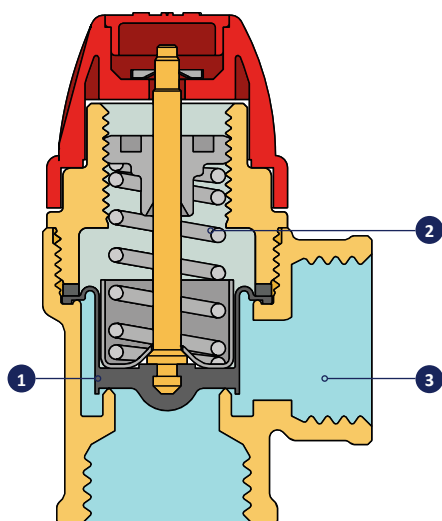

INSTALLATION

The safety valves can be installed both horizontally and vertically, respecting the direction indicated on the valve body. They must in no case be placed upside down to prevent their proper operation from being affected by the deposit of debris. Make sure to be advised by a qualified expert on the best safety valve after dimensional inspection of the system and in accordance with the regulations in force in your country. The exhaust circuit must also be properly sized and positioned to prevent damage to persons and/or things and avoid malfunctioning of the valve itself. In plumbing systems, the valve must be installed in the immediate vicinity of the hot water storage/boiler circuit and no shut-off device must be placed in it. In heating systems, the valve must be installed on the top of the heat generator or on the outlet line, ensuring a distance less than one meter. Again, no shut-off device must be placed in it.

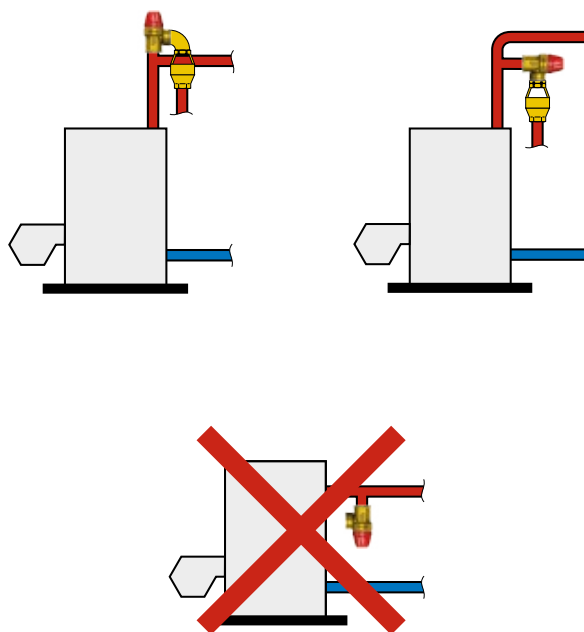

MAINTENANCE

The valve test must be carried out at least once a year by increasing the system pressure until it is discharged. Any impurities formed on the seat can be removed by means of regular purges.





1917 1927

Safety valve female connections

TECHNICAL SPECIFICATIONS

- Min operating temperature: -5°C
- Max operating temperature: 120°C
- Nominal pressure: PN10
- Body material: Brass CW617N
- Opening overpressure: 10%
- Connection threads: ISO 228 female

Code	Type	Calibration	Price €	Unit/Box
192 0013	1/2" x 1/2"	1.5 bar		1/40
192 0033	1/2" x 1/2"	1.8 bar		1/40
192 0025	1/2" x 1/2"	2 bar		1/40
192 0008	1/2" x 1/2"	2.5 bar		1/40
192 0001	1/2" x 1/2"	3 bar		1/40
192 0060	1/2" x 1/2"	3.5 bar		1/40
192 0010	1/2" x 1/2"	4 bar		1/40
192 0053	1/2" x 1/2"	5 bar		1/40
192 0006	1/2" x 1/2"	6 bar		1/40
192 0022	1/2" x 1/2"	7 bar		1/40
192 0035	1/2" x 1/2"	8 bar		1/40
192 0011	1/2" x 1/2"	9 bar		1/40
192 0018	1/2" x 1/2"	10 bar		1/40
192 0014	3/4" x 3/4"	1.5 bar		1/40
192 0027	3/4" x 3/4"	1.8 bar		1/40
192 0034	3/4" x 3/4"	2 bar		1/40
192 0012	3/4" x 3/4"	2.5 bar		1/40
192 0003	3/4" x 3/4"	3 bar		1/40
192 0054	3/4" x 3/4"	3.5 bar		1/40
192 0015	3/4" x 3/4"	4 bar		1/40
192 0071	3/4" x 3/4"	5 bar		1/40
192 0007	3/4" x 3/4"	6 bar		1/40
192 0036	3/4" x 3/4"	7 bar		1/40
192 0030	3/4" x 3/4"	8 bar		1/40
192 0043	3/4" x 3/4"	9 bar		1/40
192 0031	3/4" x 3/4"	10 bar		1/40
192 0072	1" x 1"	1.5 bar		1/25
192 0073	1" x 1"	1.8 bar		1/25
192 0074	1" x 1"	2 bar		1/25
192 0075	1" x 1"	2.5 bar		1/25
192 0004	1" x 1"	3 bar		1/25
192 0076	1" x 1"	3.5 bar		1/25

1917-1927 - Safety valve female connections

Code	Type	Calibration	Price €	Unit/Box
192 0023	1" x 1"	4 bar		1/25
192 0077	1" x 1"	5 bar		1/25
192 0009	1" x 1"	6 bar		1/25
192 0016	1" x 1"	7 bar		1/25
192 0026	1" x 1"	8 bar		1/25



1918 1928

Safety valve male-female connections

TECHNICAL SPECIFICATIONS

- Min operating temperature: -5°C
- Max operating temperature: 120°C
- Nominal pressure: PN10
- Body material: Brass CW617N
- Opening overpressure: 10%
- Connection threads: ISO 228 male-female

Code	Type	Calibration	Price €	Unit/Box
192 0052	1/2" x 1/2"	1.5 bar		1/40
192 0078	1/2" x 1/2"	1.8 bar		1/40
192 0045	1/2" x 1/2"	2 bar		1/40
192 0041	1/2" x 1/2"	2.5 bar		1/40
192 0002	1/2" x 1/2"	3 bar		1/40
192 0055	1/2" x 1/2"	3.5 bar		1/40
192 0020	1/2" x 1/2"	4 bar		1/40
192 0059	1/2" x 1/2"	5 bar		1/40
192 0005	1/2" x 1/2"	6 bar		1/40
192 0029	1/2" x 1/2"	7 bar		1/40
192 0037	1/2" x 1/2"	8 bar		1/40
192 0050	1/2" x 1/2"	9 bar		1/40
192 0038	1/2" x 1/2"	10 bar		1/40
192 0086	1" x 1"	1.5 bar		1/25
192 0087	1" x 1"	1.8 bar		1/25
192 0088	1" x 1"	2 bar		1/25
192 0089	1" x 1"	2.5 bar		1/25
192 0090	1" x 1"	3 bar		1/25
192 0091	1" x 1"	3.5 bar		1/25
192 0092	1" x 1"	4 bar		1/25
192 0093	1" x 1"	5 bar		1/25
192 0102	1" x 1"	6 bar		1/25
192 0019	1" x 1"	7 bar		1/25
192 0024	1" x 1"	8 bar		1/25



1917M 1927M

Safety valve female connections with increased outlet

TECHNICAL SPECIFICATIONS

- Min operating temperature: -5°C
- Max operating temperature: 120°C
- Nominal pressure: PN10
- Body material: Brass CW617N
- Opening overpressure: 10%
- Connection threads: ISO 7 female

INCREASED OUTLET

Code	Type	Calibration	Price €	Unit/Box
192 0066	1/2" x 3/4"	1.5 bar		1/40
192 0067	1/2" x 3/4"	1.8 bar		1/40
192 0048	1/2" x 3/4"	2 bar		1/40
192 0042	1/2" x 3/4"	2.5 bar		1/40
192 0040	1/2" x 3/4"	3 bar		1/40
192 0068	1/2" x 3/4"	3.5 bar		1/40
192 0069	1/2" x 3/4"	4 bar		1/40
192 0070	1/2" x 3/4"	5 bar		1/40
192 0039	1/2" x 3/4"	6 bar		1/40
192 0057	1/2" x 3/4"	7 bar		1/40
192 0096	1/2" x 3/4"	8 bar		1/40
192 0097	1/2" x 3/4"	9 bar		1/40
192 0098	1/2" x 3/4"	10 bar		1/40



1917MAN 1927MAN

Safety valve female connections with 1/4" pressure gauge connection

TECHNICAL SPECIFICATIONS

- Min operating temperature: -5°C
- Max operating temperature: 120°C
- Nominal pressure: PN10
- Body material: Brass CW617N
- Opening overpressure: 10%
- Connection threads: ISO 228 female

WITH PRESSURE GAUGE CONNECTION

Accessory: Manometer art. 2080POST see page 14

Code	Type	Calibration	Price €	Unit/Box
192 0061	1/2" x 1/2"	1.5 bar		1/40
192 0062	1/2" x 1/2"	1.8 bar		1/40
192 0063	1/2" x 1/2"	2 bar		1/40
192 0046	1/2" x 1/2"	2.5 bar		1/40
192 0028	1/2" x 1/2"	3 bar		1/40
192 0064	1/2" x 1/2"	3.5 bar		1/40
192 0044	1/2" x 1/2"	4 bar		1/40
192 0065	1/2" x 1/2"	5 bar		1/40
192 0058	1/2" x 1/2"	6 bar		1/40
192 0051	1/2" x 1/2"	7 bar		1/40
192 0094	1/2" x 1/2"	8 bar		1/40
192 0095	1/2" x 1/2"	9 bar		1/40
192 0056	1/2" x 1/2"	10 bar		1/40





1918MAN 1928MAN

Safety valve male-female connections with 1/4" pressure gauge connection

TECHNICAL SPECIFICATIONS

- Min operating temperature: -5°C
- Max operating temperature: 120°C
- Nominal pressure: PN10
- Body material: Brass CW617N
- Opening overpressure: 10%
- Connection threads: ISO 228 male-female

+ WITH PRESSURE GAUGE CONNECTION

i Accessory: Manometer art. 2080POST see page 14

Code	Type	Calibration	Price €	Unit/Box
192 0079	1/2" x 1/2"	1.5 bar		1/40
192 0080	1/2" x 1/2"	1.8 bar		1/40
192 0081	1/2" x 1/2"	2 bar		1/40
192 0082	1/2" x 1/2"	2.5 bar		1/40
192 0032	1/2" x 1/2"	3 bar		1/40
192 0083	1/2" x 1/2"	3.5 bar		1/40
192 0084	1/2" x 1/2"	4 bar		1/40
192 0085	1/2" x 1/2"	5 bar		1/40
192 0049	1/2" x 1/2"	6 bar		1/40
192 0047	1/2" x 1/2"	7 bar		1/40
192 0099	1/2" x 1/2"	8 bar		1/40
192 0100	1/2" x 1/2"	9 bar		1/40
192 0101	1/2" x 1/2"	10 bar		1/40



1916

Temperature and pressure safety valve male/copper pipe outlet connection

TECHNICAL SPECIFICATIONS

- Operating temperature: between 90 and 95°C.
- Operating pressure: 3-4-6-7 bar
- Nominal pressure PN 10
- Fluid: Water
- Body material: Brass CW617N
- Complies with European standard EN 1490 and Directive 97/23/EC (PED)

+ TEMPERATURE-PRESSURE CONTROL

Code	Type	Calibration	Price €	Unit/Box
192 0106	1/2" x 15	3 bar		1/10
192 0107	1/2" x 15	4 bar		1/10
192 0108	1/2" x 15	6 bar		1/10
192 0109	1/2" x 15	7 bar		1/10
192 0111	3/4" x 15	3 bar		1/10
192 0112	3/4" x 15	4 bar		1/10
192 0113	3/4" x 15	6 bar		1/10
192 0114	3/4" x 15	7 bar		1/10
192 0116	3/4" x 22	3 bar		1/10
192 0117	3/4" x 22	4 bar		1/10
192 0118	3/4" x 22	6 bar		1/10
192 0119	3/4" x 22	7 bar		1/10



3175CT
Safety unit with insulation for wood-fired boilers

Code	Type	Price €	Unit/Box
319 0010	1" - 1,5 bar		1/5
319 0009	1" - 3 bar		1/5



3175ISOL
Safety unit with insulation for wood-fired boilers

Code	Type	Price €	Unit/Box
319 0003	1" - 1,5 bar		1/5
319 0001	1" - 3 bar		1/5

VIDEO TUTORIALS



Safety unit with insulation for wood-fired boilers - Operating principle

01_A THERMOMETER AND MANOMETER



2080POST
Pressure gauge with rear union off center



Code	Type	Scale	Price €	Unit/Box
192 0021	1/4"	0 - 4 bar		1/40
192 0017	1/4"	0 - 10 bar		1/40

For safety valves with calibration up to 3 bar



2081
Thermometer manometer 0-120°C/0-6 bar

Code	Type	Price €	Unit/Box
208 0001	1/4" (1/2")		1/30



2080
Manometer radial connection Ø50

Code	Type	Scale	Price €	Unit/Box
318 0007	1/4"	0 - 6 bar		5/25
318 0025	1/4"	0 - 16 bar		5/25



Tiemme pressure relief valves are self-regulating valves allowing the system pressure to be kept constant within specified limits by discharging the amount of fluid set by adjusting the shutter position.

The force is applied directly by means of a spring (direct action). Once the pressure reference point has been defined, the pressure relief valve adjusts itself by increasing or decreasing the outflow section and consequently the discharge flow to maintain constant pressure in the system.

If the system pressure is lower than the reference pressure, the pressure relief valve closes automatically. The discharge side of the enclosure is ductable, therefore it is suitable for use with liquids, gases and vapors (group 1 if compatible). The pressure relief valve meets the essential safety requirements of the European Directive 97/23/EC (PED - Pressure Equipment Directive).

WARNING!

Do not use as pressure reducing/safety valves.

PRODUCT RANGE



19210M

Angled pressure relief valve with female connections, duct discharge, can be calibrated 0÷16 bar, with metal shutter

TECHNICAL SPECIFICATIONS

- Min operating temperature: 5°C
- Max operating temperature: 200°C
- Nominal pressure: PN16 (3/8" to 2")- PN10 (2"½ to 3")
- Body material: Brass CW617N
- Opening overpressure: 20%
- Connection threads: ISO 228 female

Code	Type	Price €	Unit/Box
196 0001	3/8"		12/48
196 0002	1/2"		10/40
196 0003	3/4"		7/28
196 0004	1"		4/16
196 0005	1"1/4		2/8
196 0006	1"1/2		1/4
196 0007	2"		1/4
196 0008	2"1/2		1/1
196 0009	3"		1/1



19210P

Angled pressure relief valve with female connections, duct discharge, can be calibrated 0÷16 bar, with PTFE shutter

TECHNICAL SPECIFICATIONS

- Min operating temperature: 5°C
- Max operating temperature: 180°C
- Nominal pressure: PN16 (3/8" to 2")- PN10 (2"½ to 3")
- Body material: Brass CW617N
- Opening overpressure: 20%
- Connection threads: ISO 228 female

Code	Type	Price €	Unit/Box
196 0037	3/8"		12/48
196 0038	1/2"		10/40
196 0039	3/4"		7/28
196 0040	1"		4/16
196 0041	1"1/4		2/8
196 0042	1"1/2		1/4
196 0043	2"		1/4
196 0044	2"1/2		1/1
196 0045	3"		1/1



19210G

Angled pressure relief valve with female connections, duct discharge, can be calibrated 0÷16 bar, with SBR shutter

TECHNICAL SPECIFICATIONS

- Min operating temperature: 5°C
- Max operating temperature: 70°C
- Nominal pressure: PN16 (3/8" to 2")- PN10 (2"½ to 3")
- Body material: Brass CW617N
- Opening overpressure: 20%
- Connection threads: ISO 228 female

Code	Type	Price €	Unit/Box
196 0019	3/8"		12/48
196 0020	1/2"		10/40
196 0021	3/4"		7/28
196 0022	1"		4/16
196 0023	1"1/4		2/8
196 0024	1"1/2		1/4
196 0025	2"		1/4
196 0026	2"1/2		1/1
196 0027	3"		1/1

The fuel shut-off valve, used in heating systems (central heating), intercepts the fuel flow to the burner to prevent the water temperature in the system delivery circuit from reaching the sensor calibration value.

- INAIL approved and calibrated (ex ISPESL)
- Complies with PED Directive 2014/68/EU, identification number CE0497
- Compliant with "R Collection" 2009 edition (Application technical specifications of Title II of Ministerial Order 1.12.75)

OPERATION

The device consists of two parts:

- the valve body which the liquid or gaseous fuel flows into.
- the control device equipped with a sensitive element (bulb).

The temperature-sensitive element, immersed in the heat carrier fluid, acts on the valve shutter when the calibration temperature is reached, intercepting the fuel flow to the burner.

MANUAL RESET: If the valve is triggered by the coolant temperature rising to the calibration point, it is necessary to wait until the coolant temperature drops by at least 10 ± 2 °C from the calibration value indicated on the label in order to manually reset the valve. Resetting occurs manually by operating a button.

FAIL-SAFE ACTION: The Tiemme valve allows the fuel flow to be shut off even in the event of failure of the sensitive element, or breakage of the capillary (fail-safe action).

In this case it is no longer possible to reset the valve, so a replacement is necessary.

INSTALLATION

The valve body must be installed on the fuel supply line, downstream of the regulating devices, with the arrow (indicated on the body of the device) facing the line. It may be installed both horizontally (with the reset knob facing upwards) and vertically.

It must never be placed upside down (with the reset knob facing down). The valve sensor must be installed on the top of the generator, or on the supply line within 1 mt, upstream of any shut-off device.

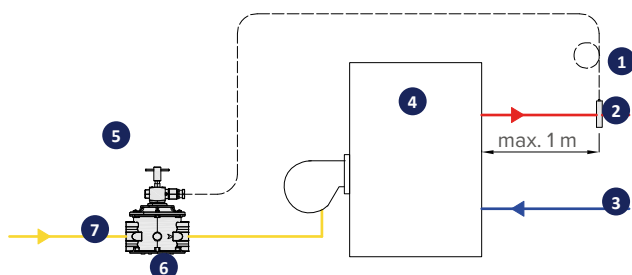

1. Sensor
2. Supply (hot water)
3. Return (cold water)
4. Generator
5. Valve body
6. Art. 1725OT – 1725AL
7. Fuel supply line

PRODUCT RANGE



1725OT

Fail-safe action fuel shut-off valve with manual reset, calibrated and INAIL certified, brass body

TECHNICAL SPECIFICATIONS

- Room temperature: $-15 \div +70$ °C
- Max operating pressure: 1 bar
- Well fitting: G 1/2"
- Capillary length: 5 m
- Use: I, II and III family gas (city gas, methane, LPG), diesel and fuel oil
- Connection threads: female ISO 7/1 (EN 10226)

i Version with capillary length 10 m available on request

Code	Type	Price €	Unit/Box
172 0001	1/2" - 98°C - 5m		1/1
172 0004	1/2" - 110°C - 5m		1/1
172 0002	3/4" - 98°C - 5m		1/1
172 0005	3/4" - 110°C - 5m		1/1
172 0003	1" - 98°C - 5m		1/1
172 0006	1" - 110°C - 5m		1/1



1725AL

Fail-safe action fuel shut-off valve with manual reset, calibrated and INAIL certified, aluminum body

TECHNICAL SPECIFICATIONS

- Room temperature: $-15 \div +70$ °C
- Max operating pressure: 1 bar
- Well fitting: G 1/2"
- Capillary length: 5 m
- Use: I, II and III family gas (city gas, methane, LPG), diesel and fuel oil
- Connection threads: female ISO 7/1 (EN 10226)

i Version with capillary length 10 m available on request

Code	Type	Price €	Unit/Box
172 0013	1" 1/4 - 98°C - 5m		1/1
172 0016	1" 1/4 - 110°C - 5m		1/1
172 0014	1" 1/2 - 98°C - 5m		1/1
172 0017	1" 1/2 - 110°C - 5m		1/1
172 0015	2" - 98°C - 5m		1/1
172 0018	2" - 110°C - 5m		1/1



The temperature relief valve, used in heating systems (central heating), allows the water to be drained when the set temperature is reached, preventing overheating.

- INAIL approved and calibrated (ex ISPESL)
- Complies with PED Directive 2014/68/EU, identification number CE1115.
- Compliant with "R Collection" 2009 edition (Application technical specifications of Title II of Ministerial Order 1.12.75)
- Complies with LVD 2014/35/UE, EMC 2014/30/UE.

OPERATION

The temperature-sensitive element, immersed in the heating carrier fluid, acts on the valve shutter when the set temperature is reached, discharging the water from the system.

The movement of the shutter controls an electrical diverter which can provide a contact that can be used, for example, to interrupt the fuel supply to the burner.

Once the microswitch has been activated, it needs to be manually reset by acting on the appropriate button on the cap.

When the re-set temperature is reached, the valve closes automatically.

The valve allows the discharge to be opened even in the event of a thermal-sensitive element failure (fail-safe action).

INSTALLATION

The temperature relief valves must be connected to the generator outlet pipe, upstream of any shut-off device, with the sensitive element immersed in the hot water stream at the outlet as close as possible to the generator (within 1 m).

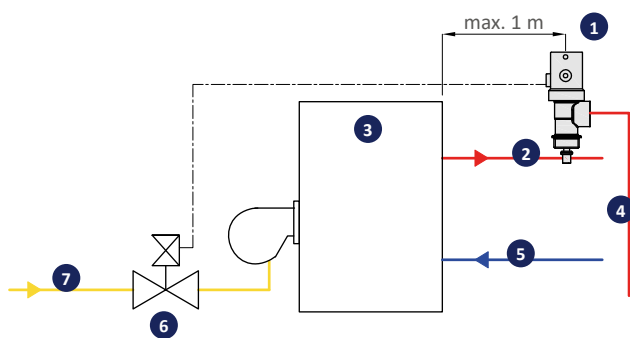

1. Art. 1925
2. Supply (hot water)
3. Generator
4. Duct discharge
5. Return (cold water)
6. Solenoid valve
7. Fuel supply line

PRODUCT RANGE



1925

Temperature relief valve with fail-safe action, manual reset and optical signal, calibrated and INAIL certified.

TECHNICAL SPECIFICATIONS

- Calibration temperature: 95°C
- Discharge temperature: 96°C
- Closing temperature: 92°C
- Cable length: 1.2 m
- Thermosensitive element: wax-type
- Microswitch: 230V-50Hz, with manual reset button
- Optical signal: red valve opening signal

Code	Type	Price €	Unit/Box
192 0152	1" 1/4 x 1" 1/4		1/40
192 0153	1" 1/2 x 1" 1/2		1/40

01_A INAIL INSTRUMENT MANIFOLD

The instrument manifold compactly combines all INAIL components and accessories listed in the “R Collection” as mandatory instruments for the safety, protection and control of central heating systems above 35kW.

The devices the manifold is made of are PED certified or INAIL compliant.

INSTALLATION

The instrument manifold must be installed on the supply line. The device may be installed both horizontally and vertically.



Horizontally



Vertically

INSTALLATION SAMPLE

Application example of a central heating system supplied with a cascade boiler with power >35kW and an INAIL instrument manifold applied in horizontal position on the system supply line.

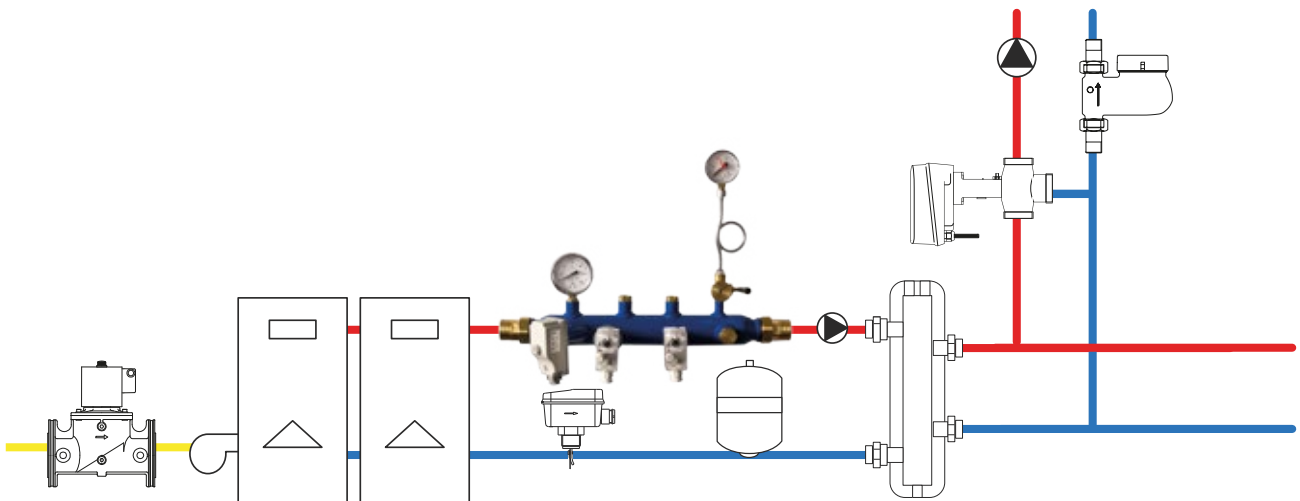



7169
INAIL instrument manifold

TECHNICAL SPECIFICATIONS

- Manifold body: S195T painted steel
- Main connections: threaded with 1"1/4, 1"1/2, 2" unions and flanged (PN 16) DN50, DN65 and DN80
- Fluid used: water and glycol solution (maximum percentage 30%)
- Operating Pmax: 10 bar
- Temperature range: 0 ÷ 110 °C

Code	Type	Price €	Unit/Box
321 0001	1"1/4		1/1
321 0002	1"1/2		1/1
321 0003	2"		1/1
321 0004	DN50		1/1
321 0005	DN65		1/1
321 0006	DN80		1/1

7169 CONFIGURATION

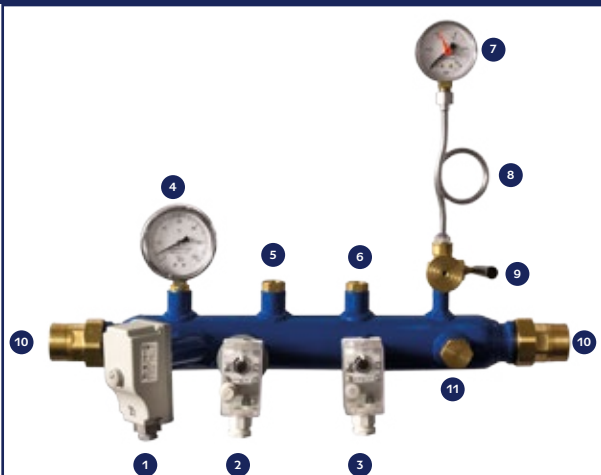

1. Immersion thermostat (PED certified)
2. Manual reset safety pressure switch (PED certified)
3. Manual reset safety minimum pressure switch (PED certified)
4. Thermometer (INAIL compliant)
5. Well fuel shut-off valve well
6. Control well
7. Pressure gauge (INAIL compliant)
8. Pressure gauge coil siphon
9. Pressure gauge cock
10. Fittings
11. Connection pre-set for INAIL safety valve



1923
Pressure gauge cock, male-female connector with stuffing box and bleeder bore. Thermoplastic handle

Code	Type	Price €	Unit/Box
199 0007	1/4"		15/60
199 0008	3/8"		10/40
199 0009	1/2"		5/20



1923FL
Female-male gauge cock with stuffing box, flange and flange plug. Thermoplastic handle

Code	Type	Price €	Unit/Box
199 0001	1/4"		15/60
199 0002	3/8"		10/40
199 0003	1/2"		5/20



1924
Fixed-male pressure gauge coil siphon, swivel cap and copper pipe Ø 8 mm

Code	Type	Price €	Unit/Box
178 0001	1/4"		10/40
178 0002	3/8"		10/40
178 0003	1/2"		10/40



2074MIN
Manual reset minimum pressure switch, IP44

Code	Type	Price €	Unit/Box
075 0069	0.5 ÷ 2.5 Bar		1/20



2074MAX
Manual reset maximum pressure switch, IP44

Code	Type	Price €	Unit/Box
075 0068	2 ÷ 5.5 Bar		1/20



2079
Pressure switches for booster-sets and plumbing installations

Code	Type	Price €	Unit/Box
075 0022	1 - 5 Bar		1/50
075 0039	3 - 12 Bar		1/15



2075
Adjustable contact thermostat

TECHNICAL SPECIFICATIONS

- Adjustment range: 0-90°C
- Outlet: Voltage-free changeover contacts 16(4) TO/250 Vac-6(1) TO/400 Vac
- Protection rating: IP40
- Differential: 6 ± 2°C
- Retaining spring included

Code	Type	Price €	Unit/Box
957 0001	0/90°C		1/20



2076
Adjustable immersion thermostat

TECHNICAL SPECIFICATIONS

- Includes sheath with 1/2" thread
- Adjustment range: 0-90°C
- Outlet: Voltage-free changeover contacts 16(4) TO/250 Vac-6(1) TO/400 Vac
- Protection rating: IP40
- Differential: 6 ± 2°C

Code	Type	Price €	Unit/Box
957 0003	0/90°C - 1/2"		1/10



2077
Immersion thermostat with fixed calibration

TECHNICAL SPECIFICATIONS

- Includes sheath with 1/2" thread
- Operating temperature: 96 ± 3°C
- Outlet: 16(2,5) A/250 Vac cut-off contact
- Protection rating: IP40
- Differential: 4 ± 2°C
- Manual reset

Code	Type	Price €	Unit/Box
957 0016	96°C - 1/2"		1/10



2078
Double-action immersion thermostat: fixed setting and calibration

TECHNICAL SPECIFICATIONS

- Includes sheath with 1/2" thread
- Adjustment range: 30-90°C
- Operating temperature: 96 ± 3°C
- Setting outlet: voltage-free changeover contacts 16(4) TO/250 Vac
- Fixed calibration outlet: 16(2,5) A/250 Vac cut-off contact
- Protection rating: IP40
- Differential: 4 ± 2°C
- Manual reset

Code	Type	Price €	Unit/Box
957 0010	30/90°C - 96°C 1/2"		1/5



01A SAFETY VALVES FOR WATER HEATER



1919
Safety valves for water heater

TECHNICAL SPECIFICATIONS

- Max operating temperature: 120°C
- Nominal pressure: PN10
- Body material: Brass CW617N
- Connecting threads: ISO 228 male-female

Code	Type	Calibration	Price €	Unit/Box
193 0002	1/2"	8.5 bar		5/50



1929
Safety valves with handle for water heater

TECHNICAL SPECIFICATIONS

- Max operating temperature: 120°C
- Nominal pressure: PN10
- Body material: Brass CW617N
- Connecting threads: ISO 228 male-female

Code	Type	Calibration	Price €	Unit/Box
193 0001	1/2"	8.5 bar		5/50

01A GAS DETECTION



2082R
CNG/LPG detector

Code	Type	Price €	Unit/Box
207 0005	CNG-230 Vac		1/10
207 0008	LPG-230 Vac		1/10



2082KIT
CNG detector kit manual reset normally open solenoid valve

Code	Type	Price €	Unit/Box
207 0003	1/2" - 230 Vac		1/4
207 0004	3/4" - 230 Vac		1/4



2082E
Manual reset normally open solenoid valve for CNG

Code	Type	Price €	Unit/Box
207 0001	1/2" - 230 Vac		1/10
207 0002	3/4" - 230 Vac		1/10
207 0007	1" - 230 Vac		1/10

Tiemme automatic filling unit art. 3160K is a device consisting of a pressure reducing valve with a compensated seat (1), inlet filter (2), shut-off cock (3), and a check valve (4), which is installed on the water supply pipe in heating systems, **it has the main function to keep the system pressure stable, at a set value, by automatically restoring any missing water.** A correct installation of a filling unit provides for the protection of the device by means of a filter with a suitable filter mesh, a check valve or disconnecter depending on the dangerousness of the water and the possibility of intercepting it through ball valves in order to carry out the proper maintenance operations. After installation, during filling or refilling, the power supply will stop when the calibration pressure is reached.

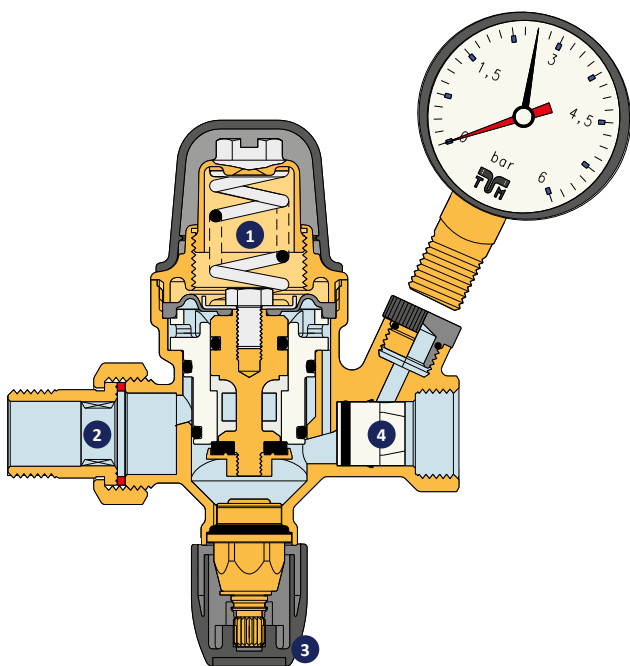

OPERATION

The fluid coming from the aqueduct enters the filling unit art. 3160K and loads up the system until the set pressure is reached.

When the system is under pressure, the actuator closes and does not allow fluid to flow, the check valve prevents a backflow into the duct.

The filling unit automatically reintegrates the water into the system if the pressure drops below the value until the set pressure is restored.

INSTALLATION

The installation of the filling unit art. 3160K can be carried out on both vertical and horizontal pipes.

MAINTENANCE

To clean and check or replace the inner cartridge, shut off the unit with an upstream shut-off valve, adjust the calibration pressure to a minimum, remove the upper screw, being careful with the spring and ring that may come out, close the shut-off cock to the end of its stroke so as to remove the cartridge, to replace or clean it; pull out the filter for cleaning/replacement, open the shut-off tap completely and reassemble the parts. Recalibrate the unit to the set calibration pressure.

PRODUCT RANGE



3160K
Automatic filling unit

TECHNICAL SPECIFICATIONS

- Adjustment range: 1-6 bar (Factory setting 1.5 bar)
- Max. Inlet pressure: 16 bar
- Max operating temperature: 65°C
- Body material: Chrome plated brass CW617N
- Inlet: 1/2" M ISO 228
- Outlet: 1/2" (1/228")
- Pressure gauge: 1/4" F
- Supplied with pressure gauge

Code	Type	Price €	Unit/Box
317 0001	1/2"		1/10





3161

Automatic filling unit with double shut-off and non-return valve for closed circuit heating systems

TECHNICAL SPECIFICATIONS

- Adjustment range: 1-6 bar (Factory setting 1.5 bar)
- Max. Inlet pressure: 16 bar
- Max operating temperature: 65°C
- Body material: Brass CW617N
- Pressure gauge: 1/4" F
- Supplied with pressure gauge

Code	Type	Price €	Unit/Box
317 0007	1/2"		1/8
317 0008	3/4"		1/8

ACCESSORIES AND SPARE PARTS



3180C

Spare cartridge for pressure reducing valve 3180 and filling unit 3160K-3161

Code	Type	Price €	Unit/Box
318 0053	3180/ 3160K/3161		1/40



3170

Antifreeze filling unit

TECHNICAL SPECIFICATIONS

- Min operating temperature: -20°C
- Max operating temperature: +100°C
- Max operating pressure: 10 bar
- Body material: Brass CW617N
- Main line connections: 1" M ISO 228
- Anti-freeze connectors: 3/4" M ISO 228
- Includes filter with 350 µm mesh
- Supplied with polystyrene foam (EPS) insulation

Code	Type	Price €	Unit/Box
317 0002	1"		1/2

3170

OPERATION

NORMAL OPERATION

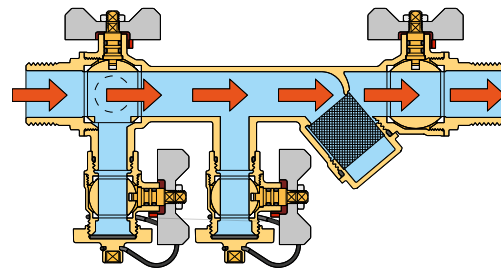

CHARGING OPERATION

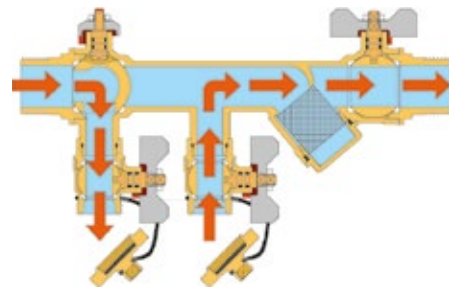

01_B FILLING UNITS

WITH DISCONNECTOR

The filling unit art. 3163 is used to automatically fill and refill water in the closed-circuit heating system, allowing the pressure in the circuit to be regulated.

A filling unit is particularly useful for compensating the pressure drops due to the release of air from the circuit, which takes place through the air-release valves and deaerators.

Installed on the water supply pipe, it fills/refills until the desired pressure is reached (Pressure setting).

The filling unit is equipped with a BA-type disconnecter to prevent any flow reversals. Can be used to protect the water mains against the risk of contamination from water up to category 4 (in accordance with EN 1717).

For further details, please refer to Section 7A "Anti-pollution devices - introduction" of this catalog.

PRODUCT RANGE



3163

Compact automatic filling unit with BA-type disconnecter and insulation

TECHNICAL SPECIFICATIONS

- Adjustment range: 1.5 - 5.5 bar (Factory setting 1.5 bar)
- Max. Inlet pressure: 10 bar
- Max operating temperature: 30 (inlet) °C/ 65 (outlet) °C
- Body material: CW617N brass
- Connection threads: male ISO 7/1 (EN 10226)
- BA-type disconnecter in accordance with EN 1717

Code	Type	Price €	Unit/Box
317 0010	3/4"		1/4

COMPONENT DESCRIPTION



1. Adjustable pressure reducing valve.
2. Circuit pressure setting knob.
3. Backflow prevention device (BA-type according to EN 1717)
4. Straight tundish
5. Pair of shut-off valves.
6. Patented double pressure gauge.
7. Measuring plugs.
8. Insulation shell.



The water filling and treatment unit art. 3164 is used to automatically fill and refill the water in the closed-circuit heating system, allowing the regulation of the pressure in the circuit, as well as the water treatment of the system.

Installed on the water supply pipe, it fills/refills until the desired pressure is reached (Pressure setting).

The filling unit is equipped with a BA-type disconnector to prevent any flow reversals. Can be used to protect the water mains against the risk of contamination from water up to category 4 (in accordance with EN 1717).

For further details, please refer to Section 7A "Anti-pollution devices - introduction" of this catalog.

In addition, it allows the water treatment of the heating system to be carried out, in accordance with the regulations in force.

Depending on the type of cartridge that is combined with the unit, it is possible to carry out the chemical-physical softening or demineralization treatment:



- **SOFTENING:** The softened water is poor in calcium and magnesium ions, the main ones responsible for incrustations (cartridge to be matched art. 3164CA).
- **DEMINERALIZATION:** Demineralized water (or deionized water) is water which the salt component was extracted from. It is characterized by its low electrical conductivity. It is ideal to prevent corrosion and lime deposits inside the circuit (cartridge art. 3164CD).

Installation takes a few simple steps and once the cartridge has run out, simply fill it with replacement granulates, without waste.

COMPONENT DESCRIPTION



1. Adjustable pressure reducing valve.
2. Circuit pressure setting knob.
3. Backflow prevention device (BA-type according to EN 1717)
4. Straight tundish
5. Pair of shut-off valves.
6. Electronic monitoring device.
7. Measuring plugs.
8. Adjusting the treatment percentage.
9. Demineralization/softening cartridge.
10. Insulation shell.



3164

Compact automatic water filling and treatment unit with BA-type disconnecter and insulation

TECHNICAL SPECIFICATIONS

- Adjustment range: 1.5 - 5.5 bar (Factory setting 1.5 bar)
- Max. Inlet pressure: 10 bar
- Max operating temperature: 30 (inlet) °C/ 65 (outlet) °C
- Body material: CW617N brass
- Connection threads: male ISO 7/1 (EN 10226)
- BA-type disconnecter in accordance with EN 1717

Code	Type	Price €	Unit/Box
317 0012	1/2"		1/1



3164CA

Water softener cartridge, including resin

Code	Type	Price €	Unit/Box
317 0014	for art. 3164		1/1



3164CD

Water demineralization cartridge, including resin

Code	Type	Price €	Unit/Box
317 0016	for art. 3164		1/1



3164RA

Resin refill cartridge for water softening

Code	Type	Price €	Unit/Box
317 0018	for art. 3164CA		1/1



3164RD

Resin refill cartridge for water softening

Code	Type	Price €	Unit/Box
317 0020	for art. 3164CD		1/1





3163CA
Disconnecter unit cartridge

Code	Type	Price €	Unit/Box
317 0026	for art. 3163 - 3164		1/1



3163CC
Wrench for cartridge removal
disconnecter unit

Code	Type	Price €	Unit/Box
317 0022	for art. 3163 - 3164		1/50



3163CR
Wrench for pressure reducing
valve removal and disconnecter
unit cover cap

Code	Type	Price €	Unit/Box
317 0024	for art. 3163 - 3164		1/50

02 HYDRAULIC SEPARATORS, DISTRIBUTION MANIFOLDS AND PUMPING STATIONS FOR CENTRAL HEATING SYSTEM

02A Introduction

Hydraulic units for central heating system	30
--	----

02B Hydraulic separators

Hydraulic separators - introduction	31
-------------------------------------	----

Steel hydraulic separators	 32
----------------------------	--

Brass hydraulic separators	 35
----------------------------	--

02C Manifolds for central heating system

Steel manifolds	 37
-----------------	--

Modular brass manifolds	 38
-------------------------	--

02D Control and pumping stations

DN25 Hydraulic power units	 47
----------------------------	--

DN32 Hydraulic power units	 52
----------------------------	--

Accessories	 54
-------------	--

A good solution to control and distribute fluid in the system is to use specific hydraulic mixing units for boiler rooms, also called central heating system, with distribution manifolds.

This chapter describes a full range of solutions for fluid management in a central heating system:

- Steel and brass hydraulic separators to separate the primary generating circuit from the secondary one.
- Steel and brass manifolds for central heating system to connect units to the generator;
- Hydraulic pumping, fixed point mixing, and modulating mixing stations

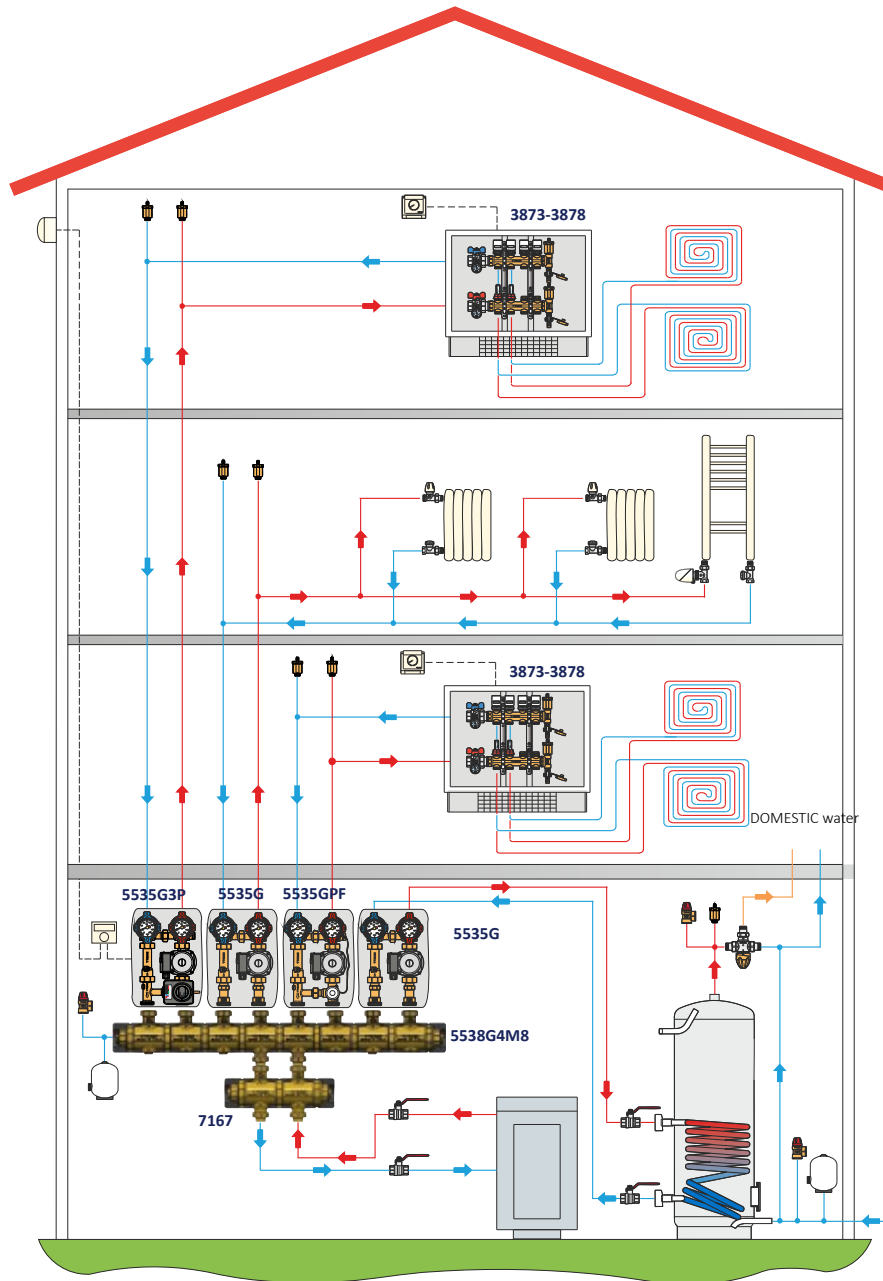

VIDEO TUTORIAL



Pumping stations



02_B HYDRAULIC SEPARATORS - INTRODUCTION

The hydraulic separator is used to make the primary circuit (heat generator) totally independent from the secondary circuit (utilities), thus compensating for possible differences in the flow rate or for required pressure drop, and preventing installed series of circulating pumps to affect each other.

It can be employed in cooling and heating systems including at least a main circulating pump and one or more secondary distribution pumps.

The hydraulic separator consists of a container usually placed in a vertical position and characterized by high internal flow sections, thus showing reduced pressure drop. It has 4 side fittings, two top fittings and two bottom fittings, enabling connection of the primary and secondary circuits.

In the event that the flow rate of the primary and secondary circuits are identical (condition 2), the hydraulic separator does not serve any purpose, while if one of the two currents has a higher flow rate (conditions 1-3), the hydraulic separator directs a part of said flow rate to the other current, so as to balance the two flows.

In this way, interferences between pumps of various circuits can be avoided, thus improving fluid circulation and guaranteeing the proper functioning of each circuit at designed conditions.

Below there is a graphic representation of the three hydraulic balance conditions that can occur in the separator:

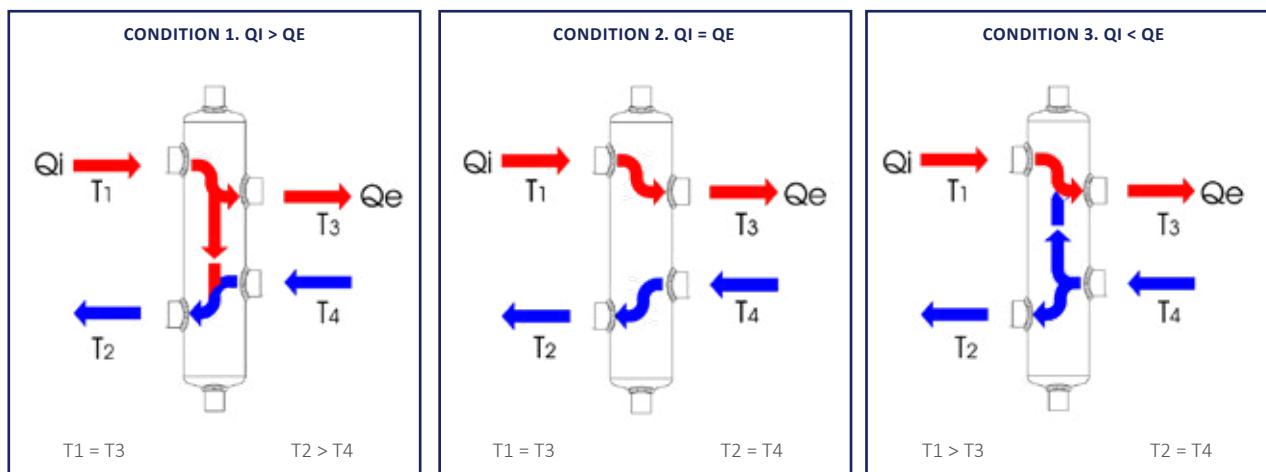

where:

Q_i = primary circuit flow rate

Q_e = secondary circuit flow rate

T_1 = Primary circuit flow temperature

T_2 = Primary circuit return temperature

T_3 = Secondary circuit flow temperature

T_4 = Secondary circuit return temperature

The design phase should take into account possible temperature variations that primary and secondary circuits can experience due to their mixing in the separator.

ADVANTAGES / STRENGTHS

- Separating function;
- Dirt separating function;
- Available with or without insulation shell;
- Professional deaerator (art. 1896);
- Can be turned in a magnetic version with 3144MAG accessory (art. 3165 - art. 3165ISOL).



3165
Threaded hydraulic separator

TECHNICAL SPECIFICATIONS

- Body material: Fe 360 steel painted with epoxy powder
- Max operating pressure: 10 bar
- Max operating temperature: 110°C

i Can be turned into a magnetic version with 3144MAG accessory.

Code	Type	Flow rate	Price €	Unit/Box
316 0006	1"	2.5 (m³/h)		1/1
316 0003	1"1/4	4.0 (m³/h)		1/1
316 0004	1"1/2	6.0 (m³/h)		1/1
316 0005	2"	9.0 (m³/h)		1/1



3165ISOL
Threaded insulated hydraulic separator

TECHNICAL SPECIFICATIONS

- Body material: Fe 360 steel painted with epoxy powder
- Insulation shell material: Foamed closed-cell PE-X
- Max operating pressure: 10 bar
- Max operating temperature: 100°C

i Can be turned into a magnetic version with 3144MAG accessory.

Code	Type	Flow rate	Price €	Unit/Box
316 0001	1"	2.5 (m³/h)		1/1
316 0002	1"1/4	4.0 (m³/h)		1/1
316 0008	1"1/2	6.0 (m³/h)		1/1
316 0007	2"	9.0 (m³/h)		1/1



3167ISOL
Flanged insulated hydraulic separator

TECHNICAL SPECIFICATIONS

- Body material: Fe 360 steel
- Insulation shell material: PPE
- Max operating pressure: 10 bar
- Max operating temperature: 100°C

Code	Type	Flow rate	Price €	Unit/Box
316 0106	DN50	9 (m³/h)		1/1
316 0107	DN65	20 (m³/h)		1/1
316 0108	DN80	25 (m³/h)		1/1
316 0109	DN100	40 (m³/h)		1/1
316 0110	DN125	65 (m³/h)		1/1
316 0111	DN150	95 (m³/h)		1/1

With a base for floor support



ADVANTAGES / STRENGTHS

- Separating function
- Dirt separating function
- Magnetic function
- Available with or without insulation shell
- Professional deaerator (art. 1896);



3144

Threaded magnetic hydraulic separator



TECHNICAL SPECIFICATIONS

- Body material: Fe 360 steel painted with epoxy powder
- Max operating pressure: 10 bar
- Max operating temperature: 110°C

Code	Type	Flow rate	Price €	Unit/Box
314 0001	1"	2.5 (m³/h)		1/1
314 0002	1"1/4	4.0 (m³/h)		1/1
314 0003	1"1/2	6.0 (m³/h)		1/1
314 0004	2"	9.0 (m³/h)		1/1



3144ISOL

Threaded insulated magnetic hydraulic separator



TECHNICAL SPECIFICATIONS

- Body material: Fe 360 steel painted with epoxy powder
- Insulation shell material: Foamed closed-cell PE-X
- Max operating pressure: 10 bar
- Max operating temperature: 100°C

Code	Type	Flow rate	Price €	Unit/Box
314 0005	1"	2.5 (m³/h)		1/1
314 0006	1"1/4	4.0 (m³/h)		1/1
314 0007	1"1/2	6.0 (m³/h)		1/1
314 0008	2"	9.0 (m³/h)		1/1

ACCESSORIES AND SPARE PARTS



3144MAG

Well kit with magnet



Code	Type	Price €	Unit/Box
316 0105	1/2"		1/25

DESCRIPTION OF COMPONENTS

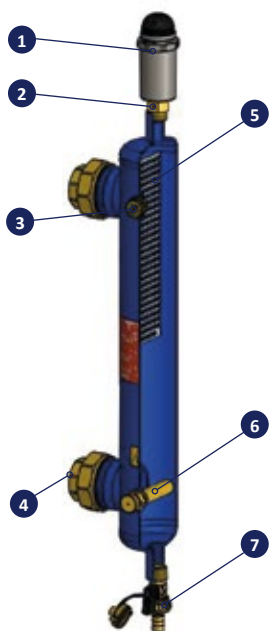

1. **Automatic air vent valve:** allows to eliminate air from the system
2. **Block and shut-off valve:** allows to maintain/replace the air vent valve without having to empty the system.
3. **Threaded G 1/2" fitting (with cap):**
(art. 3144 - 3144ISOL - 3165 - 3165ISOL)
allows to install a sensor-supporting well (art. 9561T) so as to monitor inflow temperature.
4. **3-Piece fittings with flat seat:**
(art. 3144 - 3144ISOL - 3165 - 3165ISOL)
facilitate the installation of the separator.
5. **Metal mesh:** favors the separation of dirt and directs air bubble towards the air vent valve placed at the top end of the separator.
6. **12,000 Gauss magnet:**
(art. 3144 - 3144ISOL)
placed in the bottom part of the device, it allows to improve filtering efficiency, by means of a magnetic field that captures ferrous impurities existing in the system.
7. **Loading/safety relief valve:** useful to load the system and eliminate sediments deposited in the separator.

DIMENSIONS

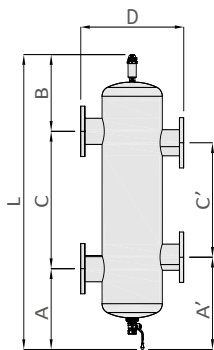
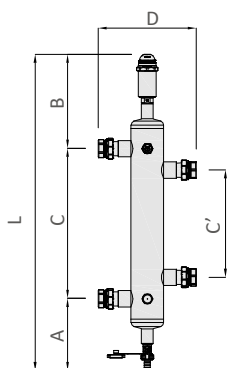

*With a base for floor support

Art.	Code	Size	A (mm)	A' (mm)	B (mm)	C (mm)	C' (mm)	D (mm)	L (mm)	Volume (liters)
3165	316 0006	G 1" F	165	215	220	350	250	229	735	1.9
	316 0003	G 1"1/4 F	165	215	220	350	250	269	735	2.65
	316 0004	G 1"1/2 F	190	240	245	500	400	320	935	6
	316 0005	G 2" F	190	240	245	650	550	338	1085	11.5
3165ISOL	316 0001	G 1" F	165	215	220	350	250	229	735	1.9
	316 0002	G 1"1/4 F	165	215	220	350	250	269	735	2.65
	316 0008	G 1"1/2 F	190	240	245	500	400	320	935	6
	316 0007	G 2" F	190	240	245	650	550	338	1085	11.5
3144	314 0001	G 1" F	165	215	220	350	250	229	735	1.9
	314 0002	G 1"1/4 F	165	215	220	350	250	269	735	2.65
	314 0003	G 1"1/2 F	190	240	245	500	400	320	935	6
	314 0004	G 2" F	190	240	245	650	550	338	1085	11.5
3144ISOL	314 0005	G 1" F	165	215	220	350	250	229	735	1.9
	314 0006	G 1"1/4 F	165	215	220	350	250	269	735	2.65
	314 0007	G 1"1/2 F	190	240	245	500	400	320	935	6
	314 0008	G 2" F	190	240	245	650	550	338	1085	11.5
3167ISOL	316 0106	DN50	340	365	320	320	270	350	980	11
	316 0107	DN65	350	375	335	400	350	400	1085	18
	316 0108	DN80	350	400	335	500	400	500	1185	34
	316 0109	DN100	350	400	335	600	500	520	1285	60
	*316 0110	DN125	575	650	335	750	600	520	1660	68
	*316 0111	DN150	580	655	340	1000	850	600	1920	140



ADVANTAGES / STRENGTHS

- Extremely compact;
- Can be complemented with Tiemme central system brass manifolds;
- Comes with insulation shell;
- Available with integrated shut-off valve (art. 7167).



7166
Hydraulic separators with insulation shell

TECHNICAL SPECIFICATIONS

- Max operating temperature: 100 °C
- Max operating pressure: 10 bar
- Body and components: Brass CW617N
- Outlets and fittings: 1" male thread
- Brackets: Galvanized steel
- Insulation shell: Cross-linked foam closed-cell polyethylene (PEX)
- Spacing: 125 mm

Code	Section	Flow rate	Price €	Unit/Box
316 0050	1"	2.5 (m³/h)		1/1



7167
Hydraulic separators with insulation shell and valves

TECHNICAL SPECIFICATIONS

- Max operating temperature: 100 °C
- Max operating pressure: 10 bar
- Body and components: Brass CW617N
- Outlets and fittings: 1" male thread
- Brackets: Galvanized steel
- Insulation shell: Cross-linked foam closed-cell polyethylene (PEX)
- Spacing: 125 mm

Code	Section	Flow rate	Price €	Unit/Box
316 0065	1"	2.5 (m³/h)		1/1

7166

DIMENSIONS

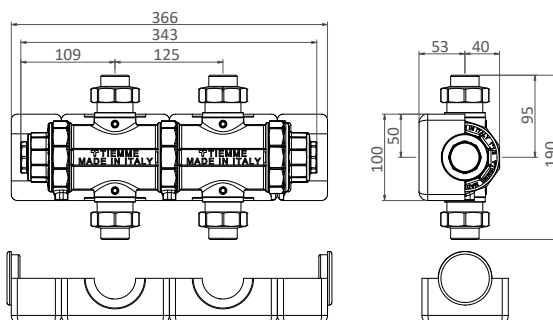

7167

DIMENSIONS

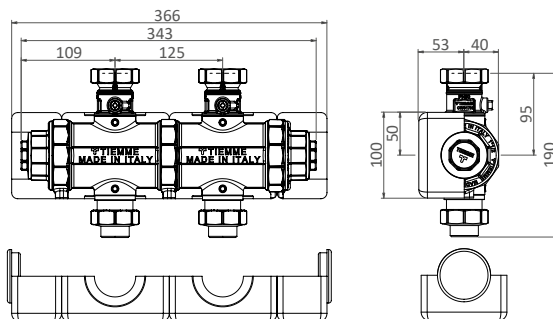

FUNCTIONING

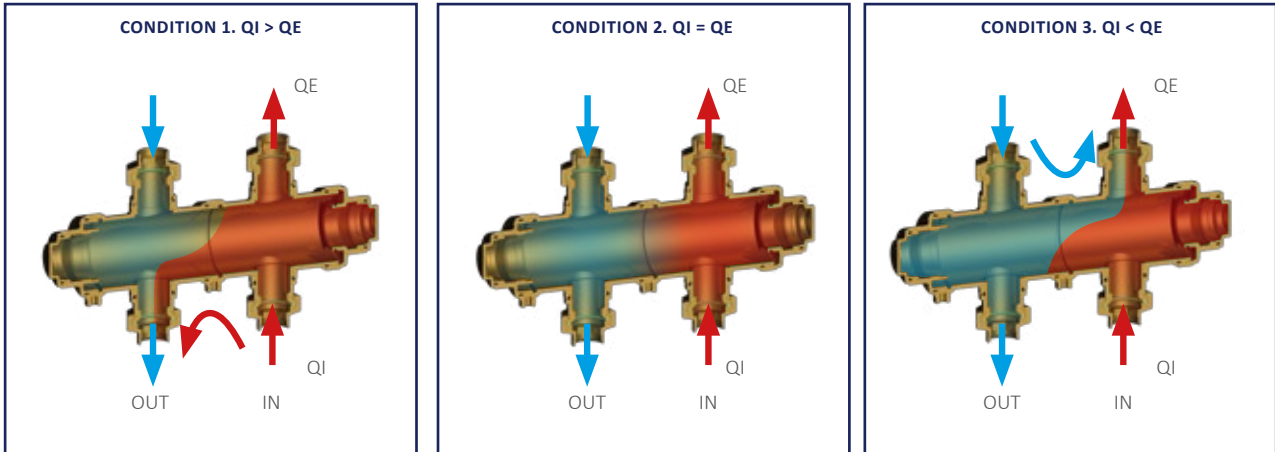

Q_I : primary circuit flow rate
 Q_E : secondary circuit flow rate

EXAMPLES OF ARRANGEMENTS

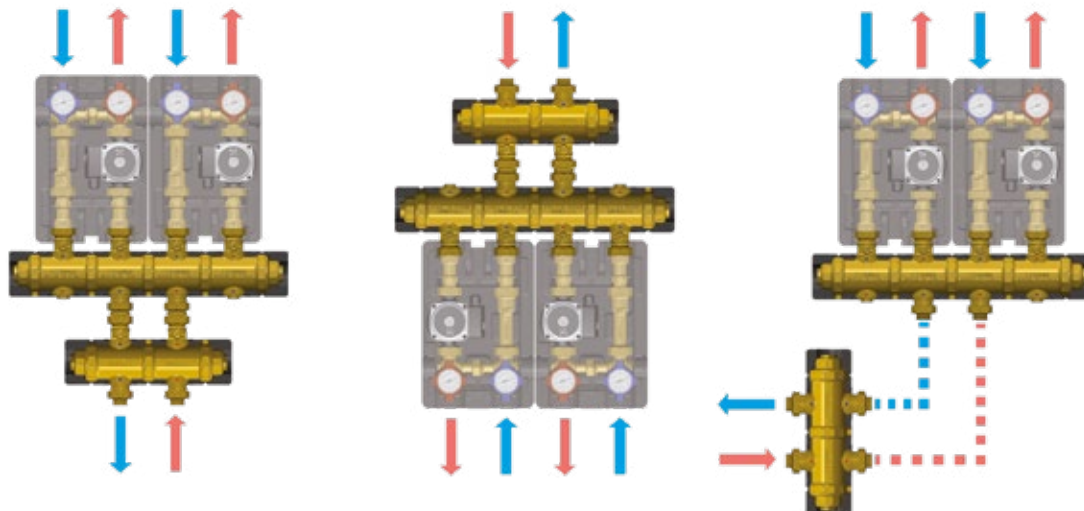

In order to meet any system need, Tiemme offers a series of steel compact manifolds to complement different pumping stations. Used in cooling and/or heating systems, they enable different thermal configurations in different environments, with only one heat generator or chiller, thus offering a compact solution that is easy to install. With insulation shell and available to feed up to 4 or 6 circuits, according to the model, they have 1"1/2 outlet fittings with flat seat and 125mm circuit spacing. Tiemme gives you the possibility of choosing a manifold with integrated hydraulic separator, art. 5539X, so as to offer easy installation and save domestic room. Tiemme steel compact manifolds, art. 5538X - 5540X - 5539X, come with pre-formed insulation shell, to guarantee perfect thermal insulation with both heating systems alone and cooling/heating systems.



5539X
Steel hydraulic separator/
manifold with insulation shell
and fixing brackets, 125 mm
circuit spacing, 1"1/2 fittings
with flat seat and cap



Code	Section	No. circuits	Flow rate	Price €	Unit/Box
557 0001	80 x 80	2	3.0 (m³/h)		1/1
557 0002	80 x 80	3	3.0 (m³/h)		1/1
557 0003	120 x 120	2	7.0 (m³/h)		1/1
557 0004	120 x 120	3	7.0 (m³/h)		1/1
557 0005	120 x 120	4	7.0 (m³/h)		1/1

5539X

OPERATION

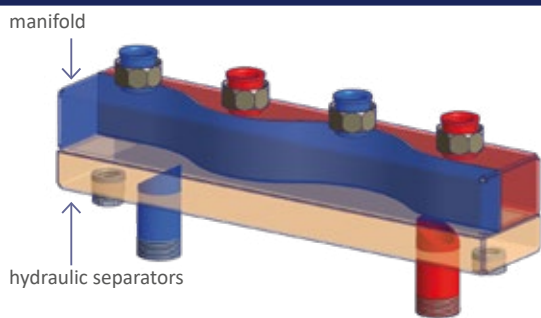

5538X 5540X

Steel manifold with insulation
shell and fixing brackets, 125
mm circuit spacing, 1"1/2
fittings with flat seat and cap



Code	Section	No. circuits	Flow rate	Price €	Unit/Box
557 0006	80 x 60	2	3.0 (m³/h)		1/1
557 0007	80 x 60	3	3.0 (m³/h)		1/1
557 0008	120 x 80	3	6.5 (m³/h)		1/1
557 0009	120 x 80	4	6.5 (m³/h)		1/1
557 0010	120 x 80	5	6.5 (m³/h)		1/1
557 0366	120 x 80	6	6.5 (m³/h)		1/1



5540X

Couple of floor soundproofing
and galvanized shelves

i 120x80 section accessory for manifold

Code	Type	Price €	Unit/Box
557 0011	h= 405-600 mm		1/1

Tiemme modular brass manifolds for central system are the result of a company's project aiming to create a unique and adaptable component that could be offered to their customers.

Central system manifolds are used in climate control systems that require different heating and cooling operations in different environments. The heat generator (boiler, closed fireplace, etc...) or heat pump represent the primary circuit with its dedicated circulating pump, while secondary circuits, with a dedicated circulating pump, are installed on the central system distribution manifold, according to required ways. This connection between primary and secondary circuits, at normal conditions create unexpected interferences, characterized by flow rate changes and secondary circuit head, as it is not possible to install a series of two or more circulating pumps. Therefore, a hydraulic separator should be placed between the primary and secondary circuits (with a distribution manifold) so that the two primary and secondary circuits will work independently without generating operating anomalies.

FUNCTIONING

Tiemme brass manifold is available in two arrangements: art. 5538G, for a 2.2 m³/h flow rate (up to 3 m³/h max) with a peculiar coaxial shape (pipe into pipe).

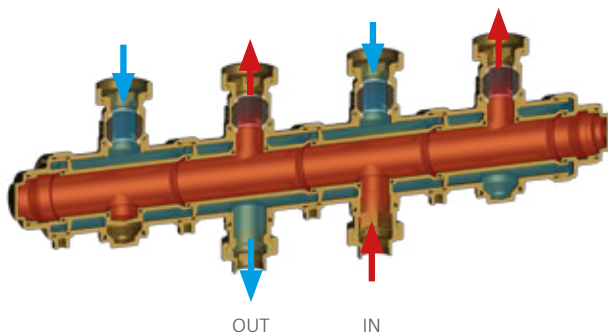

art. 5540G, for a 6.5 m³/h flow rate (up to 10 m³/h max).

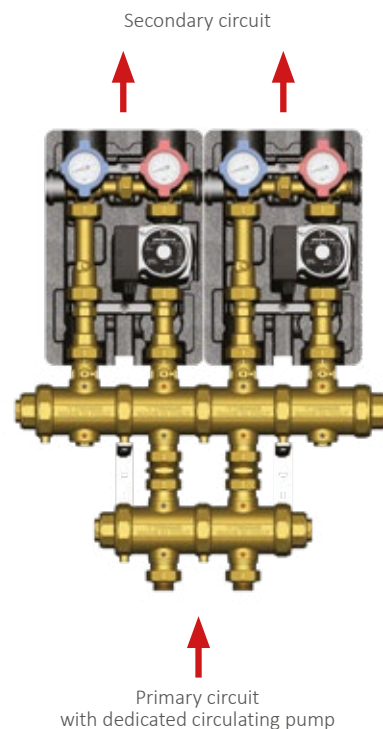
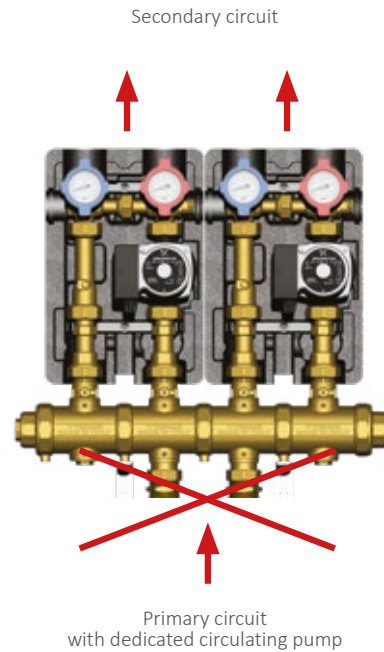
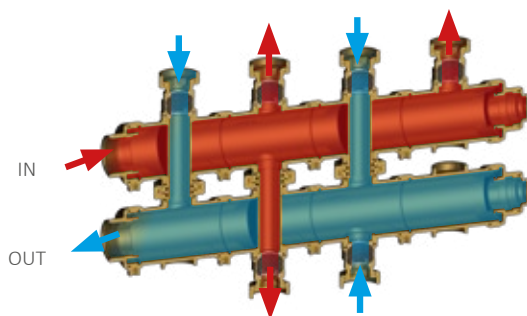

ADVANTAGES / STRENGTHS

Tiemme brass manifolds 5538G and 5540G are designed to offer a number of advantages, including:



Easy installation

Installation occurs with specific wall fixing brackets (included) on which the manifold is screwed



Ball valve

Specifically made to optimize manifold installation and maintenance operations



Compactness

Pumping and mixing stations (5535) can be installed upwards and downwards, for a higher compactness and flexibility



Insulation

The product has a heating/cooling insulation shell



Modularity

The manifold can be assembled as shown in the catalog or upon specific client requests

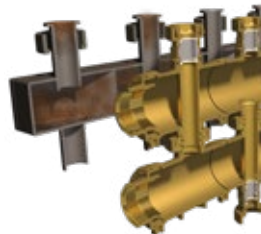

Duration

The product is entirely made in brass, thus guaranteeing improved cleanness of the system and reducing the creation of rust. However, we recommend to use a bactericide/fungicide

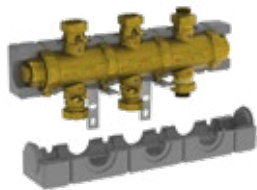

5538G2M3

Modular brass manifold for central heating system with ball valves, insulation shell and fixing brackets. 125 mm spacing, fittings with flat seat and 1"1/2 loose nut

Code	Section	No. circuits	Flow rate	Price €	Unit/Box
557 0368	2"1/2	2	2.2 (m³/h)		1/1
557 0483	2" 1/2	2	2.2 (m³/h)		1/1

5538G2M3

EXAMPLES OF ARRANGEMENTS

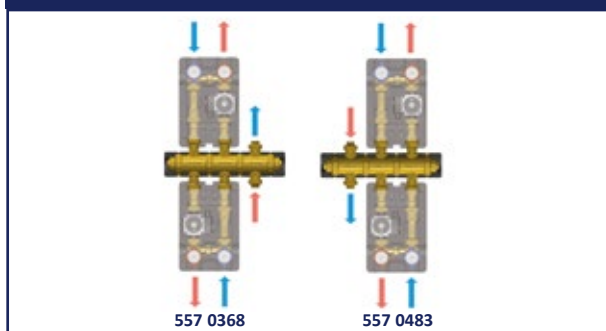

557 0368

557 0483

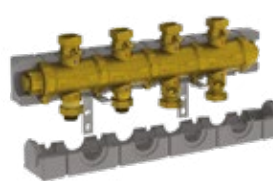

5538G3M4

Modular brass manifold for central heating system with ball valves, insulation shell and fixing brackets. 125 mm spacing, fittings with flat seat and 1"1/2 loose nut

Code	Section	No. circuits	Flow rate	Price €	Unit/Box
557 0370	2"1/2	3	2.2 (m³/h)		1/1
557 0486	2" 1/2	3	2.2 (m³/h)		1/1

5538G3M4

EXAMPLES OF ARRANGEMENTS

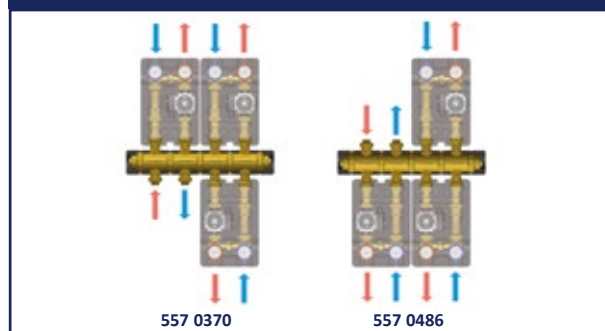

557 0370

557 0486

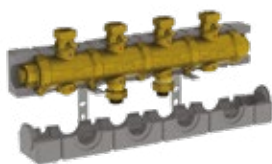

5538G2M4

Modular brass manifold for central heating system with ball valves, insulation shell and fixing brackets. 125 mm spacing, fittings with flat seat and 1"1/2 loose nut

Code	Section	No. circuits	Flow rate	Price €	Unit/Box
557 0369	2"1/2	2	2.2 (m³/h)		1/1
557 0484	2" 1/2	2	2.2 (m³/h)		1/1
557 0485	2" 1/2	2	2.2 (m³/h)		1/1

5538G2M4

EXAMPLES OF ARRANGEMENTS

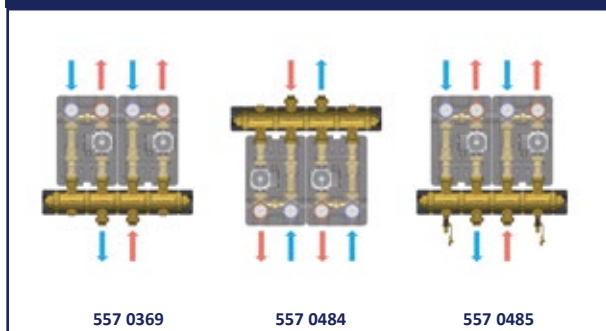

557 0369

557 0484

557 0485

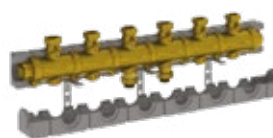

5538G3M6

Modular brass manifold for central heating system with ball valves, insulation shell and fixing brackets. 125 mm spacing, fittings with flat seat and 1"1/2 loose nut

Code	Section	No. circuits	Flow rate	Price €	Unit/Box
557 0371	2"1/2	3	2.2 (m³/h)		1/1
557 0487	2" 1/2	3	2.2 (m³/h)		1/1
557 0488	2" 1/2	3	2.2 (m³/h)		1/1

5538G3M6

EXAMPLES OF ARRANGEMENTS

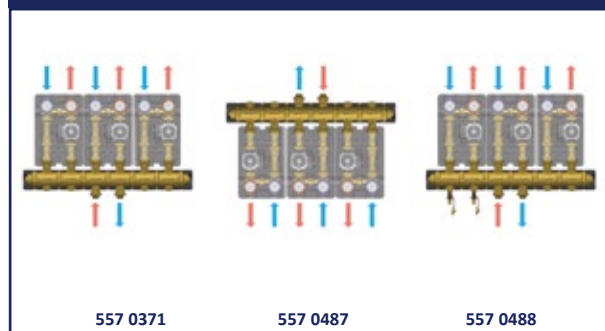

557 0371

557 0487

557 0488



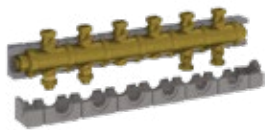

5538G4M6

Modular brass manifold for central heating system with ball valves, insulation shell and fixing brackets. 125mm spacing, fittings with flat seat and 1"1/2 loose nut

Code	Section	No. circuits	Flow rate	Price €	Unit/Box
557 0477	2"1/2	4	2.2 (m³/h)		1/1
557 0478	2" 1/2	4	2.2 (m³/h)		1/1
557 0479	2" 1/2	4	2.2 (m³/h)		1/1

5538G4M6

EXAMPLES OF ARRANGEMENTS

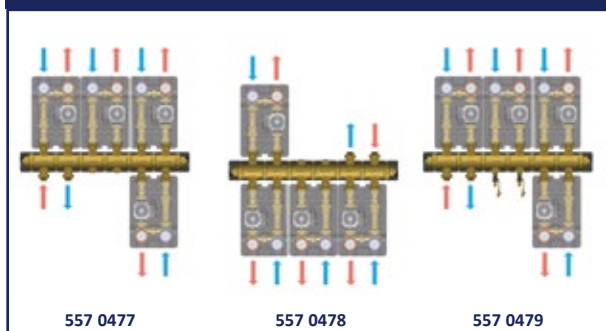

557 0477

557 0478

557 0479

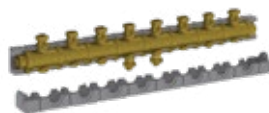

5538G4M8

Modular brass manifold for central heating system with ball valves, insulation shell and fixing brackets. 125 mm spacing, fittings with flat seat and 1"1/2 loose nut

Code	Section	No. circuits	Flow rate	Price €	Unit/Box
557 0480	2"1/2	4	2.2 (m³/h)		1/1
557 0481	2" 1/2	4	2.2 (m³/h)		1/1
557 0482	2" 1/2	4	2.2 (m³/h)		1/1

5538G4M8

EXAMPLES OF ARRANGEMENTS

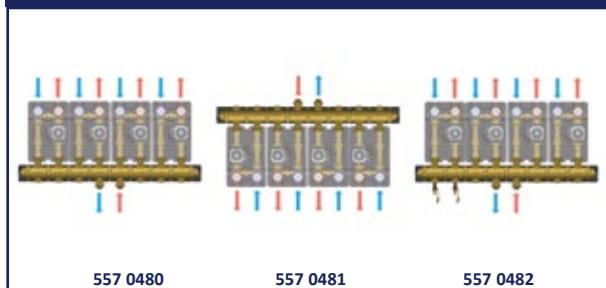

557 0480

557 0481

557 0482

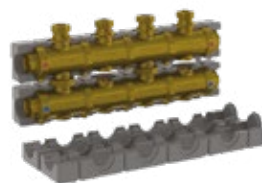

5540G2M4

Modular brass manifold for central heating system with ball valves, insulation shell and fixing brackets. 125 mm spacing, fittings with flat seat and 1"1/2 loose nut

Code	Section	No. circuits	Flow rate	Price €	Unit/Box
557 0372	2"1/2	2	6.5 (m³/h)		1/1
557 0489	2"1/2	2	6.5 (m³/h)		1/1
557 0490	2"1/2	2	6.5 (m³/h)		1/1

5540G2M4

EXAMPLES OF ARRANGEMENTS

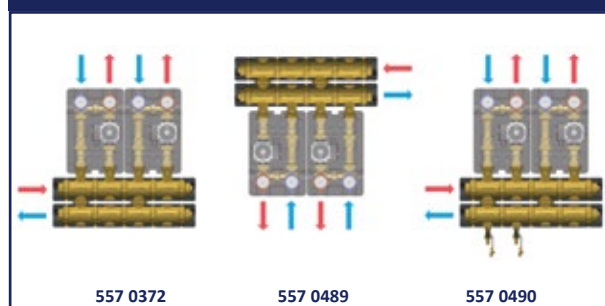

557 0372

557 0489

557 0490

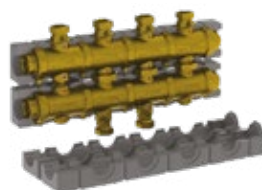

5540G3M4

Modular brass manifold for central heating system with ball valves, insulation shell and fixing brackets. 125 mm spacing, fittings with flat seat and 1"1/2 loose nut

Code	Section	No. circuits	Flow rate	Price €	Unit/Box
557 0373	2"1/2	3	6.5 (m³/h)		1/1
557 0491	2"1/2	3	6.5 (m³/h)		1/1
557 0492	2"1/2	3	6.5 (m³/h)		1/1

5540G3M4

EXAMPLES OF ARRANGEMENTS

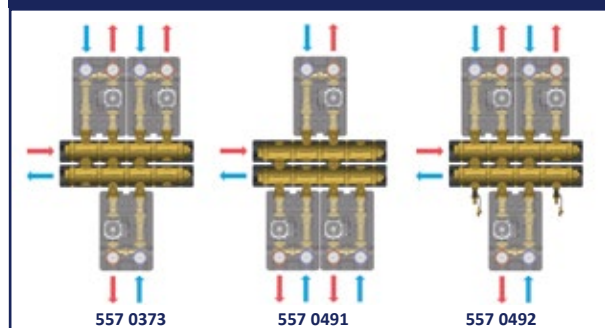

557 0373

557 0491

557 0492

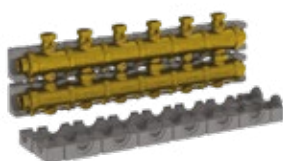

5540G3M6

Modular brass manifold for central heating system with ball valves, insulation shell and fixing brackets. 125 mm spacing, fittings with flat seat and 1"1/2 loose nut

Code	Section	No. circuits	Flow rate	Price €	Unit/Box
557 0374	2"1/2	3	6.5 (m³/h)		1/1
557 0493	2"1/2	3	6.5 (m³/h)		1/1
557 0494	2"1/2	3	6.5 (m³/h)		1/1

5540G3M6

EXAMPLES OF ARRANGEMENTS

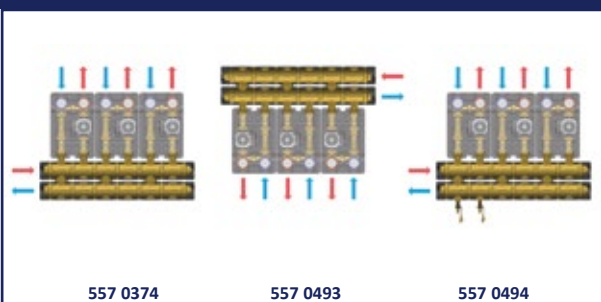

557 0374

557 0493

557 0494

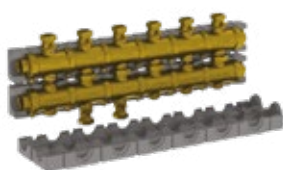

5540G4M6

Modular brass manifold for central heating system with ball valves, insulation shell and fixing brackets. 125 mm spacing, fittings with flat seat and 1"1/2 loose nut

Code	Section	No. circuits	Flow rate	Price €	Unit/Box
557 0375	2"1/2	4	6.5 (m³/h)		1/1
557 0495	2"1/2	4	6.5 (m³/h)		1/1
557 0496	2"1/2	4	6.5 (m³/h)		1/1

5540G4M6

EXAMPLES OF ARRANGEMENTS

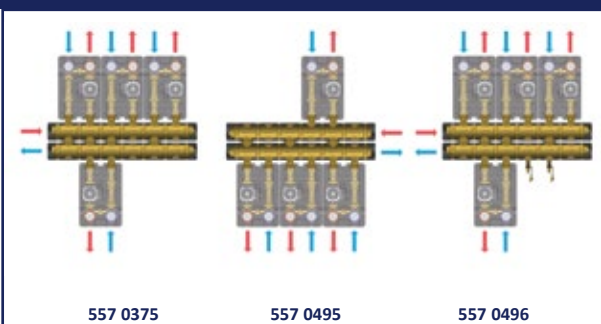

557 0375

557 0495

557 0496

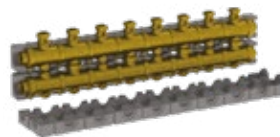

5540G4M8

Modular brass manifold for central heating system with ball valves, insulation shell and fixing brackets. 125 mm spacing, fittings with flat seat and 1"1/2 loose nut

Code	Section	No. circuits	Flow rate	Price €	Unit/Box
557 0376	2"1/2	4	6.5 (m³/h)		1/1
557 0497	2"1/2	4	6.5 (m³/h)		1/1
557 0498	2"1/2	4	6.5 (m³/h)		1/1

5540G4M8

EXAMPLES OF ARRANGEMENTS

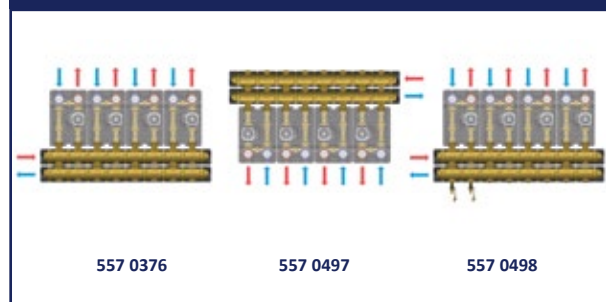

557 0376

557 0497

557 0498

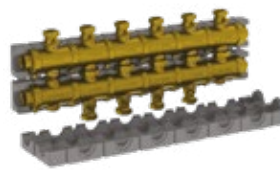

5540G5M6

Modular brass manifold for central heating system with ball valves, insulation shell and fixing brackets. 125 mm spacing, fittings with flat seat and 1"1/2 loose nut

Code	Section	No. circuits	Flow rate	Price €	Unit/Box
557 0377	2"1/2	5	6.5 (m³/h)		1/1
557 0499	2"1/2	5	6.5 (m³/h)		1/1
557 0500	2"1/2	5	6.5 (m³/h)		1/1

5540G5M6

EXAMPLES OF ARRANGEMENTS

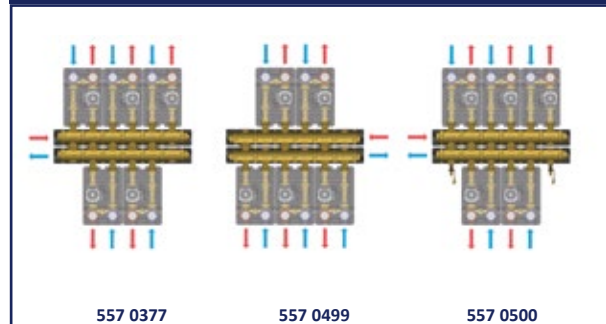

557 0377

557 0499

557 0500



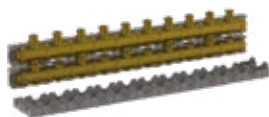

5540G5M10

Modular brass manifold for central heating system with ball valves, insulation shell and fixing brackets. 125 mm spacing, fittings with flat seat and 1"1/2 loose nut

Code	Section	No. circuits	Flow rate	Price €	Unit/Box
557 0476	2"1/2	5	6.5 (m³/h)		1/1
557 0501	2"1/2	5	6.5 (m³/h)		1/1
557 0502	2"1/2	5	6.5 (m³/h)		1/1

5540G5M10

EXAMPLES OF ARRANGEMENTS

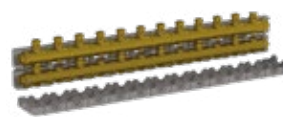
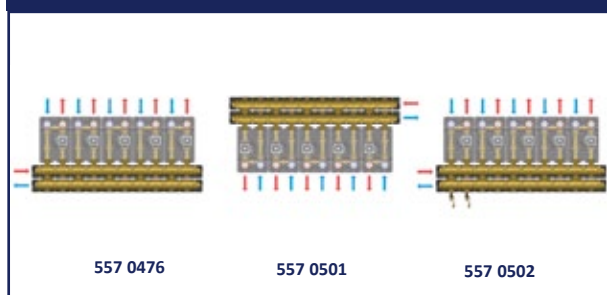

5540G6M12

Modular brass manifold for central heating system with ball valves, insulation shell and fixing brackets. 125 mm spacing, fittings with flat seat and 1"1/2 loose nut

Code	Section	No. circuits	Flow rate	Price €	Unit/Box
557 0505	2"1/2	6	6.5 (m³/h)		1/1
557 0506	2"1/2	6	6.5 (m³/h)		1/1
557 0507	2"1/2	6	6.5 (m³/h)		1/1

5540G6M12

EXAMPLES OF ARRANGEMENTS

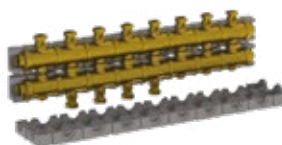
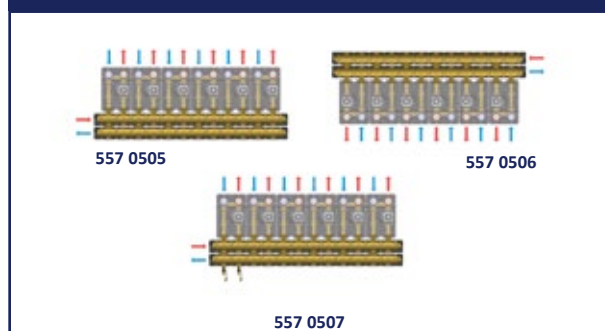

5540G6M8

Modular brass manifold for central heating system with ball valves, insulation shell and fixing brackets. 125 mm spacing, fittings with flat seat and 1"1/2 loose nut

Code	Section	No. circuits	Flow rate	Price €	Unit/Box
557 0378	2"1/2	6	6.5 (m³/h)		1/1
557 0503	2"1/2	6	6.5 (m³/h)		1/1
557 0504	2"1/2	6	6.5 (m³/h)		1/1

5540G6M8

EXAMPLES OF ARRANGEMENTS

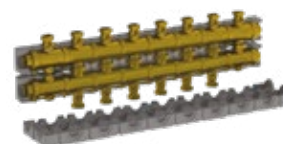
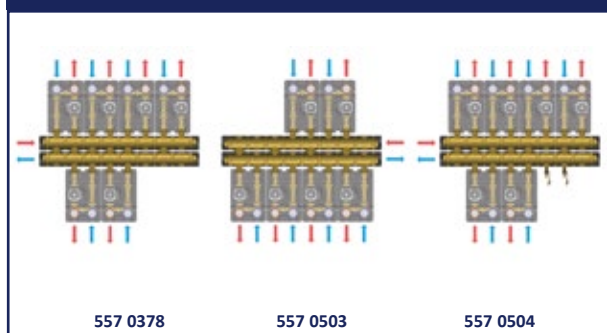

5540G7M8

Modular brass manifold for central heating system with ball valves, insulation shell and fixing brackets. 125 mm spacing, fittings with flat seat and 1"1/2 loose nut

Code	Section	No. circuits	Flow rate	Price €	Unit/Box
557 0508	2"1/2	7	6.5 (m³/h)		1/1
557 0509	2"1/2	7	6.5 (m³/h)		1/1
557 0510	2"1/2	7	6.5 (m³/h)		1/1

5540G7M8

EXAMPLES OF ARRANGEMENTS

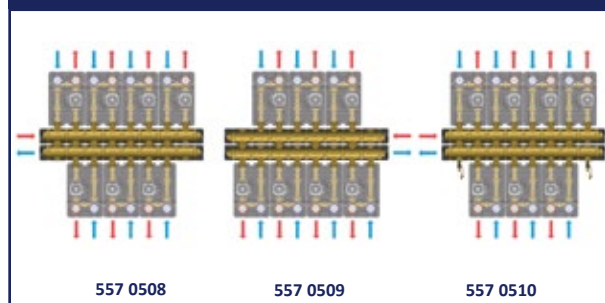



5540G7M14

Modular brass manifold for central heating system with ball valves, insulation shell and fixing brackets. 125 mm spacing, fittings with flat seat and 1"1/2 loose nut

Code	Section	No. circuits	Flow rate	Price €	Unit/Box
557 0472	2"1/2	7	6.5 (m³/h)		1/1
557 0511	2"1/2	7	6.5 (m³/h)		1/1
557 0512	2"1/2	7	6.5 (m³/h)		1/1

5540G7M14

EXAMPLES OF ARRANGEMENTS

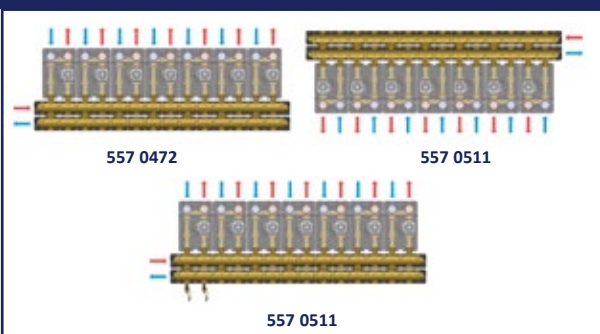

IMPORTANT
specific arrangements are possible depending
on CLIENT NEEDS



5538G - 5540G GUIDE TO FITTINGS

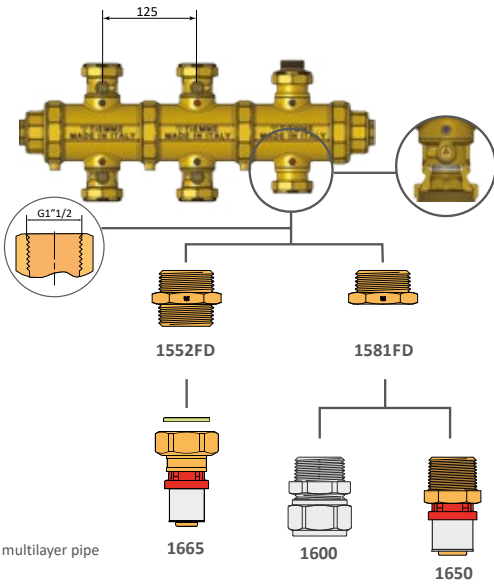
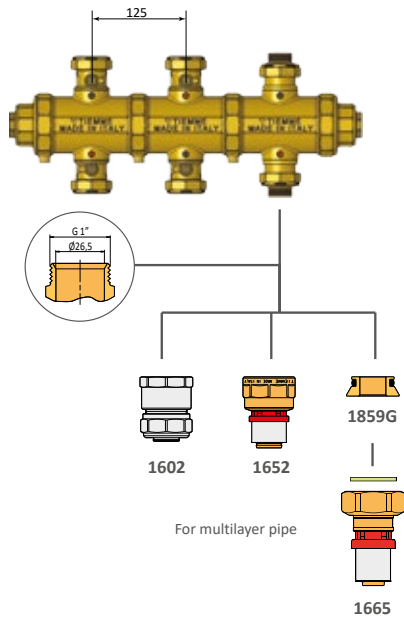

5540G GUIDE TO FITTINGS

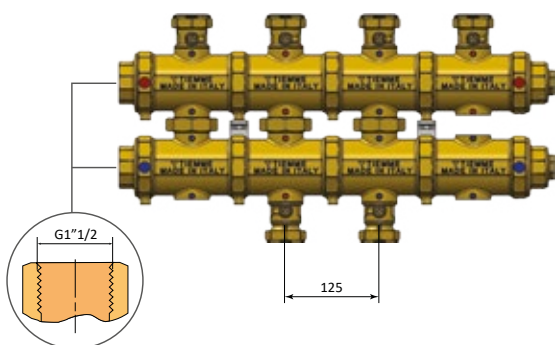

5538G - 5540G INSTALLATION

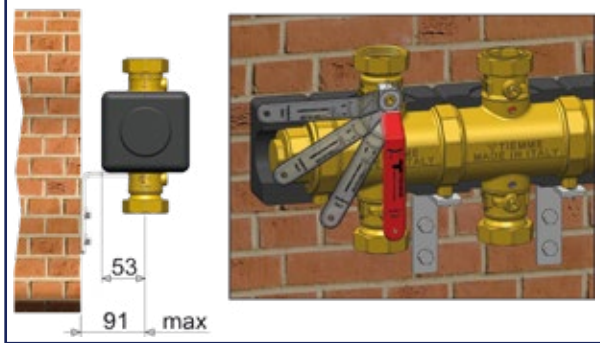

Wall installation is quick and easy, thanks to the specific adjustable brackets that can be screw-fixed onto the wall and to the manifold. Screw slots can be found directly on the manifold. With the ball valve installed on the manifold, it is possible to perform maintenance by shutting down the relevant line, without stopping the rest of the system, which can be kept operational.

5538G DIMENSIONS

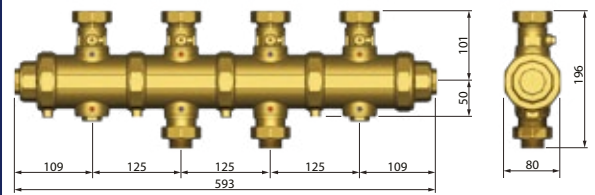

5540G DIMENSIONS

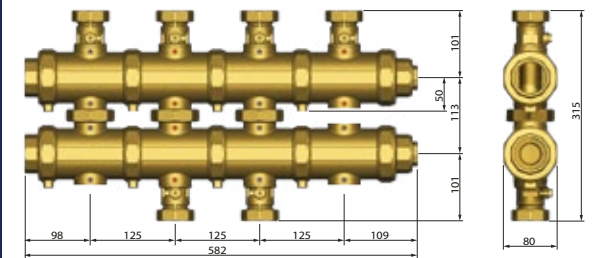



1602
Female straight fitting for multilayer pipe

Code	Type	Price €	Unit/Box
160 0112	25 x 2.5 - 1"		5/50
160 0029	26 x 3.0 - 1"		5/100
160 0039	32 x 3.0 - 1"		5/50



1652
Female straight fitting for multilayer pipe

Code	Type	Price €	Unit/Box
165 0268	25 x 2.5 - 1"		5/25
165 0053	26 x 3.0 - 1"		5/25
165 0050	32 x 3.0 - 1"		5/25



1665
Straight fitting with swivel nut and flat-sealing for multilayer pipe

Code	Type	Price €	Unit/Box
165 0233	25 x 2.5 - 1"		2/50
165 0071	26 x 3.0 - 1"		2/50
165 0134	32 x 3.0 - 1"		2/100
165 0239	40 x 3.5 - 1"1/2		1/25

To be installed with 1859

To be installed with 1552FD



1859
Adapter to turn 1" G connection into plain end

Code	Type	Price €	Unit/Box
144 0234	1" G		10/300



1552FD
Male threaded nipple with flat seat

Code	Type	Price €	Unit/Box
471 0086	1"1/2 x 1"1/2		2/30



1881
M/F reduction with O-ring for manifolds

Code	Type	Price €	Unit/Box
195 0066	1" 1/2 x 3/4"		5/70



1828Z
Multi-screw bracket for central heating system manifolds

Code	Type	Price €	Unit/Box
179 0323	single		1/25



2095R
Red steel flat handle

Code	Type	Price €	Unit/Box
209 0069	single		1/10



2121CP
ISO 228 male-female ball valve with aluminum handle for manifolds and FLAT WASHER

Code	Type	Price €	Unit/Box
 212 0122	red handle 1"1/2		3/12
 212 0124	black handle 1"1/2		3/12



DN25 pumping station, art. 5535G, feeds high temperature circuits of heating systems, directly from manifold's connections, without changing the temperature of the incoming fluid. Two thermometers make it possible to check instantaneous flow and return temperature. A check valve is located on the return way that prevents the fluid from self-circulate when the circulating pump is off. The unit can be complemented by optional components, such as differential by-pass (art. 5535DIFF) and/or safety thermostat and pad (art. 2075KIT03).



1. Inflow ball valve with thermometer
2. Circulating pump (if equipped)
3. Inflow
4. Return
5. EPP insulation shell
6. Fixing brackets
7. Check valve
8. Return way
9. Return ball valve with thermometer

PRODUCT RANGE



5535G
Pumping station



TECHNICAL SPECIFICATIONS

- Body material: CW 617 N Brass
- Gasket material: EPDM
- Insulating shell material: EPP
- Size: DN25 (1")
- Connections distance between axes 125 mm:
 - Inlet: 1"1/2 male with plain end
 - Outgo: 1"1/2 male with plain end
- Max operating P: 8 bar
- Max operating T: 110°C

Code	Type	Price €	Unit/Box
316 0017	Without circulating pump		1/1
316 0043	Wilo PARA 25/7		1/1
316 0042	UPM3 HYBRID 25/70		1/1
316 0090	Wilo PARA 25/9		1/1
316 0018	Grundfos UPS 25-65		1/1

ErP READY

Available for non-UE countries

DIAGRAM OF PRESSURE DROP CIRCULATING PUMP HEAD

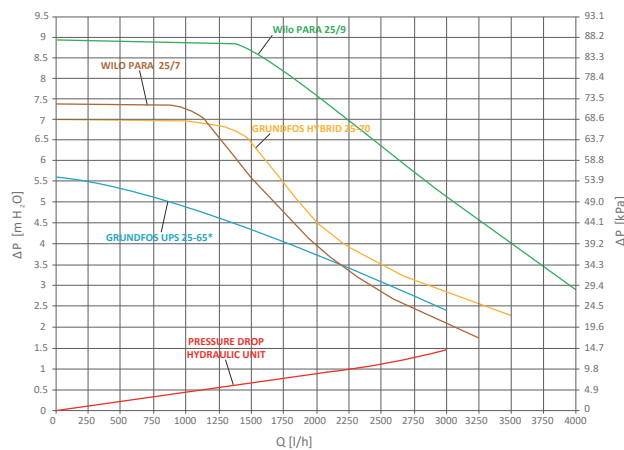

DN25 pumping station, art. 5535GPF, feeds high temperature circuits of heating systems, directly from manifold's connections, without changing the temperature of the incoming fluid. Two thermometers make it possible to check instantaneous flow and return temperature. A check valve is located on the return way that prevents the fluid from self-circulate when the circulating pump is off. Moreover, the mixing unit comes with a safety contact thermostat (intervention temperature: 55°C) to protect the system. The unit can be complemented by optional components, such as differential by-pass (art. 5535DIFF) and/or safety thermostat and pad (art. 2075KIT03).

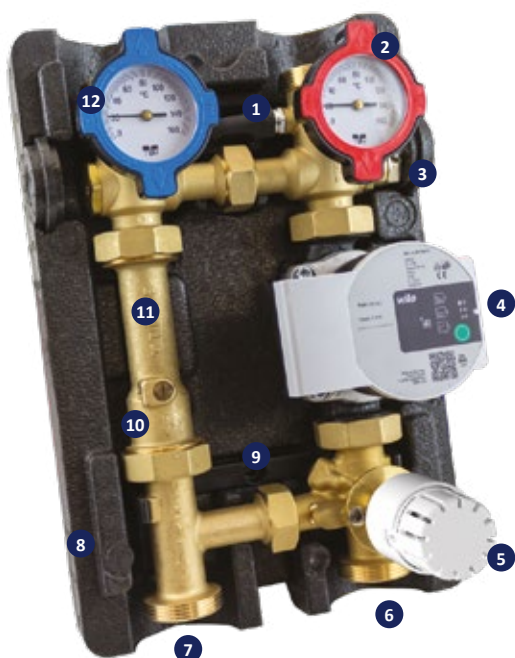

1. Safety thermostat
2. Inflow ball valve with thermometer
3. Sensor-supporting well with nipple
4. Circulating pump (if equipped)
5. 3-way mixing valve with thermostatic head
6. Inflow
7. Return
8. EPP insulation shell
9. Fixing brackets
10. Check valve
11. Return way
12. Return ball valve with thermometer

PRODUCT RANGE



5535GPF

Fixed point mixing unit



TECHNICAL SPECIFICATIONS

- Body material: CW 617 N Brass
- Gasket material: EPDM
- Insulating shell material: EPP
- Size: DN25 (1")
- Connections distance between axes 125 mm:
 - Inlet: 1"1/2 male with plain end
 - Outgo: 1"1/2 male with plain end
- Max operating P: 8 bar
- Max operating T: 110°C
- Temperature control: 20÷50°C
- Safety thermostat: 55°C

Code	Type	Price €	Unit/Box
316 0020	Without circulating pump		1/1
316 0046	Wilo PARA 25/7		1/1
316 0045	Grundfos UPM3 HYBRID 25/70		1/1
316 0091	Wilo PARA 25/9		1/1
316 0021	Grundfos UPS 25-65		1/1

ErP READY

Available for non-UE countries

DIAGRAM OF PRESSURE DROP CIRCULATING PUMP HEAD

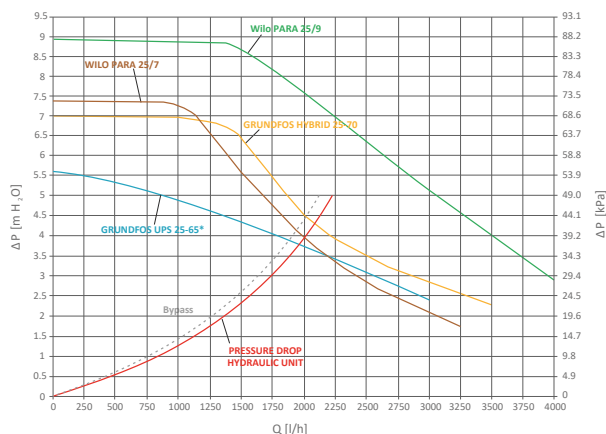

DN25 pumping station, art. 5535G3P, feeds high temperature circuits of heating systems, directly from manifold's connections, without changing the temperature of the incoming fluid. Two thermometers make it possible to check instantaneous flow and return temperature. A check valve is located on the return way that prevents the fluid from self-circulate when the circulating pump is off. The unit can be complemented by optional components, such as differential by-pass (art. 5535DIFF) and/or safety thermostat (art. 2075KIT03).



1. Inflow ball valve with thermometer
2. Ø 6mm sensor well with nipple
3. Circulating pump (if equipped)
4. 3-way mixing valve with servomotor
5. Inflow
6. Return
7. EPP insulation shell
8. Fixing brackets
9. Check valve
10. Return way
11. Return ball valve with thermometer

PRODUCT RANGE



5535G3P

Mixing unit with servomotor



TECHNICAL SPECIFICATIONS

- Body material: CW 617 N Brass
- Gasket material: EPDM
- Insulating shell material: EPP
- Size: DN25 (1")
- Connections distance between axes 125 mm:
 - Inlet: 1"1/2 male with plain end
 - Outgo: 1"1/2 male with plain end
- Max operating P: 8 bar
- Max operating T: 110°C

SERVOMOTOR

- Power supply: 230 Vac SPDT control (3 ways)
- Rotation time: 120 secs (90° angle)
- Rated torque: 7 Nm

Code	Type	Price €	Unit/Box
316 0023	Without circulating pump		1/1
316 0049	Wilo PARA 25/7		1/1
316 0048	Grundfos UPM3 HYBRID 25/70		1/1
316 0092	Wilo PARA 25/9		1/1
316 0024	Grundfos UPS 25-65		1/1

ErP READY

Available for non-UE countries

DIAGRAM OF PRESSURE DROP CIRCULATING PUMP HEAD

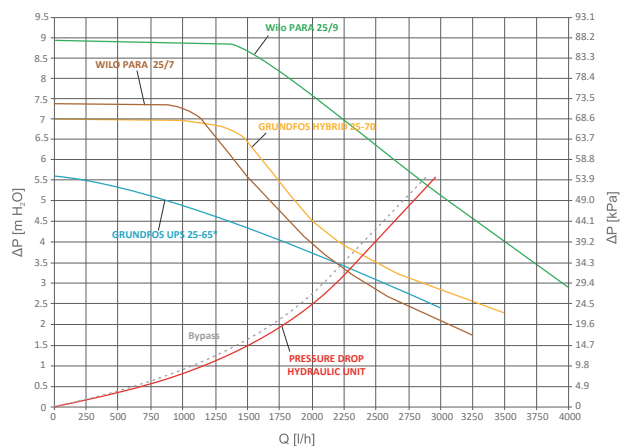

DN25 pumping station, art. 5536G, is a model of 5535G series designed to create cooling systems. To this purpose, the station has an EPP insulation shell that can reduce the creation of steam on metal surfaces. The station feeds circuits of heating/cooling systems from a manifold connections, without changing the temperature of the incoming fluid. Two thermometers allow to check instantaneous flow and return temperature. A check valve is located on the return way that prevents the fluid from self-circulate when the circulating pump is off. The unit can be complemented by optional components, such as differential by-pass (art. 5535DIFF) and/or safety thermostat and pad (art. 2075KIT03).



1. Inflow ball valve with thermometer
2. Circulating pump (if equipped)
3. Inflow
4. Return
5. Pex foam insulation shell
6. Fixing brackets
7. Check valve
8. Return way
9. Return ball valve with thermometer

PRODUCT RANGE



5536G

Pumping station with insulation shell for cooling purposes



TECHNICAL SPECIFICATIONS

- Body material: CW 617 N Brass
- Gasket material: EPDM
- Insulating shell material: Foamed closed-cell PE-X
- Size: DN25 (1")
- Connections distance between axes 125 mm:
 - Inlet: 1"1/2 male with plain end
 - Outgo: 1"1/2 male with plain end
- Max operating P: 8 bar
- Max operating T: 110°C

Code	Type	Price €	Unit/Box
557 0383	Without circulating pump		1/1
557 0386	Wilo PARA 25/7		1/1
557 0559	Wilo PARA 25/9		1/1

ErP READY

DIAGRAM OF PRESSURE DROP CIRCULATING PUMP HEAD

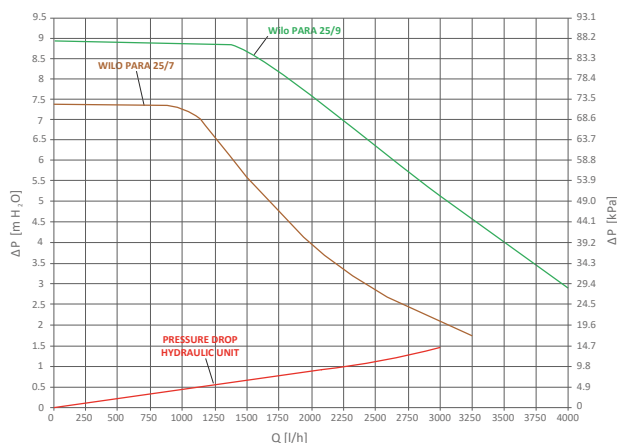

DN25 pumping station, art. 5536GS, is a model of 5535G3P series designed to create cooling systems. To this purpose, the unit has an EPP insulation shell that can reduce the creation of steam on metal surfaces. The unit feeds heating/cooling system circuits, directly from manifold connections, changing the temperature of the incoming fluid into the design value (thanks to the mixing valve controlled by a servomotor). Two thermometers make it possible to check instantaneous flow and return temperature. A check valve is located on the return way that prevents the fluid from self-circulate when the circulating pump is off. The unit can be complemented by optional components, such as differential by-pass (art. 5535DIFF) and/or safety thermostat (art. 2075KIT03).

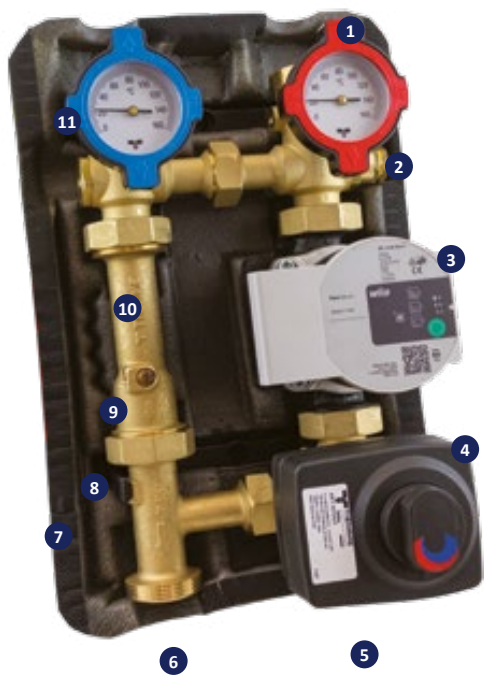

1. Inflow ball valve with thermometer
2. Ø 6mm sensor well with nipple
3. Circulating pump (if equipped)
4. 3-way mixing valve with servomotor
5. Inflow
6. Return
7. PEX foam insulation shell
8. Fixing brackets
9. Check valve
10. Return way
11. Return ball valve with thermometer

PRODUCT RANGE



5536GS

Mixing unit with insulation shell with servomotor for cooling purposes



TECHNICAL SPECIFICATIONS

- Body material: CW 617 N Brass
- Gasket material: EPDM
- Insulating shell material: Foamed closed-cell PE-X
- Size: DN25 (1")
- Connections distance between axes 125 mm:
 - Inlet: 1"1/2 male with plain end
 - Outgo: 1"1/2 male with plain end
- Max operating P: 8 bar
- Max operating T: 110°C

SERVOMOTOR

- Power supply: 24 Vac (0-10Vdc control)
- Rotation time: 120 secs (90° angle)
- Rated torque: 7 Nm

Code	Type	Price €	Unit/Box
557 0388	Without circulating pump		1/1
557 0391	Wilo PARA 25/7		1/1
557 0560	Wilo PARA 25/9		1/1

ErP READY

DIAGRAM OF PRESSURE DROP CIRCULATING PUMP HEAD

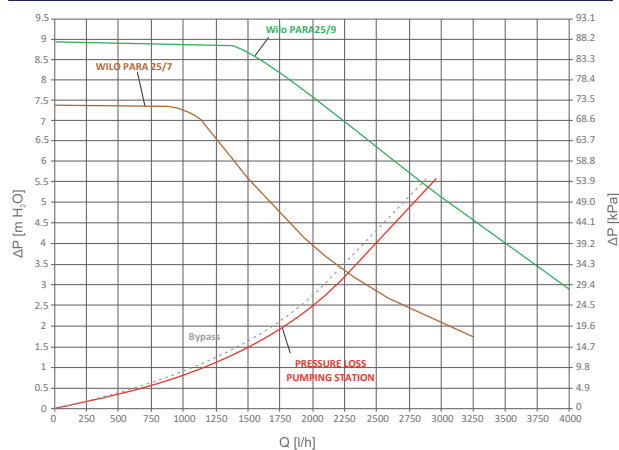

DN32 pumping station, art. 5534G, feeds high temperature circuits of heating systems, directly from manifold's connections, without changing the temperature of the incoming fluid. Two thermometers make it possible to check instantaneous flow and return temperature. A check valve is located on the return way that prevents the fluid from self-circulate when the circulating pump is off.

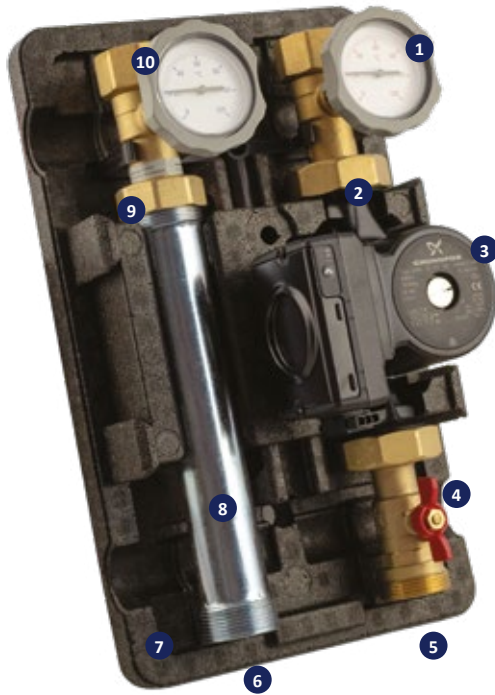

1. Inflow ball valve with thermometer
2. Check valve
3. Circulating pump (if equipped)
4. Pump fitting valve
5. Inflow
6. Return
7. Insulation shell
8. Return way
9. Check valve
10. Return ball valve with thermometer

PRODUCT RANGE



5534G

Pumping station



TECHNICAL SPECIFICATIONS

- Body material: CW 617 N Brass
- Gasket material: EPDM
- Insulating shell material: EPP
- Size: DN32 (1"1/4)
- Connections distance between axes 125 mm:
 - Inlet: 1"1/2 male with plain end
 - Outlet: 1"1/4 female
- Max operating P: 8 bar
- Max operating T: 110°C

Code	Type	Price €	Unit/Box
316 0093	Without circulating pump		1/1
316 0095	Grundfos UPML 32-105 AUTO		1/1

ErP READY

DIAGRAM OF PRESSURE DROP CIRCULATING PUMP HEAD

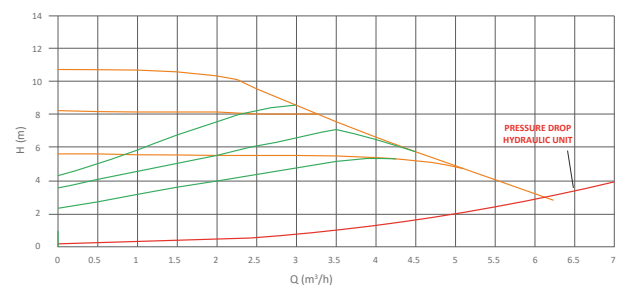

- Functioning with constant flow rate
- Functioning with variable flow rate
- Unit pressure drop



DN32 pumping station, art. 5534G3P, feeds high temperature circuits of heating systems, directly from manifold's connections, without changing the temperature of the incoming fluid (function guaranteed by the mixing valve controlled by a servomotor - accessory art. 9562SERV to be purchased separately). Two thermometers make it possible to check instantaneous flow and return temperature. A check valve is located on the return way that prevents the fluid from self-circulate when the circulating pump is off.

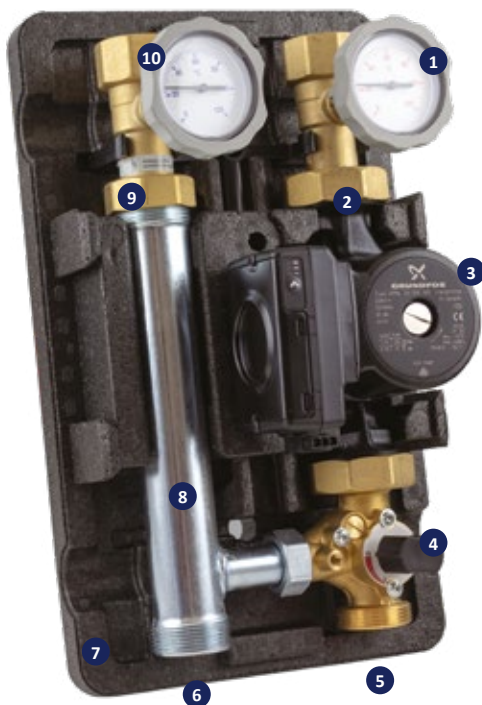

1. Inflow ball valve with thermometer
2. Check valve
3. Circulating pump (if equipped)
4. Mixing valve (optional servomotor)
5. Inflow
6. Return
7. Insulation shell
8. Return way
9. Check valve
10. Return ball valve with thermometer

PRODUCT RANGE



5534G3P

Mixing unit for servomotor (not included)



TECHNICAL SPECIFICATIONS

- Body material: CW 617 N Brass
- Gasket material: EPDM
- Insulating shell material: EPP
- Size: DN 32
- Connections distance between axes 125 mm:
 - Inlet: 1"1/2 male with plain end
 - Outlet: 1"1/4 female
- Max operating P: 8 bar
- Max operating T: 110°C

 To be complemented with servomotor 9562SERV

Code	Type	Price €	Unit/Box
316 0097	Without circulating pump		1/1
316 0099	Grundfos UPML 32-105 AUTO		1/1

 ErP READY

DIAGRAM OF PRESSURE DROP CIRCULATING PUMP HEAD

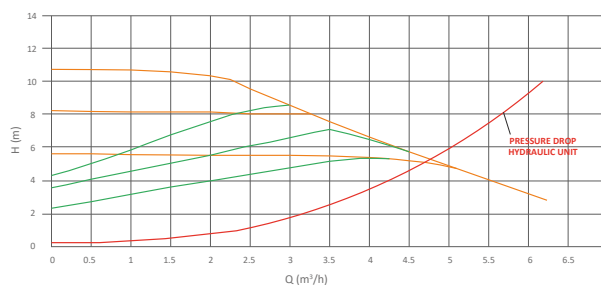

- Functioning with constant flow rate
- Functioning with variable flow rate
- Unit pressure drop



5535DIFF

Differential by-pass with 50-400 mbar settings. M25x1.5 fitting. (Can be used with any hydraulic power unit)

Code	Type	Price €	Unit/Box
316 0029	50-400 mbar		1/50



2075KIT03

Safety thermostat including a cable with straight connection

Code	Type	Price €	Unit/Box
557 0024	55 °C		1/1



3880GPF

Mixing valve for fixed point adjustment

i To be complemented with 9561KIT02 thermostatic kit

Code	Type	Price €	Unit/Box
316 0030	-		1/4



9561KIT02

Nipple + well + thermostatic head 20-50 °C kit with distance sensor. M30x1.5 fitting

i To be used with 5535GPF fixed point mixing unit

Code	Type	Price €	Unit/Box
450 0150	20-50 °C		1/10



3880GSM

Mixing valve for servomotor controller (not included)

i To be complemented with servomotor 9562SERV

Code	Type	Price €	Unit/Box
316 0031	-		1/4



9562SERV

Servomotor including a kit to connect to 3880GSM mixing valve

TECHNICAL SPECIFICATIONS

- Body material: Self-extinguishing PA FV
- Rotation time: 120 secs
- Rotation angle: 90°
- Rated torque: 7 Nm
- Protection rating: IP 40
- Power supply:
 - 230 Vac SPDT (3 points)
 - 24 Vac SPDT (3 points)
 - 24 Vac (0 - 10 Vdc)

Code	Type	Price €	Unit/Box
557 0023	230 Vac SPDT (3 points)		1/8
557 0306	24 Vac SPDT (3 points)		1/8
557 0307	24 Vac 0-10 Vdc		1/8



4745MANOP

Handle with immersion thermometer for hydraulic power units

Code	Type	Price €	Unit/Box
470 0183	Blue		10/40
470 0184	Red		10/40



5537KIT

Nipple + well kit for Ø6 mm sensor. M25x1.5 fitting

i To be used with 5535G3P mixing unit with servomotor

Code	Type	Price €	Unit/Box
557 0022	-		1/25





1665
Straight fitting with swivel nut and flat-sealing for multilayer pipe

Code	Type	Price €	Unit/Box
165 0240	32 x 3.0 - 1"1/2		1/50
165 0239	40 x 3.5 - 1"1/2		1/25



1557SET
Brass female pump connection kit with flat end

i The kit includes: 2 tails, 2 nuts and 2 gaskets

Code	Type	Loose nut	Price €	Unit/Box
150 0355	1"	1"1/2		1/20



3890PW2
Wilo PARA 25/7 high efficiency pump with 130 mm spacing

+ HIGH-EFFICIENCY PUMP

Code	Type	Price €	Unit/Box
450 0358	Wilo PARA 25/7		1/1



3890PW5
Wilo PARA 25/9 high efficiency pump with 130 mm spacing. 1"1/2 fitting on cast iron body

+ HIGH-EFFICIENCY PUMP

Code	Type	Price €	Unit/Box
450 0557	Wilo PARA 25/9		1/1



3890PV
Grundfos UPSM3 HYBRID 25/70 high efficiency pump with 130 mm spacing. 1"1/2 fitting on cast iron body

+ HIGH-EFFICIENCY PUMP

Code	Type	Price €	Unit/Box
450 0091	Grundfos UPM3 HYBRID 25/70		1/1



3890P
Grundfos UPS 25-55 3 speed pump with 130 mm spacing. 1"1/2 fitting on cast iron body

Code	Type	Price €	Unit/Box
450 0033	Grundfos UPS 25-55		1/1

Available for non-UE countries



3890PU
High-efficiency pump. 2" fittings with 180 mm spacing

+ HIGH-EFFICIENCY PUMP

Code	Type	Price €	Unit/Box
450 0637	Grundfos UPML 32-105		1/1

SINGLE-FAMILY SYSTEM

Single-family radiant heating/cooling system with boiler and heat pump. Tiemme brass manifold, **art. 5538G2M4**, with Tiemme hydraulic separator, **art. 7166**.

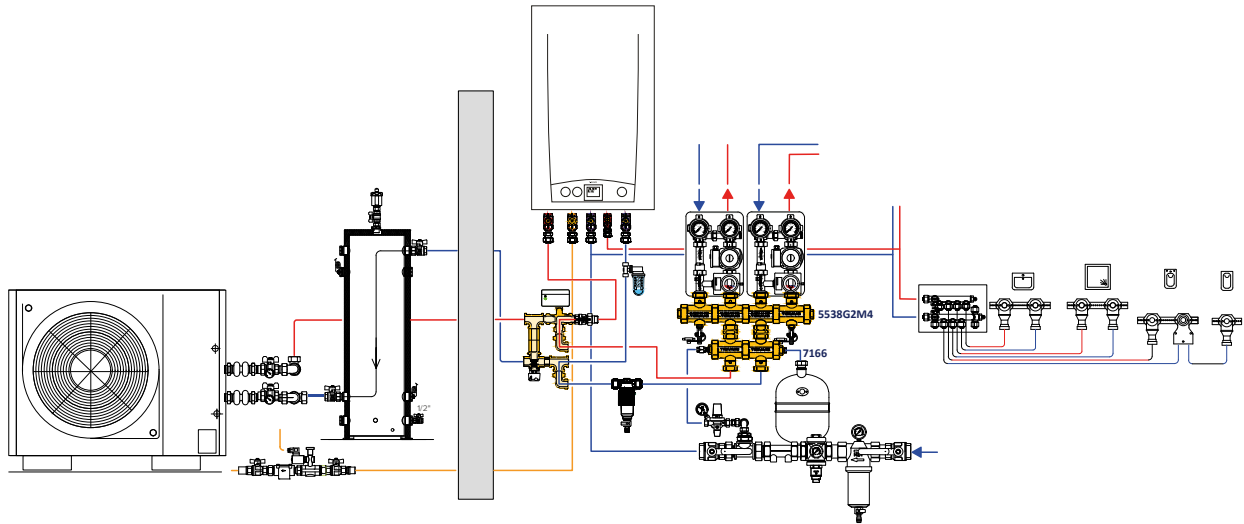

MULTI-FAMILY SYSTEM

Multi-family system with cascade heating generators Tiemme brass manifold, **art. 5540G6M12**, and Tiemme hydraulic separator, **art. 3144**, including drain cock and deaerator.

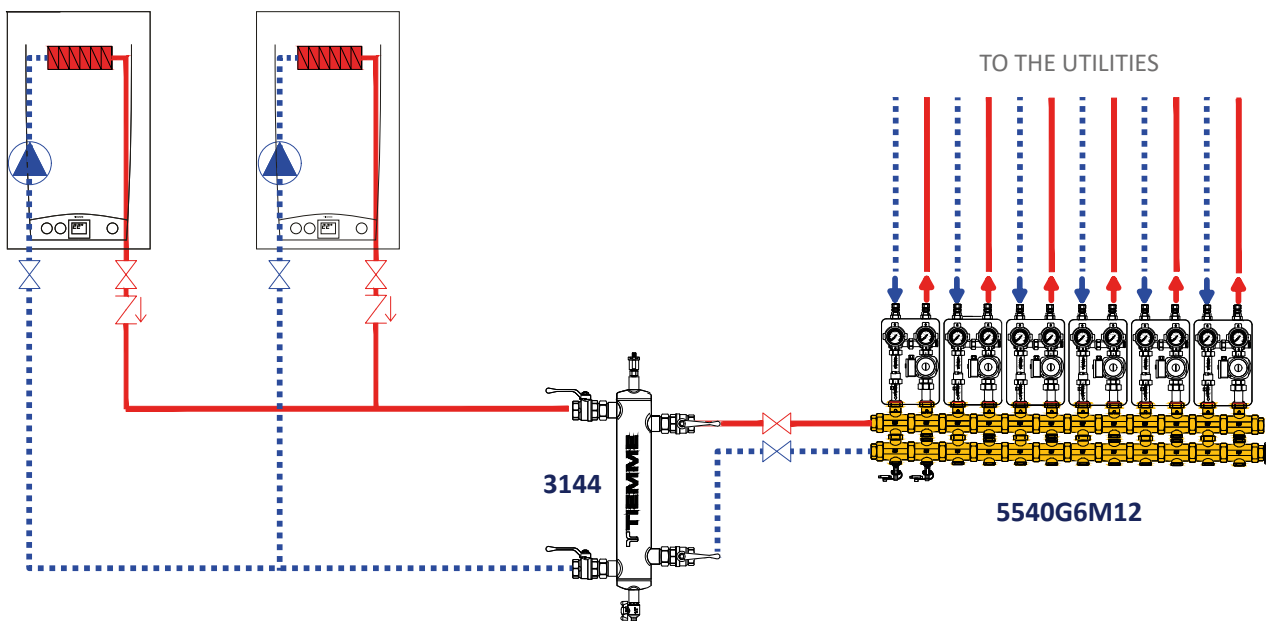

03

DIRT SEPARATOR FILTERS AND AIR VENTS

03A Magnetic dirt separator filters

The reason behind filtration treatment in plants

58

Magnetic dirt separator filters



59

03B Polyphosphates proportional dispenser



64

03C Acid condensate neutralizer filters



65

03D Air vent valves

Air in the systems: common issues

66

Automatic air vent valves



67

Deaerators



70

Air vent valves for radiators



71

Accessories



71

The water circulating in heating and cooling systems is commonly subject to the presence of impurities (sand grains, residues resulting from installation and maintenance operations, rust flakes caused by oxidation and corrosion phenomena, etc....). These impurities, if not properly removed, may cause, even in the short run, a number of problems, in particular:

- Corrosion phenomena caused by the deposition of impurities on the pipe walls (corrosion by differential aeration)
- Erratic operation of the adjustment and balance components
- Blockage and seizure of circulation pumps
- Occlusion of the heat exchangers
- Hindrance to heat from being transmitted evenly by the terminal elements

The result is an increase in the cost of running and maintenance of the plant.

The guarantee on the generators shouldn't be underestimated either: Boiler manufacturers often invalidate the guarantee conditions if their product is not adequately protected with a filter, from the very first commissioning.

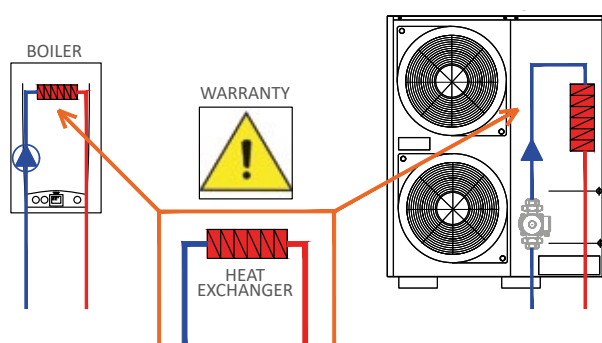

THE TIEMME SOLUTION

Water treatment is an increasingly topical subject to which a great deal of sensitivity must be given and addressed through the installation of adequate protection/filtration devices. Magnetic filtration is the most effective method of removing ferrous particles (magnetite) from heating systems.

The advantage of the magnetic filter lies in its ability to remove almost completely the ferrous oxides that form in the system due to corrosive phenomena, since they are attracted by the magnetic field generated by the powerful magnets.

The installation of a Tiemme magnetic filter, combined with routine maintenance, allows to improve the overall energy efficiency of the system, reducing consumption and CO₂ emissions, ensuring a longer life of the heating system.

PRINCIPLE OF OPERATION

The water, entering the large filtration chamber, undergoes a sudden decrease in the flow rate, favoring the sedimentation of impurities. For this purpose it is recommended to maintain the maximum flow speed in the order of 1 ÷ 1,5 m/s.

In addition, Tiemme magnetic dirt separator filters ensure effective separation of debris due to magnetic and mechanical action. The magnet attracts ferrous impurities, while the filter mesh captures larger particle impurities*.

The constant running of the fluid through the filter, during normal operation of the system where it is installed, gradually leads to the complete removal of impurities.

*Check the characteristics of each filter model shown on the following pages.

SCOPE

Tiemme magnetic dirt separator filter is ideal for installation in new plants. It is also used in long-running heating systems to restore energy efficiency.



03A MAGNETIC DIRT SEPARATOR FILTERS

"TM-MAG MINI" COMPACT FILTER FOR UNDER-BOILER INSTALLATION

The magnetic filter for under-boiler installation **TM-MAG MINI** ensures effective removal of impurities in heating circuits, thanks to the combined double action:

- The neodymium magnet attracts ferrous particles by the action of the magnetic field;
- The filter cartridge mechanically filters the impurities with a particle size of up to 800 µm;

The compact dimensions allow the installation of TM-MAG MINI even in extra small spaces, new or existing boilers (e.g. home boilers installed inside kitchen cabinets).

Designed for home applications.

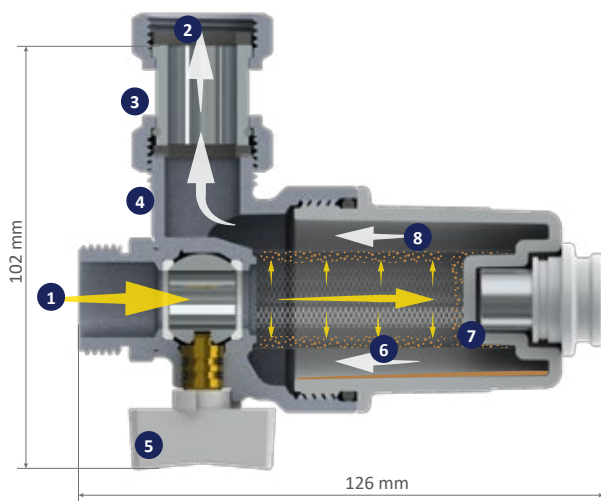
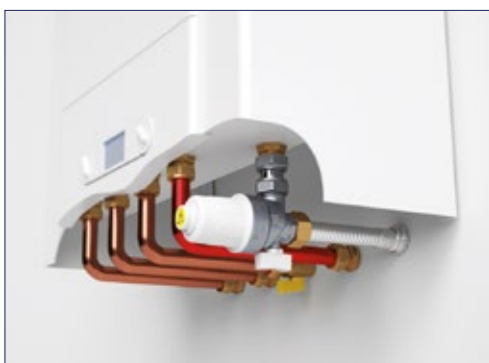

1. System return - fluid to be treated inlet
2. Boiler inlet - treated water filter outlet
3. Straight connection with loose nut. G 3/4" union for boiler connection.
4. Brass main body.
5. Integrated shut-off ball valve on the filter: allows the dirt separator to be isolated from the system for periodic cleaning, emptying only the water contained in the filter cartridge holder cup.
6. Filter cartridge 800 µm.
7. 12,000 Gauss neodymium detachable magnet
8. Filter cartridge holder cup.

PRODUCT RANGE



3150

TM-MAG MINI Compact magnetic filter for under-boiler installation



TECHNICAL SPECIFICATIONS

- Degree of filtration: 800 µm
- Body material: Brass CW617N/ PA6.6 30% F.V.
- Max. operating temperature: 90°C

Code	Type	Price €	Unit/Box
315 0039	3/4"		1/10

03A MAGNETIC DIRT SEPARATOR FILTERS

“TM-MAG EVO” UNDER-BOILER FILTER

TM-MAG EVO filters out impurities in air conditioning systems thanks to the combined action of magnets, a filtering net, a large sediment chamber:

- The fluid is directed towards the powerful neodymium magnets that attracts and stops metallic impurities.
- It then goes through the 800 µm stainless steel filtering mesh that captures the remaining dirt particles.
- The tiniest particles are deposited on bottom thanks to a large sediment chamber.

In this way the impurities do not enter the plant but are deposited in the cup, ready to be evacuated during periodic cleaning of the filter.

TM-MAG EVO can be installed in either vertical or horizontal position, without ever losing efficiency in the protection of the boiler.

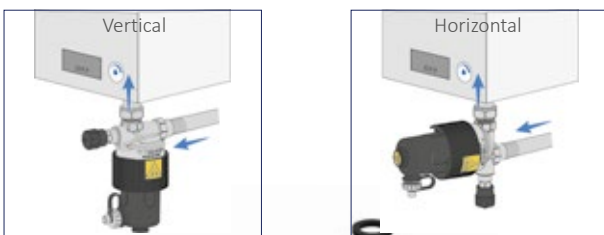

1. By-pass
2. Main body in brass
3. Filter cartridge holder cup
4. Drain cap
5. Straight coupling with swivel.
G 3/4" connection for coupling with the boiler
6. 800 µm filter cartridge
7. Neodymium magnets 12,000 gauss

DEDICATED WEBSITE



TM-MAG EVO Dirt separator filter

THE ADVANTAGES OF THE BY-PASS

The TM-MAG EVO by-pass allows to completely divert the fluid excluding the passage inside the filtration chamber and therefore allowing periodic cleaning operations even when the system is on.

By emptying only the water contained in the filter holder, the dispersion of water treated with chemical additives is minimized, thus avoiding the need to replenish the system from the mains, with the possibility of retrigger chemical/physical processes of corrosion of the plant.

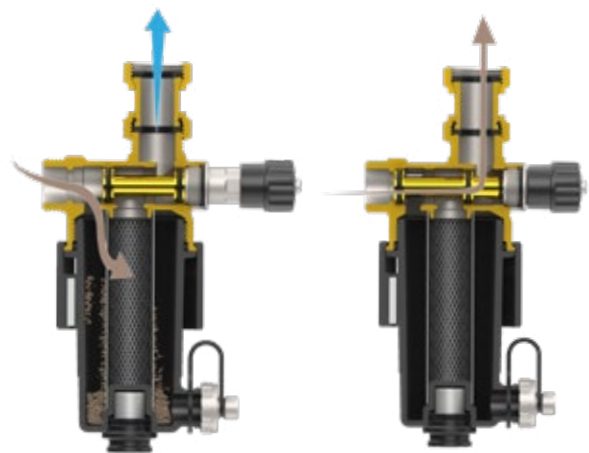

By-pass open:
filter on

By-pass closed:
filter off.
Maintenance operations are permitted

PRODUCT RANGE

NEW



3154

TM-MAG EVO Under-boiler magnetic dirt separator filter with by-pass



TECHNICAL CHARACTERISTICS

- Performance: 800 µm
- Body: CW617N brass nickel-plated
- Max operating temperature: 95°C

WITH BY-PASS

Code	Type	Price €	Unit/Box
315 0071	3/4"		1/5

NEW



3154C

Kit (tap + gasket) for under-boiler magnetic filter with by-pass (Art. 3154)

Code	Type	Price €	Unit/Box
313 0135	1/2"		1/50



03A MAGNETIC DIRT SEPARATOR FILTERS

"TM-MAG" UNDER-BOILER FILTER

The magnetic dirt separator filter for under-boiler installation **TM-MAG** ensures effective removal of impurities in heating circuits, thanks to the combined double action:

- The neodymium magnet attracts ferrous particles by the action of the magnetic field;
- The filter cartridge mechanically filters the impurities with a particle size of up to 800 µm;
- The large chamber favors the filtration by sedimentation.

TM-MAG can be installed in either vertical or horizontal position, without ever losing efficiency in the protection of the boiler.

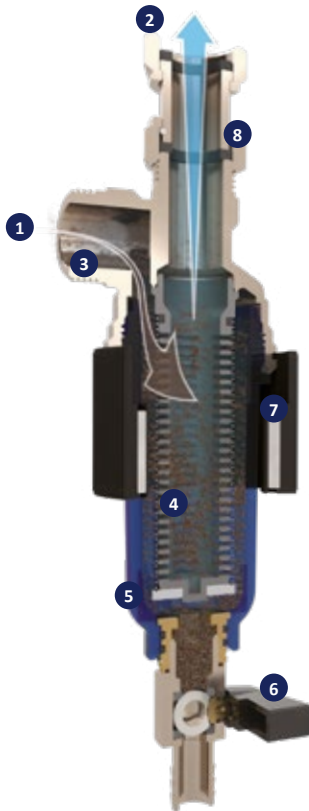
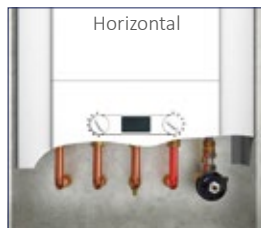
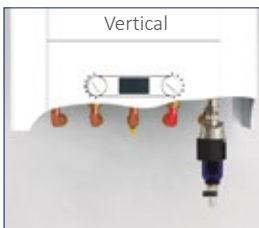

1. System return - fluid to be treated inlet
2. Boiler inlet - treated water filter outlet
3. Shut-off ball valve union
4. Filter cartridge 800 µm.
5. Transparent cup (as in version Art. 3146 and 3147): allows a visual clogging check in the filter.
6. Drain cock.
7. 3 x 12,000 Gauss neodymium magnets. Positioned outside the filtration chamber do not reduce the sedimentation space.
8. Straight connection with loose nut. G 3/4" union for boiler connection.

PRODUCT RANGE



3146

TM-MAG Magnetic dirt separator filter for under-boiler installation with ball valve



TECHNICAL SPECIFICATIONS

- Degree of filtration: 800 µm
- Collection cup material: Polycarbonate
- Body material: Brass CW617N nickel-plated
- Max. operating temperature: 95°C
- Equipped with drain cock

Code	Type	Price €	Unit/Box
315 0003	3/4"		1/8



3147

TM-MAG Magnetic under-boiler dirt separator filter



TECHNICAL SPECIFICATIONS

- Degree of filtration: 800 µm
- Collection cup material: Polycarbonate
- Body material: Brass CW617N nickel-plated
- Max. operating temperature: 95°C
- Equipped with drain cock

Code	Type	Price €	Unit/Box
315 0004	3/4"		1/8



3142

TM-MAG Magnetic dirt separator filter for under-boiler installation with ball valve



TECHNICAL SPECIFICATIONS

- Degree of filtration: 800 µm
- Collection cup material: Brass CW617N nickel-plated
- Body material: Brass CW617N nickel-plated
- Max. operating temperature: 95°C
- Equipped with drain cock

Code	Type	Price €	Unit/Box
315 0030	3/4"		1/8

03A MAGNETIC DIRT SEPARATOR FILTERS

LINEAR FILTERS

The linear magnetic dirt separator filter ensures effective removal of impurities in heating circuits, thanks to the combined double action:

- The neodymium magnet attracts ferrous particles by the action of the magnetic field;
- The filter cartridge mechanically filters the impurities with a particle size of up to 800 µm;
- The large chamber favors the filtration by sedimentation.

Available in a wide range of sizes (up to 1"1/4), finds its application to protect generators with a higher capacity than under-boiler filters (up to 35 kW).

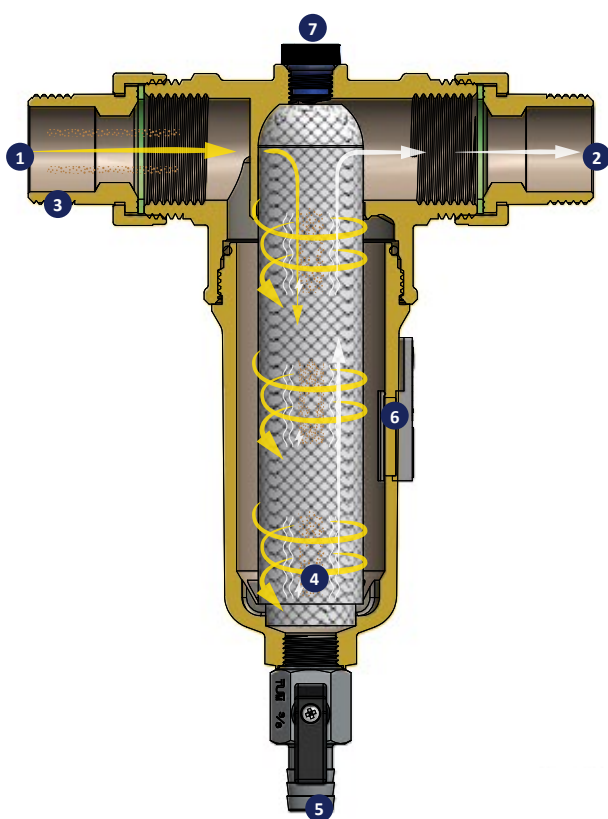

1. System return - fluid to be treated inlet
2. Boiler inlet - treated water filter outlet
3. Union connections: Facilitated installation.
4. Filter cartridge 800 µm.
5. Drain cock.
6. 3 x 12.000 Gauss neodymium magnets. Positioned outside the filtration chamber do not reduce the sedimentation space.
7. G 1/4" connection for pressure gauge or manual exhaust valve.

PRODUCT RANGE



3148

Linear magnetic dirt separator filter with brass cup, male union connections



TECHNICAL SPECIFICATIONS

- Collection cup material: CW617N brass nickel-plated
- Body material: CW617N brass nickel-plated
- Max operating pressure: 10 bar
- Max. operating temperature: 95°C
- Connection threads: ISO 228 male
- Equipped with drain cock

Code	Type	Price €	Unit/Box
315 0005	1/2"		1/14
315 0006	3/4"		1/14
315 0007	1"		1/14
315 0008	1"1/4		1/14



3149

Linear magnetic dirt separator filter with brass cup, male-female connections



TECHNICAL SPECIFICATIONS

- Collection cup material: CW617N brass nickel-plated
- Body material: CW617N brass nickel-plated
- Max operating pressure: 10 bar
- Max. operating temperature: 95°C
- Connection threads: ISO 228 male-female
- Equipped with drain cock

Code	Type F M	Price €	Unit/Box
315 0009	1/2" x 3/4"		1/14
315 0010	3/4" x 1"		1/14
315 0011	1" x 1"1/4		1/14
315 0012	1"1/4 x 1"1/2		1/14



03A MAGNETIC DIRT SEPARATOR FILTERS

SWIVEL FILTER "TM-MAG PLUS"

The **TM-MAG PLUS** swivel magnetic filter combines effective debris separation by cyclonic action with a dual filtration step, first magnetic and then mechanical.

The special inner insert, patented, is designed to direct the flow into a real vortex, so as to favor a first important purification upstream of the powerful magnet and filter cartridge.

TM-MAG PLUS can be installed horizontally, vertically or diagonally thanks to the swivel fitting and locking ring that connect it to the pipe.



Horizontal

Vertical

Diagonally

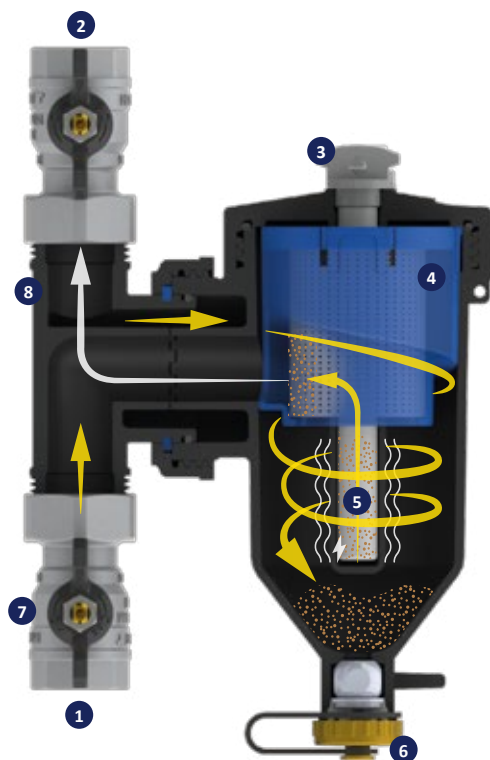

1. System return - fluid to be treated inlet
2. Boiler inlet - treated water filter outlet
3. Manual exhaust valve.
4. Filter cartridge 800 μm (standard filtration). A second 500 μm cartridge is included in the package and can be used in the first filtration step.
5. 14.000 Gauss neodymium detachable magnet
6. Drain cock.
7. Shut-off ball valve.
8. 360° rotating body: allows the filter to be installed in any position, without ever losing efficiency in the filtering action.

PRODUCT RANGE



3141

TM-MAG PLUS Magnetic dirt separator filter



TECHNICAL SPECIFICATIONS

- Degree of filtration: 800 μm
- Body material: PA66 + FV 30%
- Max. operating temperature: 95°C

ADJUSTABLE

Code	Type	Price €	Unit/Box
315 0032	3/4"		1/4
315 0038	1"		1/4

TIEMME **ULISSE** polyphosphates dispenser prevents the formation of scale in the sanitary system and/or in the devices connected to it.

The dispenser must be installed on the supply pipe of the boiler or other equipment (water heater, washing machine, dishwasher), avoiding damage due to scale build-up or corrosion of the internal components.

The polyphosphates dispenser is also useful for repairing the circuits already partly encrusted and subject to corrosion, which are progressively repaired thanks to the action of polyphosphates, optimizing the heat exchange over time. Last but not least, **ULISSE** polyphosphate dispenser is equipped with a 100 µm stainless steel mesh protection filter.

The dosage of polyphosphates tends to eliminate existing limestone deposits over time and creates a thin protective layer on the plant surfaces, also providing an effective corrosion barrier.

Its operating mode uses the vacuum produced by the water passing through the cartridge, allowing the suction of the polyphosphate solution.

The **ULISSE** conformation ensures the correct dosage also with the variable flow of water in compliance with the current regulations.

The cartridge consumption is proportional to the water consumption.

The range is approximately 35-40 m³ (indicative value) and is affected by temperature, frequency of use and frequency of sampling.

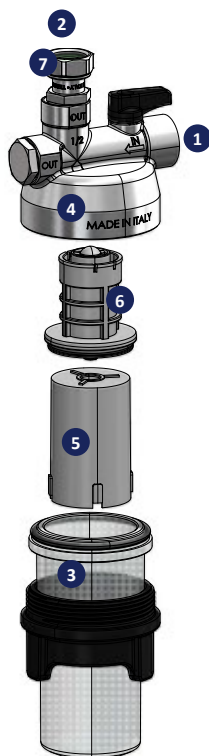

1. Drinking water to be treated inlet
2. Boiler inlet - treated water dispenser outlet
3. Transparent cup
4. Main body in brass
5. Refills of crystal polyphosphates
6. Filter cartridge 100 µm
7. Straight fitting with loose nut.
Union G 1/2" for boiler/device connection.

PRODUCT RANGE

NEW



3155

ULISSE Proportional dispenser of polyphosphates in crystals with shut-off valve and integrated filter supplied with recharge

TECHNICAL SPECIFICATIONS

- Beaker material: PA12
- Body material: Brass CW617N chrome plated
- Maximum working pressure: 8 bar
- Max operating temperature: 30°C
- Cartridge Life: ~ 30÷40 m³
- Performance: 100 µm
- Connection threads: ISO 228

Code	Type	Price €	Unit/Box
310 0001	1/2"		1/6

NEW



3155POL

Polyphosphate refill in crystals for proportional dispenser (2 bags)

Code	Type	Price €	Unit/Box
310 0003	for art. 3155		1/10

NEW



3157KIT

2 pieces kit: Under-boiler magnetic dirt separator filter **TM-MAG EVO** and Proportional dispenser of polyphosphates **ULISSE**

TECHNICAL SPECIFICATIONS

MAGNETIC DIRT SEPARATOR FILTER

- see technical characteristics art. 3154

POLYPHOSPHATES DISPENSER

- see technical characteristics art. 3155

Code	Type	Price €	Unit/Box
315 0075	-		1/1



TM-NEUTRIX is the TIEMME acid condensate neutralizer for condensation boilers.

Condensation boilers are widely used for their simple installation, combined with high efficiency largely resulting from the recovering the energy contained in the combustion fumes, making them condense before they get expelled. However, this condensate is extremely acidic and dangerous for the pipes and the environment: The solution is to neutralize it upstream of the drain.

Despite the reference standard for the discharge of condensates (UNI 7129-5) does not provide for chemical treatment for boilers with a capacity of less than 35 kW, the continuous contact with the acid condensate can quickly seriously damage the metal parts that constitute the discharge line.

With the installation of **TM-NEUTRIX** downstream of the boiler, the condensate flows into a neutralizing charge of calcium carbonate which raises the pH of the fluid, allowing it to be safely discharged.

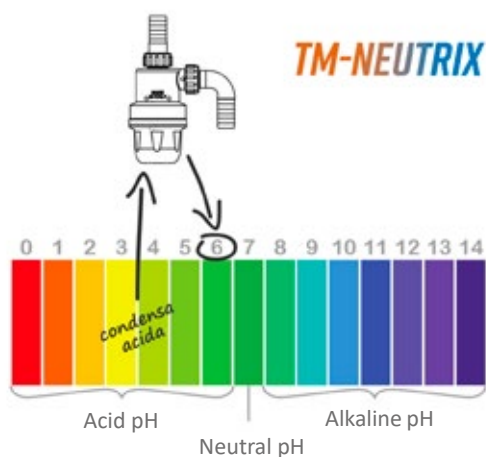

PRODUCT RANGE

NEW



3156

TM-NEUTRIX Acid condensate neutralizer filter supplied with refill (2 bags)

TECHNICAL SPECIFICATIONS

- Beaker material: Transparent PA
- Body material: PA-GF
- Max operating temperature: 50°C
- Equipped with wall fixing collar

Code	Type	Price €	Unit/Box
309 0003	Ø 16		1/6
309 0004	Ø 20		1/6

NEW



3156CAR

Calcium Carbonate Refill (6 bags) for acid condensate neutralizer filter

TECHNICAL SPECIFICATIONS

- Material: CaCO₃

Code	Type	Price €	Unit/Box
309 0006	for art. 3156		1/6

The presence of air in the systems is a common occurrence that requires particular measures in order to ensure a correct operation. The air that is not properly removed may cause different problems:

NOISE IN PIPES, TERMINALS AND VALVES:

The noise in the pipes occurs especially during the starting phase of the system, when the air introduced during the filling operation has not yet reached the deaerators. The noise of the valves is, on the other hand, closely linked to the presence of air microbubbles which, passing through the regulating members, undergo a sudden pressure reduction which causes the phenomenon of cavitation. These air microbubbles are spheres of dimensions ranging from 0,02 to 0,10 mm, can be formed on the separation surfaces between water and the combustion chamber of the generator (microbubbles of the generator), or where the threads of the fluid reach very high speeds, for example, in the vicinity of bottlenecks in the system or circulation pump impellers (cavitation microbubbles).

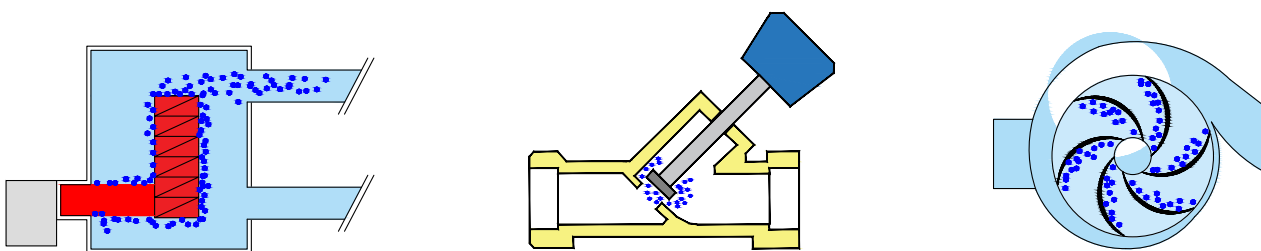

BLOCKING OF THE CARRIER FLUID CIRCULATION OR INSUFFICIENT FLOW RATES AT THE EMISSION TERMINALS:

The air that adds up in the system may cause the circulation pumps to malfunction, which cannot transfer energy to an incompressible fluid such as water, but to a water-air mixture that loses its properties.

The air also occupies volume at the expense of the carrier fluid, both in the pipes and in the emission terminals, causing bottlenecks and overpressures, consequently causing a decrease in the yield.

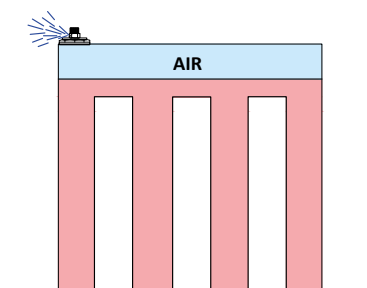

CORROSIVE PHENOMENA OF METAL COMPONENTS:

The oxygen in the air can trigger corrosive phenomena of ferrous materials, according to the following chemical formula



03_D AUTOMATIC AIR VENT VALVES

HIGH PERFORMANCE

This series of valves is characterized by their high air vent capacity and is equipped with a protective cap against sudden hot fluid spills.

The air in the system reduces the water level in the vent valve, which lowers the float and opens the gas ejection device. Otherwise, if there is no air in the system, the water inside the vent valve keeps the float in such a position as to close the gas ejection device.

Cap with air vent hole:
provides protection
against sudden hot
fluid spills.

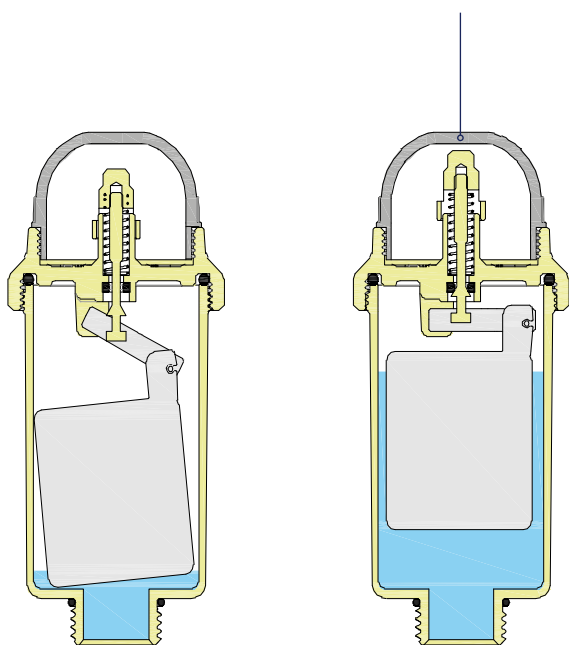

OPEN position

CLOSED position

PRODUCT RANGE



1896

Nickel-plated automatic air vent valves

TECHNICAL SPECIFICATIONS

- Max. operating temperature: 110°C
- Maximum operating pressure: 16 bar
- Maximum discharge pressure: 4 bar
- Threads: UNI ISO 228 male
- Used fluids: water and glycol solution
- Maximum glycol percentage: 30%

Code	Type	Price €	Unit/Box
198 0068	1/2"		1/20
198 0074	3/4"		1/20

Male connection with O-ring seal

ACCESSORIES AND SPARE PARTS



1896GG

Float unit for automatic air vent valves art. 1896

Code	Type	Price €	Unit/Box
198 0070	-		1/20

This series of valves is characterized by their compact size and by being fitted with a closure cap for the air ejection device. The gas expulsion device guarantees excellent performance and has been designed in such a way as to prevent any impurities present in the water from dirtying the sealing seats, causing water to leak from the valve.

The air in the system reduces the water level in the vent valve, which lowers the float and opens the gas ejection device. Otherwise, if there is no air in the system, the water inside the vent valve keeps the float in such a position as to close the gas ejection device.

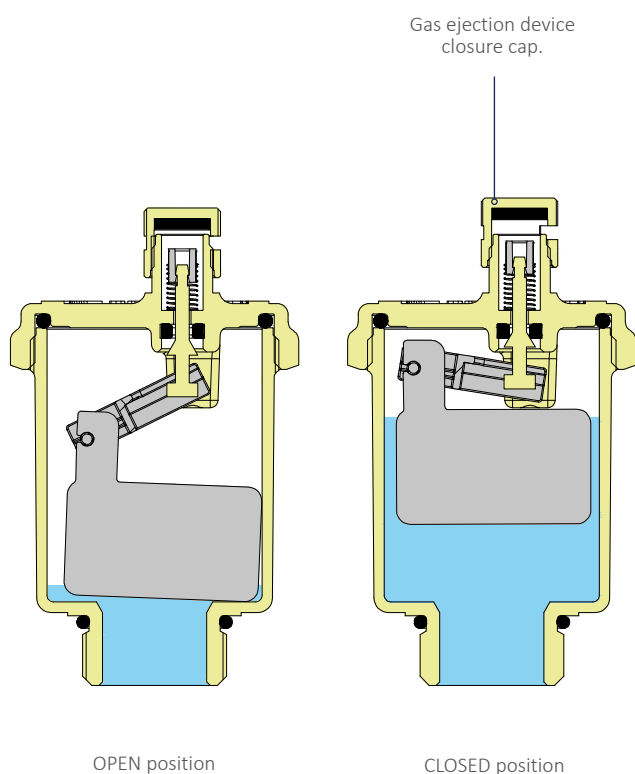

PRODUCT RANGE



1914

Automatic air vent valves nickel-plated with side connection

TECHNICAL SPECIFICATIONS

- Max. operating temperature: 110°C
- Maximum operating pressure: 10 bar
- Maximum discharge pressure: 4 bar
- Threads: UNI ISO 228 male
- Used fluids: water and glycol solution
- Maximum glycol percentage: 30%

Code	Type	Ø	Price €	Unit/Box
198 0126	3/8"	39		1/50
198 0127	1/2"	39		1/50



1913

Automatic air vent valves nickel-plated

TECHNICAL SPECIFICATIONS

- Max. operating temperature: 110°C
- Maximum operating pressure: 10 bar
- Maximum discharge pressure: 4 bar
- Threads: UNI ISO 228 male
- Used fluids: water and glycol solution
- Maximum glycol percentage: 30%

Code	Type	Ø	Price €	Unit/Box
198 0128	3/8"	39		1/50
198 0129	1/2"	39		1/50



1913G

Automatic air vent valves

TECHNICAL SPECIFICATIONS

- Max. operating temperature: 110°C
- Maximum operating pressure: 10 bar
- Maximum discharge pressure: 4 bar
- Threads: UNI ISO 228 male
- Used fluids: water and glycol solution
- Maximum glycol percentage: 30%

Code	Type	Ø	Price €	Unit/Box
198 0130	3/8"	39		1/50
198 0131	1/2"	39		1/50



03_D AUTOMATIC AIR VENT VALVES

COMPACT

This series of valves is characterized by their compact size and by being fitted with a closure cap for the air ejection device.

The air in the system reduces the water level in the vent valve, which lowers the float and opens the gas ejection device. Otherwise, if there is no air in the system, the water inside the vent valve keeps the float in such a position as to close the gas ejection device.

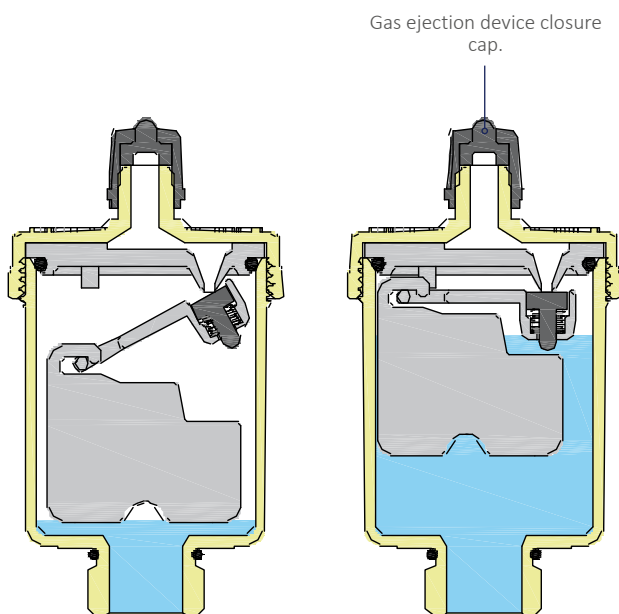

OPEN position

CLOSED position



1898

Automatic air vent valves (side vent)

Code	Type	Ø	Price €	Unit/Box
198 0005	3/8"	39		1/50
198 0004	1/2"	39		1/50



1898G34

Automatic air vent valve with body Ø34 mm (side vent)

Code	Type	Ø	Price €	Unit/Box
198 0114	3/8"	34		1/70
198 0092	1/2"	34		1/70

NEW



1898KIT34

Kit automatic air vent valve with body Ø34 mm (purge on side) + cut-off valve

Code	Type	Ø	Price €	Unit/Box
198 0112	3/8"	34		1/70
198 0113	1/2"	34		1/70



1899

Automatic air vent valves with side connection

Code	Type	Ø	Price €	Unit/Box
198 0011	3/8"	39		1/50
198 0003	1/2"	39		1/50



1900

Automatic air vent valve

Code	Type	Ø	Price €	Unit/Box
198 0002	3/8"	39		1/50
198 0001	1/2"	39		1/50
198 0013	3/4"	45.5		1/25
198 0022	1"	45.5		1/25

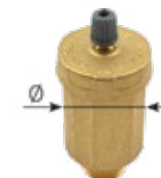

1900G

Automatic air vent valve

Code	Type	Ø	Price €	Unit/Box
198 0014	3/8"	39		1/50
198 0007	1/2"	39		1/50

Air vent valves with a small diameter art. **1900N34** and **1900G34** find their application in riser columns with narrow center distance (**distance between pipes min. 34 mm**), where other valves would not be used due to the larger overall dimensions.

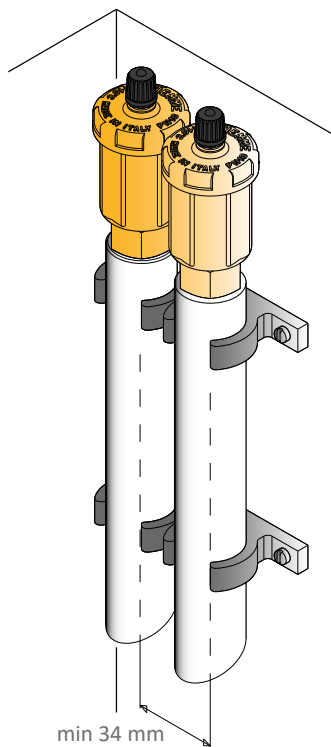

PRODUCT RANGE



1900N34
Automatic air vent valve with body Ø 34 mm

Code	Type	Ø	Price €	Unit/Box
198 0024	3/8"	34		1/40
198 0029	1/2"	34		1/40



1900G34
Automatic air vent valve with body Ø 34 mm

Code	Type	Ø	Price €	Unit/Box
198 0017	3/8"	34		1/40
198 0019	1/2"	34		1/40

PRODUCT RANGE



5570
Automatic bubble or microbubbles deaerator with insulation.

TECHNICAL SPECIFICATIONS

- Body: Brass
- Internal elements: Stainless steel
- Insulation: EPP
- Operating temperature range: - 10 °C ÷ + 120 °C
- Maximum operating pressure: 10 bar

Code	Type	Price €	Unit/Box
556 0001	3/4"		1/1
556 0002	1"		1/3
556 0003	1"1/4		1/3
556 0004	1"1/2		1/3
556 0395	2"		1/3

Without insulation



1. Gas ejection device: in the event of a possible leak from the deaerator, the deaerator can be closed by means of a screw.
2. Conical accumulation chamber equipped with extended float to increase the distance from the vent valve: minimizes the possibility of contamination of the valve seat.
3. Float.
4. Protection plate.
5. Steel rings: they promote the discharge of microbubbles, thanks to their large contact surfaces.
6. Brass Body





3350
Air vent valve for radiators

Code	Type	Price €	Unit/Box
198 0021	1/8"		10/500
198 0020	1/4"		10/500
198 0015	3/8"		10/500
198 0016	1/2"		10/500



3351
Air vent valve for radiators with PTFE sealing

Code	Type	Price €	Unit/Box
198 0010	1/4"		10/500
198 0008	3/8"		10/500
198 0006	1/2"		10/500



3352
Air vent valve for radiators with screwdriver cut

Code	Type	Price €	Unit/Box
198 0049	1/4"		10/500
198 0047	3/8"		10/500
198 0018	1/2"		10/500



1901
Cut-off valve with o-ring sealing and brass shutter

Code	Type	Price €	Unit/Box
198 0012	3/8"		10/300
198 0009	1/2"		10/100
198 0023	M 1/2" - F 3/8"		10/300



1901P
Cut-off valve with o-ring sealing and plastic shutter

Code	Type	Price €	Unit/Box
198 0106	3/8"		10/300
198 0108	1/2"		10/300
198 0110	M 1/2" - F 3/8"		10/300



1901PN
Nickel plated cut-off valve with o-ring sealing and plastic shutter

Code	Type	Price €	Unit/Box
198 0107	3/8"		10/300
198 0109	1/2"		10/300
198 0111	M 1/2" - F 3/8"		10/300

04

ADJUSTMENT AND MANAGEMENT DEVICES

04A Hydronic units

Hydronic unit for HP - DHW management



74

Hydronic unit for double source management



75

04B Motorized ball valves

2/3-way ball valves



76

6-way ball valves



78

04C Thermostatic diverter/mixing valve



79

04D Anti-condensation valve



84

04E Differential by-pass valve



86

The Hydronic unit art. 5532PDC is used in systems where the heat pump (HP) is the only generator available for heating/cooling of rooms and for the production of domestic hot water (DHW). The 3-way valve diverts flow according to system demand. The presence of the differential by-pass prevents possible interruption of the flow in the HP. The Hydronic unit art. 5532PDC is extremely versatile and compact, to be used for the connection of any type of HP without brand and model constraints, ensuring the correct management of the heating and DHW production system. The diverter can be managed through the HP regulator or the power station or through the Tiemme Climav 2.0 Building Management thermoregulation, which provides a special slave module SACS art.5530S3 that allows the management of the DHW accumulation sub-system. The heat-molded shell insulation prevents condensation from forming on the surface of the device and makes it possible to use the kit also for cooling systems. Moreover, this system ensures not only perfect thermal insulation but also hermetic transmission of water vapor from the environment into the room.

ADVANTAGES / STRENGTHS

- Super compact;
- Complete with differential by-pass;
- Provided with insulating shell;
- 1" diverter valve;
- Universal.

TIEMME INFORMS

The servocontrol operates on the valve with a 180° one-way rotation. The valve can be operated manually, after removing the servocontrol, by acting on the control pin with an 8 mm open-end wrench; the milled surface of the pin corresponds to the lateral opening hole of the ball. The diverter valve performs the function of interception and deviation, allowing the fluid to enter from below (third way) conveying it to the right or left, or vice versa from right or left to the third way.

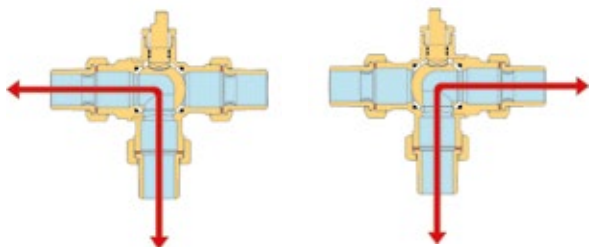

5532PDC

Hydronic unit for HP - DHW management

TECHNICAL SPECIFICATIONS

- 3-way diverter ball valve with 1" union connections:
 - Heat transfer fluid temperature from 0°C to 100°C.
 - PN16 operating pressure
 - Maximum differential pressure 10 bar
 - Power supply terminals 1 - 4 to 230 Vac
 - Power consumption 6 VA
 - Terminal 2-3 relay contact clean (not live) active with valve open
 - Protection rating IP44
 - Operating temperature min -5°C max 55°C
 - Maximum rotational torque 8 Nm
 - Maneuvering time 80 sec.
 - Fuse 5x20 F350 mA
- Differential by-pass with regulation 50-400 mbar
- Insulation shell in PE-x closed cell foam

Code	Type	Price €	Unit/Box
556 0272	1"		1/1

5532PDC INSTALLATION EXAMPLE

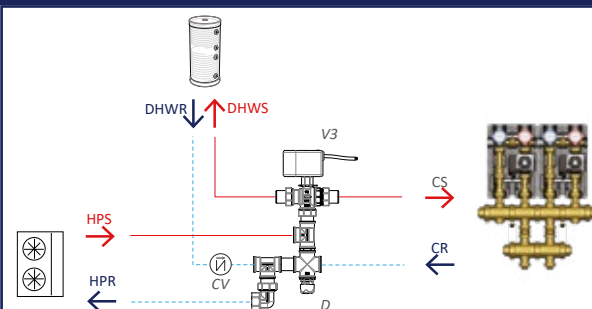

KEY

- CS: consumer supply
- CR: consumer return
- DHWS: domestic hot water supply
- DHWR: domestic hot water return
- HPS: heat pump supply
- HPR: heat pump return
- V3: motorized 3-way valve
- CV: check valve
- D: differential by-pass

PRESSURE DROP DIAGRAM

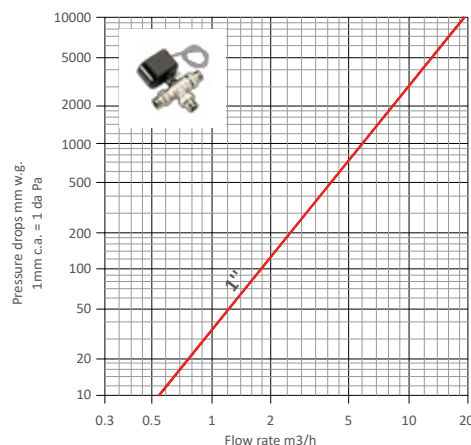

For pricelist scan the QR code

The hydronic unit art. 5532HYBRID is used in systems with at least two distinct generators, typically hybrid systems with heat pump (HP) and boiler. Regarding the automatic switching from one generator to another, the 3-way valve allows the carrier fluid to pass through the selected system. The differential by-pass prevents possible interruptions of the fluid flow in the system so as to avoid possible blockages due to the lack of minimum flow to the generator. The hydronic unit art. 5532HYBRID, extremely versatile and employable for different energy sources, is suitable both in new system solutions, which provide for the supply of energy from different sources, and in the restructuring of the heating systems if switching to a hybrid system in a simple way is what we want. The diverter can be managed through the heat pump or power station regulator or through the Tiemme Climav 2.0 Building Management thermoregulation, which provides a special Slave module art. 5530S5 that allows the management of up to 3 thermal/refrigerator generators with operating priority. The heat-molded shell insulation prevents condensation from forming on the surface of the device and makes it possible to use the kit also for cooling systems. Moreover, this system ensures not only perfect thermal insulation but also hermetic transmission of water vapor from the environment into the room.

ADVANTAGES / STRENGTHS

- Super compact;
- Complete with differential by-pass;
- Provided with insulating shell;
- 1" diverter valve;
- Universal.

TIEMME INFORMS

The servocontrol operates on the valve with a 180° one-way rotation. The valve can be operated manually, after removing the servocontrol, by acting on the control pin with an 8 mm open-end wrench; the milled surface of the pin corresponds to the lateral opening hole of the ball. The diverter valve performs the function of interception and deviation, allowing the fluid to enter from below (third way) conveying it to the right or left, or vice versa from right or left to the third way.

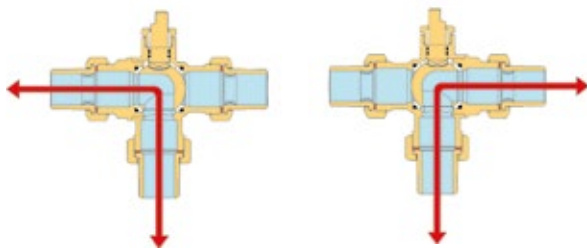

5532HYBRID
Hydronic unit for double source management

TECHNICAL SPECIFICATIONS

- 3-way diverter ball valve with 1" union connections:
 - Heat transfer fluid temperature from 0°C to 100°C.
 - PN16 operating pressure
 - Maximum differential pressure 10 bar
 - Power supply terminals 1 - 4 to 230 Vac
 - Power consumption 6 VA
 - Terminal 2-3 relay contact clean (not live) active with valve open
 - Protection rating IP44
 - Operating temperature min -5°C max 55°C
 - Maximum rotational torque 8 Nm
 - Maneuvering time 80 sec.
 - Fuse 5x20 F350 mA
- Differential by-pass with regulation 50-400 mbar
- Insulation shell in PE-x closed cell foam

Code	Type	Price €	Unit/Box
556 0273	1"		1/1

5532HYBRID INSTALLATION EXAMPLE

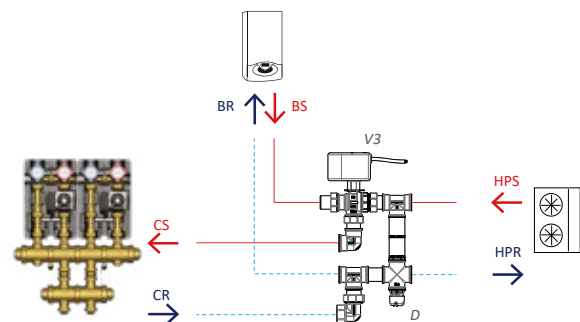

KEY

BS:	boiler supply
BR:	boiler return
CS:	consumer supply
CR:	consumer return
HPS:	heat pump supply
HPR:	heat pump return
V3:	motorized 3-way valve
D:	differential by-pass

PRESSURE DROP DIAGRAM

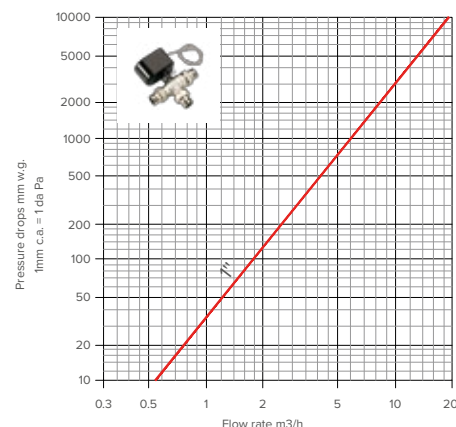



2139

2-way motorized ball valve, full port, female/female, for actuators with ISO5211

Code	Type	Price €	Unit/Box
213 0104	1/2"		15/60
213 0107	3/4"		10/40
213 0108	1"		7/28



2138

2-way motorized ball valve male/female with servocontrol

i Also available with a 24Vac power supply

Code	Type	Power	Price €	Unit/Box
213 0020	1/2"	230 Vac		1/14
213 0003	3/4"	230 Vac		1/14
213 0007	1"	230 Vac		1/14
213 0019	1"1/4	230 Vac		1/14



2133

2-way motorized ball valve male/male with servocontrol

i Also available with a 24Vac power supply

Code	Type	Power	Price €	Unit/Box
213 0011	3/4"	230 Vac		1/14
213 0016	1"	230 Vac		1/14



9535

Servomotor for 2-ways valve (art. 2138 - 2133); 90° one-way rotation, supplied with protection fuse. Case with protection rating IP44

Code	Voltage	Time	Price €	Unit/Box
213 0024	230 Vac	40 sec		1/8
213 0072	24 Vac	40 sec		1/8



2134

3-way diverter motorized ball valve - 3-union connections - with servomotor.

i Also available with a 24Vac power supply

Code	Type	Power	Price €	Unit/Box
213 0009	3/4"	230 Vac		1/4
213 0018	1"	230 Vac		1/4



9537

Servomotor for diverter motorized valves (for articles 2134); 180° one-way rotation, supplied with protection fuse. Case with protection rating IP44

Code	Voltage	Time	Price €	Unit/Box
213 0025	230 Vac	80 sec		1/8
213 0031	24 Vac	80 sec		1/8



2137

3-way motorized ball valve with bypass - 3-union connections - with servomotor.

i Also available with a 24Vac power supply

Code	Type	Power	Price €	Unit/Box
213 0021	3/4"	230 Vac		1/4
213 0015	1"	230 Vac		1/4



2136

3-way motorized ball valve with bypass - 4-union connections - with servomotor. Variable distance between centers (50-63mm for 3/4" valves; 55-63mm for 1" valves)

i Also available with a 24Vac power supply

Code	Type	Power	Price €	Unit/Box
213 0013	3/4"	230 Vac		1/4
213 0028	1"	230 Vac		1/4





9536

Servomotor for by-pass zonevalve (art. 2136-2137); 90° bidirectional rotation, supplied with protection fuse. Case with protection rating IP44

Code	Voltage	Time	Price €	Unit/Box
213 0030	230 Vac	40 sec		1/8
213 0037	24 Vac	40 sec		1/8

VIDEO TUTORIALS



Motorized ball valves - Operation principles



Motorized Ball Valves - Electrical connections

2138 - 2133

TECHNICAL SPECIFICATIONS

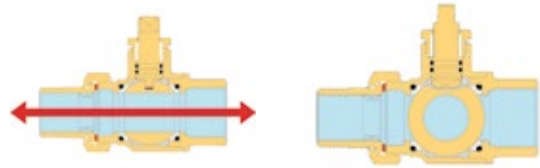

- 230 Vac or 24 Vac power supply
- Relay contact 6A 250 Vac
- Protection rating IP 44
- Max rotational torque 8 Nm
- Rotation time 40 sec.
- Fuse 5x20 F350 mA

2134

TECHNICAL SPECIFICATIONS

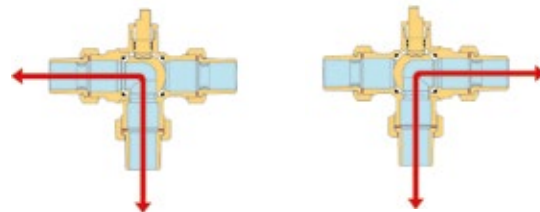

- 230 Vac or 24 Vac power supply
- Relay contact 6A 250 Vac
- Protection rating IP 44
- Max rotational torque 8 Nm
- Rotation time 80 sec.
- Fuse 5x20 F350 mA.

2137

TECHNICAL SPECIFICATIONS

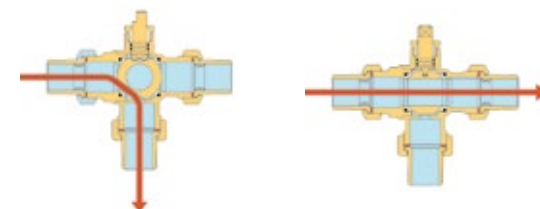

- 230 Vac or 24 Vac power supply
- Relay contact 6A 250 Vac
- Protection rating IP44
- Max rotational torque 8 Nm
- Rotation time 40 sec.
- Fuse 5x20 F350 mA

2136

TECHNICAL SPECIFICATIONS

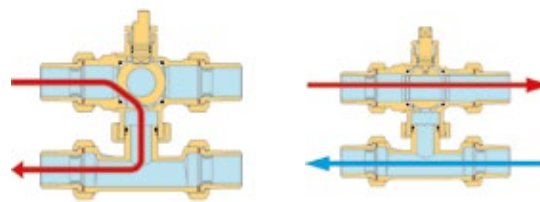

- 230 Vac or 24 Vac power supply
- Relay contact 6A 250 Vac
- Protection rating IP44
- Max rotational torque 8 Nm
- Rotation time 40 sec.
- Fuse 5x20 F350 mA

04_B 6-WAY BALL VALVE

The 6-way ball valve art. 2130SM allows to manage in a synchronized way the 4 tubes of two different sources of the system (heating and cooling).

It finds application in 4-tube systems for heating/cooling management, with a single terminal (fan coil, radiant ceilings).

PRODUCT RANGE



2130SM

Motorized 6-way ball valve for heating/cooling management

Supplied with washer kit for flow adjustment

Code	Type	Price €	Unit/Box
213 0129	3/4"		1/8

2130SM

OPERATION

HEATING SYSTEM SWITCHING

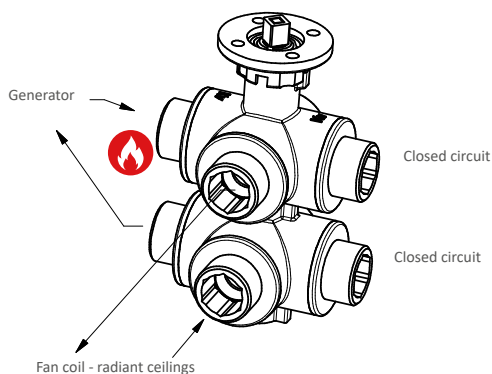

COOLING SYSTEM SWITCHING

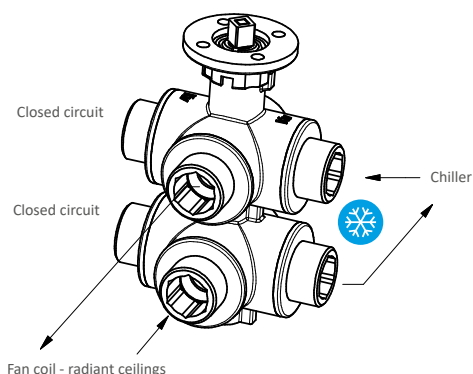

The rotation of the two "L" balls, operated by a rotary servo controller, allows to enable one section of the system to return (e.g. cooling) and simultaneously disable the other section of the system (e.g. heating).

Thus, it is possible to switch the summer/winter system management automatically, avoiding the mixing between the flows coming from the two different circuits.

ACCESSORIES AND SPARE PARTS



9538

Servomotor for ball valve (art. 2130SM); 90° bidirectional rotation. Case with protection rating IP50

Code	Type	Price €	Unit/Box
213 0132	24 Vac		1/8



2130STAF

Support bracket

Code	Type	Price €	Unit/Box
213 0136	-		1/20



2130KIT

Tang kit (6 pcs)

Code	Type	Price €	Unit/Box
213 0141	3/4" - 1/2"		1/5
213 0142	3/4" - 3/4"		1/5



2130ISOL

Insulation shell

Code	Type	Price €	Unit/Box
213 0139	3/4"		1/50



2130DIM

Washers kit calibrated with different Kv for flow rate adjustment

Code	Type	Price €	Unit/Box
213 0134	-		1/50



04c THERMOSTATIC DIVERTER/MIXING VALVE

Tiemme 3-way valve art. 38.90VD for mixing/diverting flow rates in heating and cooling systems. It carries out a constant proportional adjustment needing no electrical connections, thanks to the use of thermostatic heads with contact or immersion probe. Double function as diverter or mixer.

ADVANTAGES / STRENGTHS

- Super compact;
- Double function as thermostatic diverter/mixer;
- No electrical connection required;
- Multifunction depending on the wiring diagram.

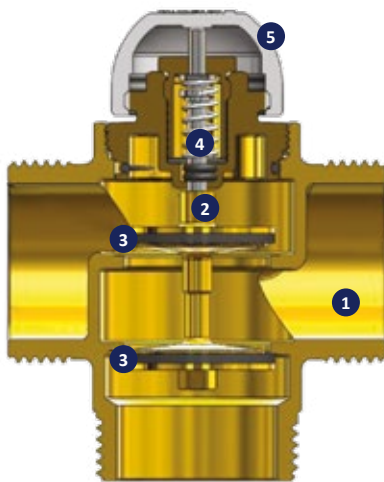

1. Brass body
2. Brass stem
3. Seals
4. Spring
5. Cap

PRESSURE DROP DIAGRAM

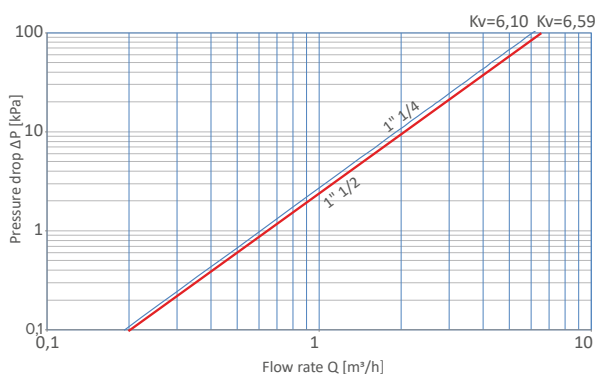

INSTALLATION EXAMPLES

3890VD

PLANT SOLUTION 1: DIVERTER FUNCTION

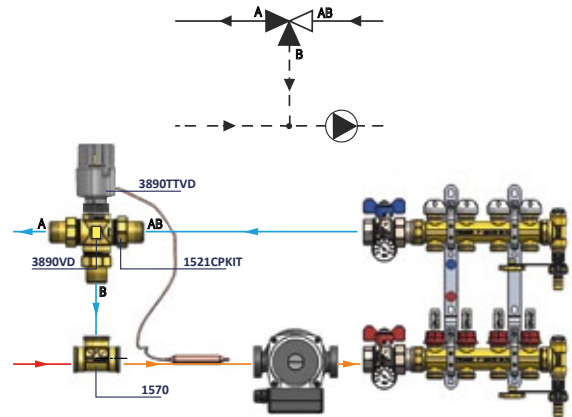

Working as a 3-way diverter valve for floor heating system management: once the regulating temperature has been set by rotating the thermostatic head, when the temperature increases, the straight direction of flow is closed while the angular direction is open. As the temperature decreases, the straight direction of flow opens while the angular direction closes. This valve can be used to divert the return water flow from the floor heating system to the boiler. This will always ensure the set temperature for the fluid entering the system.

3890VD

PLANT SOLUTION 2: MIXER FUNCTION

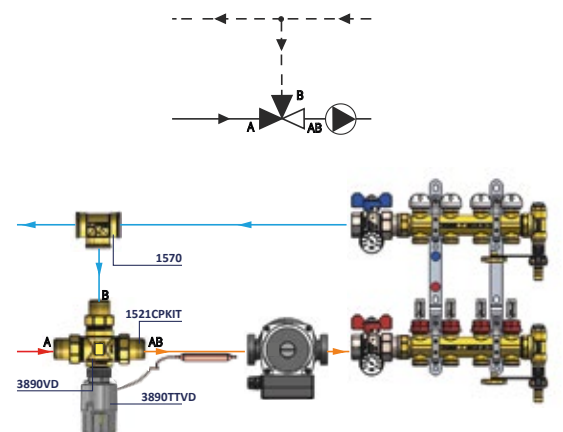

Working as a 3-way mixing valve for control of the floor heating system: once the regulating temperature has been set by rotating the thermostatic head, the constant mixing of the return flow from the circuit with the one from the boiler causes the delivery temperature to be maintained at the desired value.

3890VD

PLANT SOLUTION 3:
MIXER FUNCTION

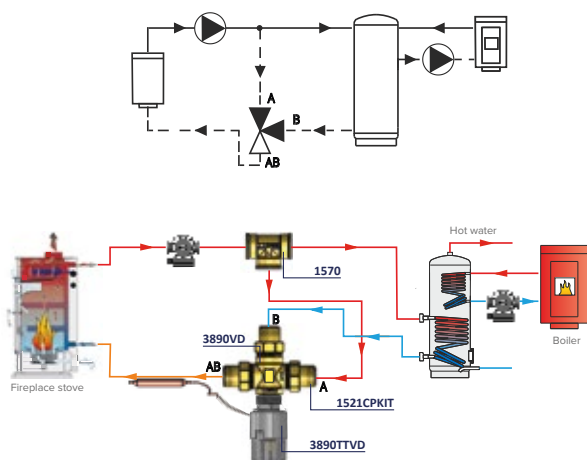

Control of the return temperature in circuits with heating fireplace: working as a 3-way mixing valve, once the regulation temperature has been set by rotating the thermostatic head, the valve does not cause the return temperature to drop below the preset value (anti-condensation), as the temperature of the return fluid from the system rises, the valve adapts to increase the flow of the system and vice versa.

3890VD

PLANT SOLUTION 4:
DIVERTER FUNCTION

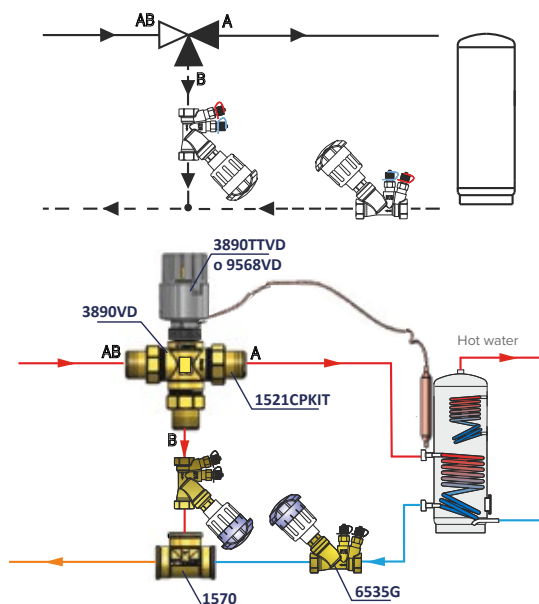

Control of the temperature of the heat exchanger for the production of DHW: in such a way the temperature is controlled according to the temperature detected by the temperature probe placed in the exchanger.

3890VD

PLANT SOLUTION 5:
DIVERTER / MIXER

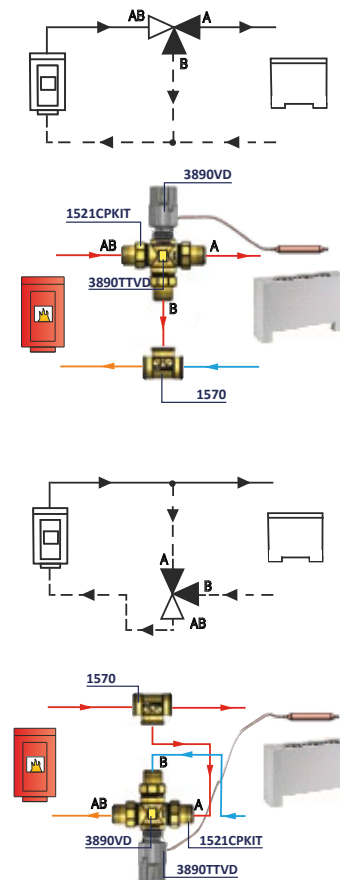

Control of the temperature at the outlet of the fan coils: the valves are used to divert/mix the thermal carrier fluid of a heating or air conditioning system according to what is detected by the temperature probe as a function of the temperature set by means of a knob. In this case, the valve can be used indifferently as a diverter or mixer, meeting the various hydraulic assembly requirements.



PRODUCT RANGE



3890VD

3-way thermostatic diverter/mixing valve for heating and cooling systems management. According to the direction, it works either as diverter or mixing valve.

TECHNICAL SPECIFICATIONS

- Max operating temperature: 100 °C
- Max operating temperature: -15 °C
- Max operating pressure: 10 bar
- Liquids to be used: Water (glycol < 50%)
- Threads: ISO 228 with flat stop
- Shutter stroke: 2.5 mm
- Actuator union: M30 x 1.5
- Body material: Brass CW617N
- Stem material: Brass CW617N
- Spring material: Stainless steel

Code	Type	Price €	Unit/Box
450 0047	1"		2/20
450 0515	1" 1/4		1/10
450 0516	1" 1/2		1/10

ACCESSORIES AND SPARE PARTS



1521CPKIT

Union kit

i The kit includes: 3 tails, 3 nuts and 3 gaskets

Code	Type	Price €	Unit/Box
150 1017	1" F x 3/4" M		1/20
150 1013	1" 1/4 F x 1" M		1/15
150 1014	1" 1/2 F x 1" 1/4 M		1/10



1570

T female

Code	Type	Price €	Unit/Box
150 0009	3/4" x 3/4" x 3/4"		5/50
150 0005	1" x 1" x 1"		5/25
150 0029	1" 1/4 x 1" 1/4 x 1" 1/4		5/25



3890TTVD

Thermostatic head with remote probe for diverter/mixing valve

Code	Type	Price €	Unit/Box
450 0527	20 - 50°C		1/10
450 0556	40 - 70°C		1/10



9568VD

Electrothermal actuator for 3-way thermostatic diverter/mixing valve (art. 3890VD)

i ON/OFF operation.

i Valve position normally closed if no voltage is present

+ Supplied with "FIRST OPENING" function: facilitates first installation on the manifold. See the datasheet for details.

Code	Type	Price €	Unit/Box
450 0666	24V		1/20
450 0664	230V		1/20
450 0667	24V		1/20
450 0665	230V		1/20

Version with auxiliary microswitch



9562P

0÷10V Proportional servocontrol for 3-way mixing valves

i To be combined with the RC_SA thermoregulation system art. 5530M5 - 5530M6 shown on the following pages.

Code	Type	Price €	Unit/Box
450 0463	0÷10V - 24Vac		1/10

RC_SA - CLIMATE CONTROL



5530M5 5530M6

RC_SA climate control allows to control fluid medium temperature in heating and climate regulation systems, by controlling a mixing valve with proportional or 3-point servomotor.

DESCRIPTION

The control enables the following management modes of fluid medium temperature:

- climate compensation by installing an external probe;
- climate compensation by installing an external and a room probe;
- compensation by analyzing system return temperature (only in heating mode).

Depending on connected devices, it is possible to control one or two different thermal zones and switch any neutral air dehumidifier on.

TECHNICAL SPECIFICATIONS

- Power supply: 85 ÷ 230 Vac 50/60 Hz or 24 Vac
- Consumption: 5 W
- Protection fuse: 1 A
- Graphic display: 1.8" color
- Size: no. 6 modules to be installed on DIN bar
- Keyboard programming: 7-key board
- Inlets:
 - Combined thermostat inlet;
 - Inlet for remote summer-winter switching
 - ON/OFF remote inlet
 - Climav 2.0 Building Management system room probe
 - 5530 external probe
 - 5530P inflow probe
 - 5530P return probe
- Outgoes:
 - 1 ON/OFF contact to switch the pump on
 - 1 ON/OFF contact to control the dehumidifier
 - 1 ON/OFF contact to switch the thermal zone on
 - 0-10 V to control proportional servomotor
 - 2 ON/OFF contacts to control 3-point servomotor
- Size (LxHxP): 105 x 95 x 60 mm (6 DIN modules)

For system climate regulation

Code	Power supply	Price €	Unit/Box
art. 5530M5			
555 0302	85-230 Vac		1/4
art. 5530M6			
555 0304	24 Vac		1/4

T_EXT



5530E

Temperature and humidity external probe

Used in Climav 2.0 Building Management thermoregulation system to compensate in climate regulation.

TECHNICAL SPECIFICATIONS

- Resistance: 10Kohm at 25 °C
- Protection class: II
- Shell: Plastic ABS
- Installation: on the wall
- Protection category: IP54
- Measuring range: -40 ÷ +110 °C
- External environmental temperature: 15 ÷ 55 °C
- External relative humidity: up to 85 % at T=25 °C
- Storage temperature: 0 ÷ 60 °C
- Relative storage humidity: no condensation
- Size: 74 x 109 x 59 mm

Code	Type	Price €	Unit/Box
555 0145	-		1/4

5530P

NTC 10KΩ @ 25°C, 6 mm diameter temperature probe



Code	Type	Price €	Unit/Box
555 0149	-		1/10



04c THERMOSTATIC DIVERTER/MIXING VALVE

THERMOREGULATION

T_G



5530E2
Wall installation temperature environmental probe

TECHNICAL SPECIFICATIONS
• Size (LxHxP): 120 x 80 x 20 mm

i To be placed in each room and connected to Climav 2.0 Building Management system.

Code	Color	Price €	Unit/Box
555 0140	□ White		1/4
555 0342	■ Black		1/4

TH_G



5530E1
Wall installation temperature/humidity environmental probe

TECHNICAL SPECIFICATIONS
• Size (LxHxP): 120 x 80 x 20 mm

i To be placed in each room and connected to Climav 2.0 Building Management system.

Code	Color	Price €	Unit/Box
555 0139	□ White		1/4
555 0340	■ Black		1/4

T_P

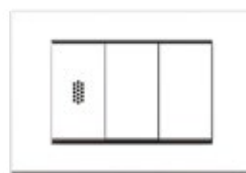

5530I9
In-built temperature environmental probe.

i To be placed in 503 box. Signal the civil series employed (e.g., Vimar Idea, Piana, Bticino Light, Light Tech, etc.) to Tiemme's technician, so as to match the house's aesthetic features.

i To be placed in each room and connected to Climav 2.0 Building Management system.

Code	Civil line	Price €	Unit/Box
555 0327	upon request		1/40

TH_P

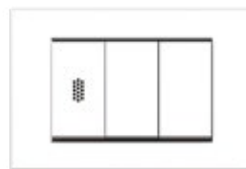

5530I10
In-built temperature/humidity environmental probe.

i To be placed in 503 box. Signal the civil series employed (e.g., Vimar Idea, Piana, Bticino Light, Light Tech, etc.) to Tiemme's technician, so as to match the house's aesthetic features.

i To be placed in each room and connected to Climav 2.0 Building Management system.

Code	Civil line	Price €	Unit/Box
555 0329	upon request		1/40



Anti-condensation valve art. 4732 is used to protect the generator from the temperature of the return heat transfer fluid which is too low, thus preventing the appearance of condensation of the vapor contained in the fumes.

The Tiemme valve independently regulates the temperature of the water returning from the storage to the solid fuel heat generator (wood boilers, pellets...), ensuring a stable return temperature at high values, **with consequent benefits on the longer life and efficiency of the generator.**

The regulation of the temperature at the generator inlet is carried out by the thermostatic element, which, in contact with the water, undergoes a variation of the volume determining the correct supply of water to both inlets to the valve with subsequent regulation of the outlet water temperature at the calibration value.

It can also be used with the diverter function, so as to regulate the water flow between the heat generator and the accumulation according to the calibration temperature.

This set of valves is a fixed calibration valve, meaning that the temperature value cannot be changed.

INSTALLATION

The valve art. 4732 finds its application on the return circuit at the generator inlet (anti-condensation mixing function); installation on the supply circuit (diverter function) is also possible.

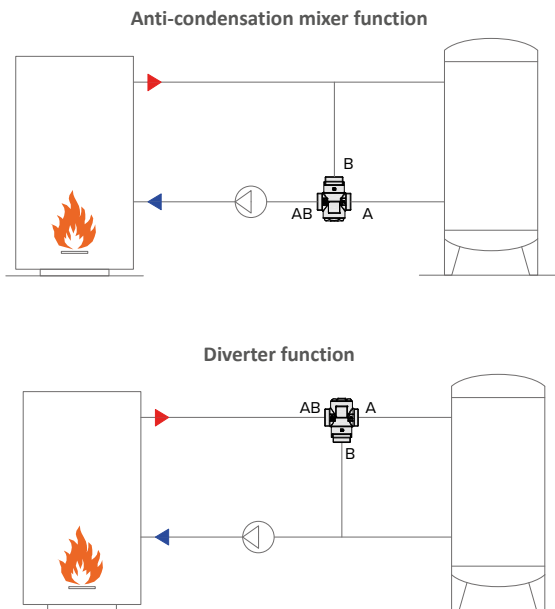

OPERATION (ANTI-CONDENSATION MIXER FUNCTION)

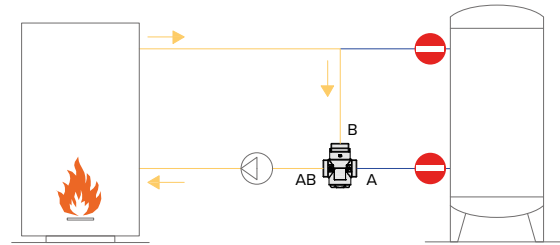

Step 1: T Generator < T Valve calibration

When the system is started, the fluid leaving the generator is cold and needs to be brought up to temperature. During this phase the by-pass (B) is fully open and the return (A) is closed. Thus, the generator is promptly heated and there is a significant reduction in the formation of condensation on the heat exchangers.

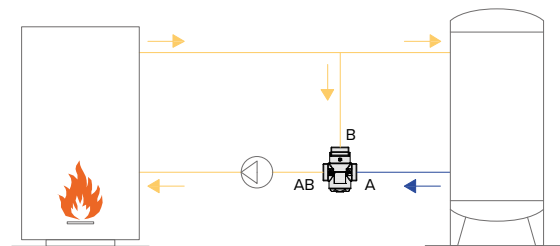

Step 2: T generator < T valve calibration

When supply temperature (B) exceeds valve setting, return (A) opens gradually, then valve starts mixing between by-pass (B) and return from accumulation (A). The temperature of the fluid entering the generator (AB) is constant and equal to the valve calibration value. This prevents the formation of condensation.

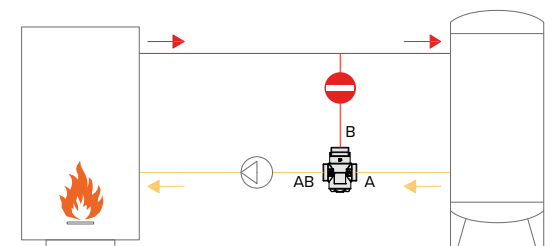

Step 3: T generator > (T valve calibration + 8°C)

As soon as the temperature on the mixed path (AB) exceeds the set value of approximately 8°C, the by-pass (B) closes while the return from the accumulation (A) is fully opened.



PRODUCT RANGE



4732

Anti-condensation valve

i Other calibrations available as an option

Code	Type	Price €	Unit/Box
324 0017	1" 60°C		1/8
324 0018	1"1/4 60°C		1/8
324 0019	1"1/2 60°C		1/8

ACCESSORIES AND SPARE PARTS



1521CPKIT

Union kit

i The kit includes: 3 tails, 3 nuts and 3 gaskets

Code	Type	Price €	Unit/Box
150 1017	1"1/4 F x 1" M		1/20
150 1013	1"1/4 F x 1" M		1/15
150 1014	1"1/2 F x 1"1/4 M		1/10

The differential by-pass valves art. 6534G are generally used in systems subject to significant flow rate variations to allow the system circulator pump to work as close as possible to its nominal pressure head value and in this way ensure correct system functioning.

Differential bypass valves are used in radiator, fan coil and radiant panel systems without differential bypass and a variable delivery pump to avoid annoying noises in the system and pump damages when several thermostatic heads, electro-thermal servo drives or zone valves are closed at the same time.

The valve is adjusted manually using the knob provided with a graduated scale where the calibration value required by the system can be easily and directly read.

OPERATION

The fluid that has to be rerouted enters in 1 where it meets the resistance of an obturator (2). The pressure acting on the fluid is adjusted by the knob (3) that compresses the spring (4). The pressure value can vary from 0 to 400 mbar (0 ÷ 4 m of WC); when the upstream pressure exceeds the set value, the obturator opens and lets the excess fluid sent by the pump return to the central system.

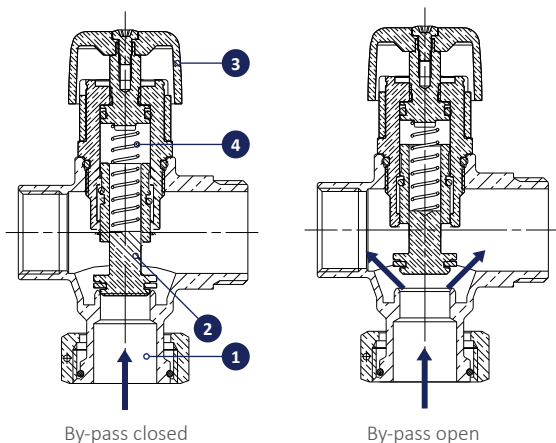

During system operation, the flow rate required for heating can vary depending on the request. This variation is due to the fact that the thermostatic valves open and close according to the heat request of each single venue. During the design phase, the required flow rate calculation is carried out with the circuit totally open and, therefore, when more valves close the excessive flow rate must be eliminated to avoid malfunctioning and noises inside the system.

In picture 1 it is possible to see the load loss of the circuit totally open; the intersection with the pump curve identifies the work point (1). The design load loss ΔP_{nom} is therefore identified.

When some valves are closed, the work point changes. In picture 2 it is possible to see how the flow rate reduction moves the work point from 1 to 2. This unnecessary flow rate (ΔQ) is therefore rerouted by the differential by-pass valve art. 6534G.

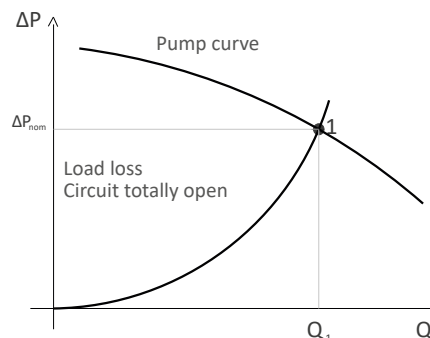

Fig. 1

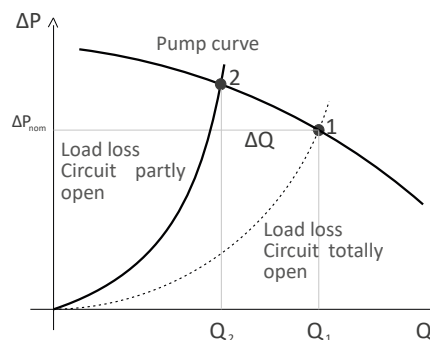
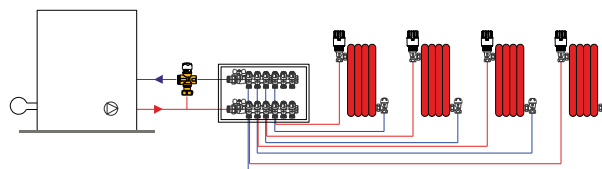

Fig. 2

INSTALLATION EXAMPLE

CIRCUIT TOTALLY OPEN



CIRCUIT PARTLY OPEN

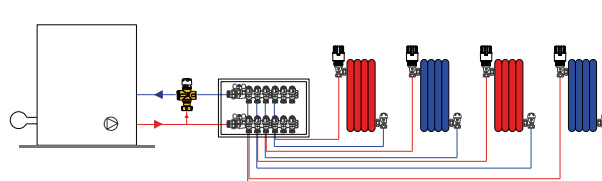

PRODUCTION RANGE



6534G
Differential by-pass valve







TECHNICAL SPECIFICATIONS

- Max. operating temperature: 100 °C
- Max. operating pressure: 10 bar
- Adjustment range: 0-400 mbar
- Material body: CW617N brass

Code	Type			Price €	Unit/Box
	1	2	3		
651 0007	1" F - 1" M - 3/4" F				2/10



05 BALANCING DEVICES



05A	System balancing - Introduction		88
05B	Static balancing valves (SBV)		90
05C	Dynamic balancing valves (PICV)		94
05D	Balancing valves with differential pressure control (DPCV)		112
05E	Balancing valves with differential pressure control (PIBCV)		117
05F	Accessories for balancing valves		119
05G	Multifunction kit for air terminal units		121

The correct operation of a thermal installation is closely linked to the balance of the distribution network. In fact, the design flow rate must be available to all delivery units, even those most at a disadvantage.



A properly balanced system ensures:





- ENERGY SAVING
- SYSTEM EFFICIENCY
- COMFORTABLE SURROUNDINGS
- LOWER SERVICING AND SUPPORT COSTS
- FEWER COMPLAINTS



In heating systems, balancing systems mainly fall into three recognized categories:

1) MANUAL STATIC FLOW RATE BALANCING		
<p>DEVICE USED: Static balancing valves. (SBV: Static Balancing Valve)</p> 	<p>OPERATION: They maintain the flow rate constant to design conditions.</p> <p>The position of the shutter is adjusted by operating the calibration knob to create a load loss and thus stabilize the flow rate of a branch of the circuit.</p>	<p>FIELD OF APPLICATION - INSTALLATION: Heating systems with constant flow rate.</p> <p>They are installed on the return circuit of the hydraulic branch to be balanced.</p>
2) AUTOMATIC DYNAMIC FLOW RATE BALANCING		
<p>DEVICE USED: Dynamic balancing valves, commonly called flow rate stabilizers. (PICV: Pressure Independent Control Valve)</p> 	<p>OPERATION: These keep the flow rate of the system constant when the differential pressure (ΔP) varies due to the intervention of the regulating elements (e.g. servomotors, thermostatic heads, etc.).</p> <p>The desired flow rate value is set by adjusting the flow rate cartridge.</p>	<p>FIELD OF APPLICATION - INSTALLATION: Heating systems with variable flow rate.</p> <p>For installation on the return circuit of the hydraulic branch to be balanced, or of each individual terminal element (e.g. fan convactor).</p>
3) DIFFERENTIAL PRESSURE REGULATION		
<p>DEVICE USED: Balancing valves with differential pressure control. (DPCV: Differential Pressure Control Valve)</p> 	<p>OPERATION: They control and maintain a constant differential pressure value (ΔP) between two specific points of the system (e.g. on risers) as the flow required by the system changes.</p> <p>Some types of differential pressure control valves intrinsically allow for adjusting the maximum flow rate (PIBCV: Pressure Independent Balancing and Control Valve).</p>	<p>FIELD OF APPLICATION - INSTALLATION: Heating systems with variable flow rate.</p> <p>In centralized systems, equipped with thermostatic valves or motorized valves, they perform the vital role of preventing noise issues from the regulating elements, which occur when the differential pressure is too high.</p> <p>The hydraulic system is regulated by the combined action of two devices connected together by means of a copper capillary tube:</p> <ul style="list-style-type: none"> • The ΔP control valve installed on the system return line. • the control/calibration device (commonly called "partner valve") installed on the supply line.



1) MANUAL STATIC FLOW RATE BALANCING		
Model	 6535G page 93	 6535DN page 93
Range	1/2" ÷ 2"	DN65 ÷ DN200
Fittings	Threaded	Flanged
Adjustment	Calibration knob with "memory stop" function. Calibration when the system is running.	Calibration knob with "memory stop" function. Calibration when the system is running.
Accessories	6535ISOL (insulation)	6535DNISOL (insulation)
Pressure plugs	Standard	Standard

2) AUTOMATIC DYNAMIC FLOW RATE BALANCING					
Model	 6541CC (TIEMME-BASIC) page 96	 6542CC (TIEMME-EASY) page 98	 6542CCS (TIEMME-AUTO) page 103	 6541DN (TIEMME-EASY HIGH FLOW RATE) page 106	 6544DN (TIEMME-AUTO HIGH FLOW RATE) page 111
Range	1/2" ÷ 1"	1/2" ÷ 2"	1/2" ÷ 2"	DN65 ÷ DN250	DN65 ÷ DN250
Fittings	Threaded	Threaded	Threaded	Flanged	Flanged
Adjustment	Internally-adjustable cartridge. Calibration during installation before filling the system.	Cartridge externally adjustable via key. Calibration when the system is running.	Cartridge externally adjustable via key. Calibration when the system is running.	Cartridge externally adjustable via key. Calibration when the system is running.	Touchscreen display. Calibration when the system is running.
Accessories	6452PP (pressure plugs)	6543CH (key)	6542SERV 6542SERV2 6542ATT (servomotor) 6543CH (key) 6545CH (key)	6543CH (key)	-
Pressure plugs	Accessory	Standard	Standard	Standard	Standard

3) DIFFERENTIAL PRESSURE REGULATION			
Model	 6538 page 113	 6539 - ("PARTNER VALVE") page 113	 6540 page 118
Range	1/2" ÷ 2"	1/2" ÷ 2"	1/2" ÷ 1"
Fittings	Threaded	Threaded	Threaded
Adjustment	Cartridge externally adjustable via key. Calibration when the system is running.	Calibration knob with "memory stop" function. Calibration when the system is running.	Cartridge externally adjustable via key. Calibration when the system is running.
Accessories	6539 ("partner valve") 6543CH (key)	-	6542ATT (servomotor) 6543CH (key) 1570 + 1581 (fitting)
Pressure plugs	Standard	Standard	Standard

WHAT ARE STATIC BALANCING VALVES FOR?

Static balancing valves are valves in which the valve stem position can be adjusted to create a load loss in the system and stabilize the flow rate occurring on a given branch. They are therefore comparable to lockshield valves. The flow rate is set during installation via the calibration knob and accordingly on the maximum design flow rate.

Static balancing valves are recommended in applications with constant flow rates.

HOW DO I SIZE A STATIC BALANCING VALVE?

Sizing a static balancing valve presupposes the exact calculation of the flow rate necessary for the system. This itself is calculated based on the power of the heat exchange units to be installed (radiators, radiant system, fan convectors etc) and of the thermal gradient to be obtained, according to the following formula:

$$Q = P \cdot 0.86 / \Delta t \text{ then } P = (Q \cdot \Delta t) / 0.86$$

where:

Q = circulating water flow rate (l/h);

P = system thermal power (W);

ΔT = water temperature difference between generator supply and return.

It is then necessary to take into account the static balancing valve load loss generated on the branch where it is to be installed in order to understand the valve's degree of authority.

WHAT IS THE AUTHORITY OF A VALVE?

The authority of a regulating valve is expressed by the ratio between the load loss the valve causes when it is fully open and crossed by the design flow rate and the total load loss on the branch it is inserted on, including the regulating valve. A regulating valve is said to have minimal authority when its load loss is very small compared to that of the circuit as a whole. On the contrary, the higher the load loss produced by the valve than the overall loss in the branch, the greater its authority.

If a static balancing valve has minimal authority, then to produce a regulating effect it is necessary to close it almost completely. However, this can create difficulties in stabilizing the flow rate according to the desired value. When the valve has high authority, it is the latter that controls the regulation because the circuit load loss has limited influence since it is a largely insignificant value with respect to the valve load loss. The optimum balance is achieved when the load loss on the fully open regulating valve is approximately the same as the load loss on the rest of the system: Valve authority of approximately 50%.

It bears highlighting that in a system with balancing organs, the choice of circulating pump must also take into account valve load loss in order to be correctly sized and have the right prevalence.



FLOW RATE CALCULATION

To calculate the flow rate, balancing valves use the Venturi principle.

This principle demonstrates how the pressure of a fluid stream increases as the speed decreases. Therefore, if there is a section decrease (as shown in the figure), there will be a certain speed and a certain pressure in the larger section, whereas in the smaller section there is a higher speed and, following the Venturi principle, a lower pressure than that of the inlet. This pressure difference ΔP created between inlet and outlet can be converted, via the Bernoulli equation, into a flow rate Q .

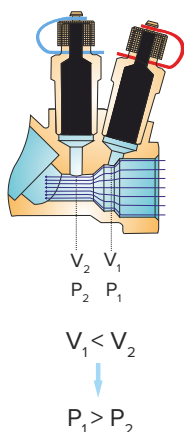

The flow rate through the valve can be viewed via special electronic instrument art. 6536 or via any differential pressure manometer.



Reading takes place by inserting two probes into the pressure plugs. These plugs are quick-coupling and measure quickly and accurately. When the measuring probes are removed, the plugs automatically close and prevent water from escaping.

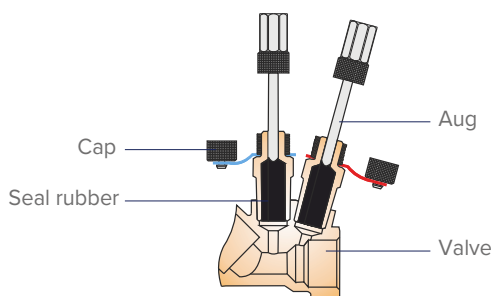

Insertion / extraction of pressure test points

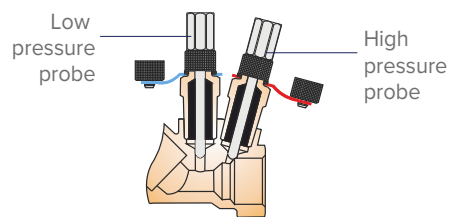

Pressure measurement

IN-TRANSIT FLOW RATE CALCULATION

$$Q = Kv\sqrt{\Delta P}$$

Flow rate correction Q' for liquids with ρ other than 1kg/dm^3 :

$$Q' = \frac{Q}{\sqrt{\rho'}}$$

where:

- ΔP = differential pressure measured in bar
- Q = flow rate in m^3/h (valid for water with a temperature of 0 to 30 °C and $\rho \approx 1\text{ kg/dm}^3$);
- Q' = correct flow rate in m^3/h ;
- KV = valve hydraulic characteristic in m^3/h ;
- ρ' = liquid density in kg/dm^3 .

INSTALLATION RECOMMENDATIONS

- Install valve after carefully flushing the system.
- Maintain free access to the valve and calibration handwheel;
- Follow the direction of flow indicated on the valve body;
- Valve can be installed both vertically and horizontally;
- In the horizontal sections, keep the pressure plugs facing upwards to prevent dirt and sludge settlement;
- Avoid installation close to circulation pumps, sudden widening or narrowing of the network and bends so as not to compromise the correct reading of the differential pressure;
- The valve and the pipe on which it is fitted must have the same nominal diameter.
- Select the balancing valve so that the degree of design flow rate adjustment corresponds approximately to a half-turn on the shutter so that a certain flexibility of the calibration is ensured, even after possible changes to the system while in operation.

INSTALLATION EXAMPLES

Diagram 1: Balancing individual autonomous zones and risers

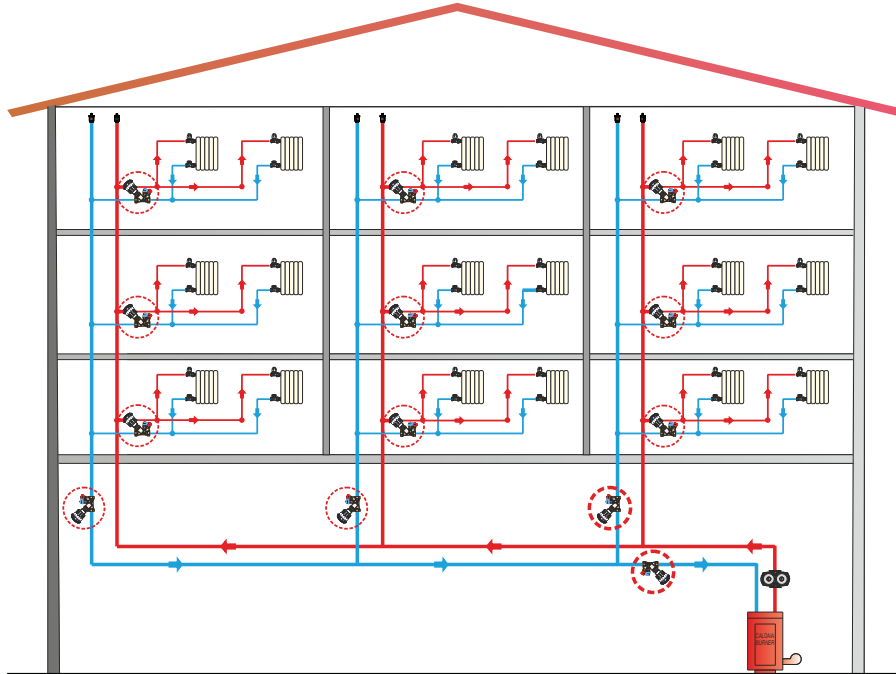
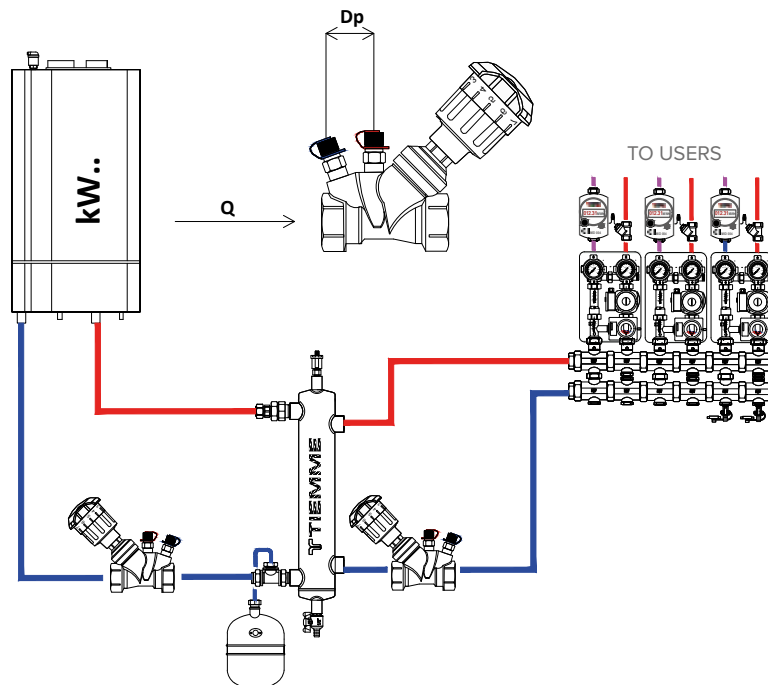

Diagram 2: Primary and secondary side system balancing



ADVANTAGES / STRENGTHS

- Calibrated orifice;
- Easy adjustment thanks to the calibration knob;
- Double pressure plugs;
- “Memory stop” function: allows the calibration position to be set easily and safely.

PRODUCT RANGE



6535G

Brass balancing valve with quick-coupling pressure plugs

i Accessories: 6535ISOL - 6535ET - 6536
Spare parts: 6535PP
For codes see page 119

Code	Type	Price €	Unit/Box
651 0008	1/2"		1/5
651 0009	3/4"		1/5
651 0010	1"		1/5
651 0011	1"1/4		1/5
651 0012	1"1/2		1/4
651 0013	2"		1/4



6535DN

Cast iron balancing valve with quick-coupling pressure plugs

i Accessories: 6535DNISOL - 6535ET - 6536
Spare parts: 6535PP - 6535DNMANOP
For codes see page 119

Code	Type	Price €	Unit/Box
651 0269	DN65		1/1
651 0270	DN80		1/1
651 0271	DN100		1/1
651 0272	DN125		1/1
651 0273	DN150		1/1
651 0274	DN200		1/1

CALIBRATION

The balancing valve can be adjusted from 0.0 (valve fully closed) to a value that varies according to valve diameter.

The number before the decimal point represents the number of full revolutions that the knob performs, the number after the decimal point is a micrometric value that divides the revolution into 10 parts.

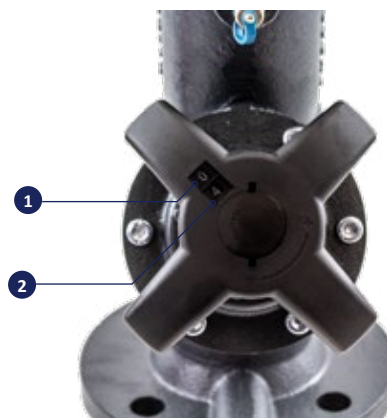
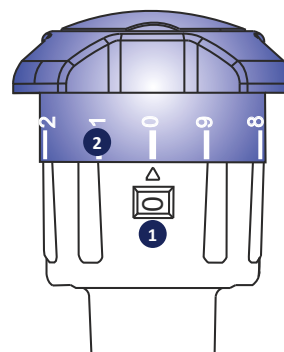

1. No. of revolutions
2. Micrometric value

The Tiemme PICV (Pressure Independent Control Valves) dynamic balancing valves keep the design flow rate constant as the operating conditions of the hydraulic circuit vary. The desired flow rate value is set by means of an adjustable flow cartridge. Designed to ensure the flow rate to individual utilities and on risers, Tiemme dynamic balancing valves are easily calibrated. Tiemme devices are low noise and calibration accuracy. Tiemme dynamic balancing valves with brass body are pre-configured for the insertion of pressure plugs in the TIEMME-BASIC versions, for the reading of the differential pressure and the indirect calculation of the flow rate by means of a differential pressure manometer. The TIEMME-EASY and TIEMME-AUTO versions come complete with pressure plugs.

ADVANTAGES / STRENGTHS

- Keep the flow rate constant as the operating conditions of the system vary;
- Applicable to individual utility inlets or on risers;
- Simple calibration;
- Perfect solution for variable flow systems;
- Wide range of flow rates can be set thanks to the cartridges available for each valve body.

PRINCIPLE OF OPERATION

The pressure **P2** is set by the diaphragm in reaction to the pressure **P1** acting on the diaphragm's upper chamber. Interacting with the spring, the difference (**P1-P2**) remains constant, maintaining a constant ΔP through the bore orifice. **As a result, a constant flow rate through the valve is obtained regardless of variations in the pressure difference between upstream and downstream.**

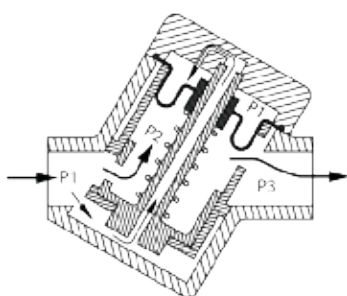

Insert with spring/diaphragm action

where:

- **P1 and P3:** Pressures in the circuits
- **P2:** Pressure set by the diaphragm
- $\Delta P = (P1 - P3)$ = total pressure difference between upstream and downstream

AVAILABLE VERSIONS

TIEMME-BASIC

With internally-adjustable cartridge and pressure plug fittings (optional). Stabilizes the flow rate at the desired value. Adjustment to be made before installation.



- Internal adjustment;
- DN15 ÷ DN25 small;
- 10 cartridges depending on pressure loss (ΔP) and flow rate;
- Up to 8 flow rate values per cartridge.

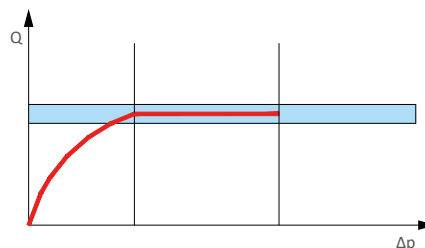

TIEMME-EASY

With externally-adjustable cartridge and pressure plugs. Stabilizes the flow rate to the desired value and can be recalibrated even when the system running.



- External adjustment;
- DN15 ÷ DN50;
- 6 cartridges depending on pressure loss (ΔP) and flow rate;
- 40 flow rate values for each cartridge.

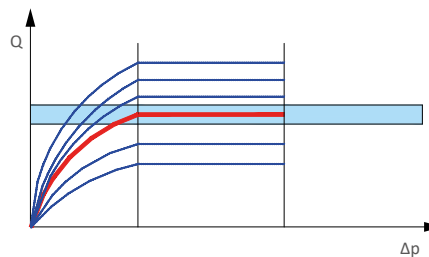

TIEMME-AUTO

With servomotor and pressure plugs. Stabilizes the flow rate at a value set by an external control (including modulating).



- DN15 ÷ DN50;
- 3 cartridges depending on pressure loss (ΔP) and flow rate;
- 40 flow rate values for each cartridge.

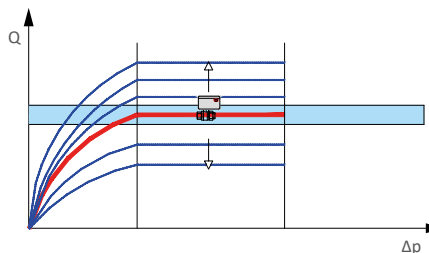

INSTALLATION

Tiemme dynamic balancing valves are typically installed on the return branch of the hydraulic circuit. Placing a suitable filter before the valve is recommended to protect the balancing device from any dirt that may impair its proper operation. Tiemme dynamic balancing valves can be installed on both horizontal and vertical branches, always following the direction of the heat transfer fluid as indicated on the valve body.

Diagram 1: Riser balancing function

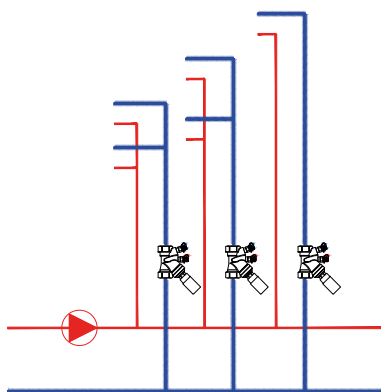
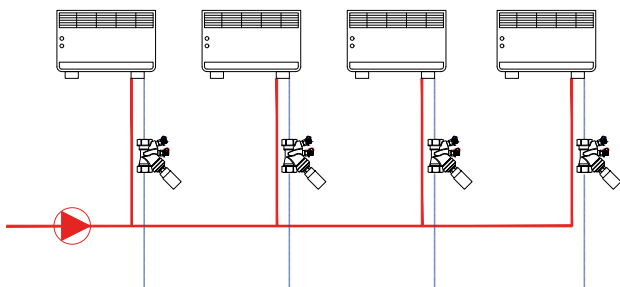

Diagram 2: Balancing function of individual terminal elements



SELECTION GUIDE

To easily find the right valve for the projected application, we recommend following the steps below:

- Choose the valve type according to own technical/budget requirements: pay attention to the technical features of the adjustment valves. For example, the TIEMME-basic valves only allow adjustment during pre-installation. Therefore intercepting them in order to carry out a recalibration in subsequent steps is advisable. The TIEMME-EASY and TIEMME-AUTO valves allow adjustment in retrospect even when the system is s.
- Choose the diameter of the valve body equal to the diameter of the pipe on which it will be installed;
- On the "Range ΔP " riser, choose the valve's required ΔP , i.e. the value of the differential pressure range at which the valve will work;
- To select cartridge, turn to the relevant tables listing the individual calibrations. As far as possible, the cartridge should be chosen with a central calibration flow rate value relative to the possibility of its being set to deal with any disparities, should they arise, between the design and the system when in operation.

Example

A constant flow rate of 360 l/h to a fan coil supplied by a DN20 pipe must be ensured.

- Make valve choice according to own technical/budget requirements (for example TIEMME-BASIC);
- Choose a valve with a DN20 body equal to the pipe on which it will be installed;
- Check the ΔP field of the system (example ΔP 20-130 kPa).
- Turn to the selection table for the DN20 cartridge with ΔP 20-130 kPa.
- The RED is the correct cartridge, since it allows calibration at a flow rate slightly higher than that required by the fan coil (378 l/h) at a calibration value of 6, which is right at the central point of the setting field, allowing possible corrections in the operating phase.

l/sec	l/h	Cartridge colour ■ RED
0.0383	138	
0.0431	155	
0.0450	162	
0.0575	207	4
0.0619	223	
0.0669	241	
0.0922	332	5
0.0978	352	
0.105	378	6
0.114	409	7
0.115	415	
0.118	426	
0.119	430	8
0.136	489	
0.137	492	

Central point to the setting field

05_C DYNAMIC BALANCING VALVES (PICV)

TIEMME-BASIC



6541CC

TIEMME-BASIC flow rate stabilizers with internally-adjustable cartridge and fittings for pressure plugs (optional)

i Accessories: 6542PP - 6535ET
For codes see page 119

Code	Valve body	Cartridge size	Range ΔP	Cartridge colour	Flow rate l/h	Price €	Unit/Box
651 0753	1/2" (DN15)	DN20	20 - 130 kPa	Grey	29 - 155		1/10
651 0754			20 - 130 kPa	Red	207 - 430		1/10
651 0755			20 - 130 kPa	Blue	223 - 526		1/10
651 0756			20 - 130 kPa	Black	162 - 695		1/10
651 0757			20 - 130 kPa	Green	112 - 984		1/10
651 0758			40 - 400 kPa	Grey	42 - 250		1/10
651 0760			40 - 400 kPa	Red	281 - 653		1/10
651 0762			40 - 400 kPa	Blue	203 - 792		1/10
651 0764			40 - 400 kPa	Black	215 - 998		1/10
651 0765			40 - 400 kPa	Green	529 - 1470		1/10
651 0766	3/4" (DN20)	DN20	20 - 130 kPa	Grey	29 - 155		1/10
651 0767			20 - 130 kPa	Red	207 - 430		1/10
651 0768			20 - 130 kPa	Blue	223 - 526		1/10
651 0769			20 - 130 kPa	Black	162 - 695		1/10
651 0770			20 - 130 kPa	Green	112 - 984		1/10
651 0771			40 - 400 kPa	Grey	42 - 250		1/10
651 0772			40 - 400 kPa	Red	281 - 653		1/10
651 0773			40 - 400 kPa	Blue	203 - 792		1/10
651 0774			40 - 400 kPa	Black	215 - 998		1/10
651 0775			40 - 400 kPa	Green	529 - 1470		1/10
651 0776	1" (DN25 small)	DN20	20 - 130 kPa	Grey	29 - 155		1/10
651 0777			20 - 130 kPa	Red	207 - 430		1/10
651 0778			20 - 130 kPa	Blue	223 - 526		1/10
651 0779			20 - 130 kPa	Black	162 - 695		1/10
651 0780			20 - 130 kPa	Green	112 - 984		1/10
651 0781			40 - 400 kPa	Grey	42 - 250		1/10
651 0782			40 - 400 kPa	Red	281 - 653		1/10
651 0783			40 - 400 kPa	Blue	203 - 792		1/10
651 0784			40 - 400 kPa	Black	215 - 998		1/10
651 0785			40 - 400 kPa	Green	529 - 1470		1/10



05_c DYNAMIC BALANCING VALVES (PICV)

TIEMME-BASIC

GUIDE TO CHOOSING CARTRIDGE WITH INTERNAL ADJUSTMENT

FLOW RATE ADJUSTMENT

Cartridge adjustment using 6 mm Allen key.

The calibration operations must be carried out at installation before filling the system

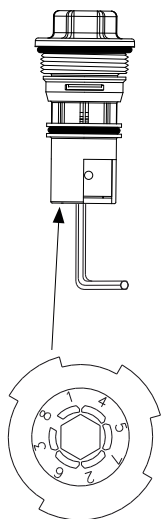

DN20 cartridges for Tiemme-Basic valves
DN15-DN20-DN25 SMALL
Pressure range ΔP: 20-130 kPa

Nominal flow rate	l/sec	l/h	Setting					
			1	2	3	4	5	
0.0081	29.2	29.2	1					
0.0133	47.9	47.9	2					
0.0175	63.0	63.0	3					
0.0222	79.9	79.9	4					
0.0311	112	112	5					1
0.0353	127	127	6					
0.0383	138	138	7					
0.0431	155	155	8					
0.0450	162	162					3	
0.0575	207	207	4					
0.0619	223	223			4			
0.0669	241	241				4		
0.0922	332	332	5					
0.0978	352	352						
0.105	378	378	6					
0.114	409	409	7					
0.115	415	415			5			
0.118	426	426						2
0.119	430	430	8					
0.136	489	489						3
0.137	492	492			6			
0.138	498	498						4
0.146	524	524			7			
0.146	526	526			8			
0.155	557	557					5	
0.176	635	635					6	
0.180	647	647					7	
0.193	695	695					8	
0.231	830	830						5
0.237	854	854						6
0.253	909	909						7
0.273	984	984						8

DN20 cartridges for Tiemme-Basic valves
DN15-DN20-DN25 SMALL
Pressure range ΔP: 40-400 kPa

Nominal flow rate	l/sec	l/h	Setting					
			1	2	3	4	5	
0.0117	42.1	42.1	1					
0.0189	68.0	68.0	2					
0.0247	88.9	88.9	3					
0.0325	117	117	4					
0.0472	170	170	5					
0.0528	190	190	6					
0.0564	203	203			3			
0.0597	215	215				3		
0.0639	230	230	7					
0.0694	250	250	8					
0.0781	281	281		4				
0.0908	327	327			4			
0.0958	345	345				4		
0.137	493	493		5				
0.147	529	529						1
0.161	581	581			6			
0.173	624	624			7			
0.181	652	652				5		
0.181	653	653			8			
0.186	670	670						2
0.210	755	755						3
0.216	779	779			6			
0.218	785	785			7			
0.220	792	792			8			
0.237	853	853					5	
0.241	869	869						4
0.266	957	957					6	
0.269	968	968					7	
0.277	998	998					8	
0.365	1320	1320						5
0.369	1330	1330						6
0.392	1410	1410						7
0.408	1470	1470						8

05_C DYNAMIC BALANCING VALVES (PICV)

TIEMME-EASY



6542CC

TIEMME-EASY flow rate stabilizers with externally-adjustable cartridge, with pressure plugs

i Accessories: 6543CH - 6535ET
Spare parts: 6542PP
For codes see page 119

Code	Valve body	Cartridge size	Range ΔP	Cartridge colour	Flow rate l/h	Price €	Unit/Box
651 0786	1/2" (DN15)	DN20	17 - 210 kPa	■ Black	100 - 412		1/10
651 0787			17 - 210 kPa	■ Green	157 - 609		1/10
651 0788			35 - 400 kPa	■ Black	138 - 615		1/10
651 0789			35 - 400 kPa	■ Green	238 - 896		1/10
651 0790			17 - 200 kPa	■ Red - □ White	276 - 825		1/10
651 0791	3/4" (DN20)	DN20	30 - 400 kPa	■ Red ■ - Grey	406 - 1270		1/10
651 0792			17 - 210 kPa	■ Black	100 - 412		1/10
651 0793			17 - 210 kPa	■ Green	157 - 609		1/10
651 0794			35 - 400 kPa	■ Black	138 - 615		1/10
651 0795			35 - 400 kPa	■ Green	238 - 896		1/10
651 0796			17 - 200 kPa	■ Red - □ White	276 - 825		1/10
651 0797			30 - 400 kPa	■ Red ■ - Grey	406 - 1270		1/10
651 0798			17 - 210 kPa	■ Black	100 - 412		1/10
651 0799			17 - 210 kPa	■ Green	157 - 609		1/10
651 0800			1" (DN25 small)	DN20	35 - 400 kPa	■ Black	138 - 615
651 0801	35 - 400 kPa	■ Green			238 - 896		1/10
651 0802	17 - 200 kPa	■ Red - □ White			276 - 825		1/10
651 0803	1" (DN25 large)	DN40	30 - 400 kPa	■ Red ■ - Grey	406 - 1270		1/10
651 0804			17 - 400 kPa	■ Black	535 - 5830		1/4
651 0805			17 - 400 kPa	■ Black	535 - 5830		1/4
651 0806			1"1/2 (DN40)	DN50	20 - 400 kPa	□ White	3180 - 16100
651 0807	2" (DN50)	DN50	20 - 400 kPa	□ White	3180 - 16100		1/10



05_c DYNAMIC BALANCING VALVES (PICV)

TIEMME-EASY (DN15-DN20-DN25 SMALL)

GUIDE TO SELECTING EXTERNALLY-ADJUSTABLE CARTRIDGES

FLOW RATE ADJUSTMENT

Cartridge adjustment using
Tiemme key art. 6543CH.

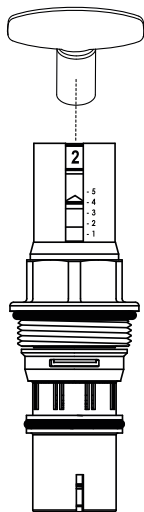

DN20 cartridges - for Tiemme-Easy valve DN15-DN20-DN25 small Pressure range ΔP: 17-210 kPa

I/sec	I/h	Setting	
		■	■
0.0278	100	1.0	
0.0299	108	1.1	
0.0321	116	1.2	
0.0343	123	1.3	
0.0364	131	1.4	
0.0386	139	1.5	
0.0408	147	1.6	
0.0429	155	1.7	
0.0436	157		1.0
0.0451	162	1.8	
0.0468	168		1.1
0.0473	170	1.9	
0.0494	178	2.0	
0.0499	180		1.2
0.0516	186	2.1	
0.0530	191		1.3
0.0538	194	2.2	
0.0559	201	2.3	
0.0562	202		1.4
0.0581	209	2.4	
0.0593	214		1.5
0.0603	217	2.5	
0.0624	225	2.6	1.6
0.0646	233	2.7	
0.0656	236		1.7
0.0668	240	2.8	
0.0687	247		1.8
0.0689	248	2.9	
0.0711	256	3.0	
0.0719	259		1.9
0.0733	264	3.1	
0.0750	270		2.0
0.0754	272	3.2	
0.0776	279	3.3	
0.0781	281		2.1
0.0798	287	3.4	
0.0813	293		2.2
0.0819	295	3.5	
0.0841	303	3.6	
0.0844	304		2.3
0.0863	311	3.7	

I/sec	I/h	Setting	
		■	■
0.0876	315		2.4
0.0884	318	3.8	
0.0906	326	3.9	
0.0907	327		2.5
0.0928	334	4.0	
0.0938	338		2.6
0.0949	342	4.1	
0.0970	349		2.7
0.0971	350	4.2	
0.0993	357	4.3	
0.100	360		2.8
0.101	365	4.4	
0.103	372		2.9
0.104	373	4.5	
0.106	381	4.6	
0.106	383		3.0
0.108	389	4.7	
0.110	394		3.1
0.110	396	4.8	
0.112	404	4.9	
0.113	406		3.2
0.114	412	5.0	
0.116	417		3.3
0.119	428		3.4
0.122	440		3.5
0.125	451		3.6
0.128	462		3.7
0.132	473		3.8
0.135	485		3.9
0.138	496		4.0
0.141	507		4.1
0.144	519		4.2
0.147	530		4.3
0.150	541		4.4
0.153	553		4.5
0.157	564		4.6
0.160	575		4.7
0.163	586		4.8
0.166	598		4.9
0.169	609		5.0

05_c DYNAMIC BALANCING VALVES (PICV)

TIEMME-EASY (DN15-DN20-DN25 SMALL)

GUIDE TO SELECTING EXTERNALLY-ADJUSTABLE CARTRIDGES

FLOW RATE ADJUSTMENT

Cartridge adjustment using Tiemme key art. 6543CH.

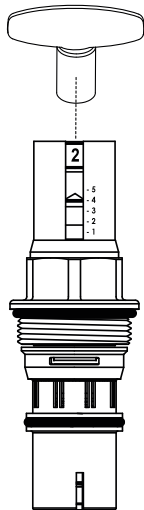

DN20 cartridge - for Tiemme-Easy valve DN15-DN20-DN25 Small
Pressure range ΔP : 35-400 kPa

Nominal flow rate	l/sec	l/h	Setting	
			■	■
	0.0383	138	1.0	
	0.0416	150	1.1	
	0.0449	162	1.2	
	0.0483	174	1.3	
	0.0516	186	1.4	
	0.0549	198	1.5	
	0.0582	210	1.6	
	0.0615	221	1.7	
	0.0648	233	1.8	
	0.0660	238		1.0
	0.0681	245	1.9	
	0.0706	254		1.1
	0.0714	257	2.0	
	0.0748	269	2.1	
	0.0751	271		1.2
	0.0781	281	2.2	
	0.0797	287		1.3
	0.0814	293	2.3	
	0.0843	304		1.4
	0.0847	305	2.4	
	0.0880	317	2.5	
	0.0889	320		1.5
	0.0913	329	2.6	
	0.0934	336		1.6
	0.0946	341	2.7	
	0.0979	353	2.8	
	0.0980	353		1.7
	0.101	365	2.9	
	0.103	369		1.8
	0.105	377	3.0	
	0.107	386		1.9
	0.108	388	3.1	
	0.111	400	3.2	
	0.112	402		2.0
	0.115	412	3.3	
	0.116	419		2.1
	0.118	424	3.4	
	0.121	435		2.2
	0.121	436	3.5	
	0.124	448	3.6	
	0.125	452		2.3

Nominal flow rate	l/sec	l/h	Setting	
			■	■
	0.128	460	3.7	
	0.130	468		2.4
	0.131	472	3.8	
	0.134	484	3.9	
	0.135	485		2.5
	0.138	496	4.0	
	0.139	501		2.6
	0.141	508	4.1	
	0.144	517		2.7
	0.144	520	4.2	
	0.148	532	4.3	
	0.148	534		2.8
	0.151	544	4.4	
	0.153	550		2.9
	0.154	556	4.5	
	0.157	567		3.0
	0.158	567	4.6	
	0.161	579	4.7	
	0.162	583		3.1
	0.164	591	4.8	
	0.167	600		3.2
	0.168	603	4.9	
	0.171	615	5.0	
	0.171	616		3.3
	0.176	633		3.4
	0.180	649		3.5
	0.185	666		3.6
	0.189	682		3.7
	0.194	699		3.8
	0.199	715		3.9
	0.203	731		4.0
	0.208	748		4.1
	0.212	764		4.2
	0.217	781		4.3
	0.221	797		4.4
	0.226	814		4.5
	0.231	830		4.6
	0.235	847		4.7
	0.240	863		4.8
	0.244	880		4.9
	0.249	896		5.0



05_c DYNAMIC BALANCING VALVES (PICV)

TIEMME-EASY (DN15-DN20-DN25 SMALL)

GUIDE TO SELECTING EXTERNALLY-ADJUSTABLE CARTRIDGES

FLOW RATE ADJUSTMENT
Cartridge adjustment using
Tiemme key art. 6543CH.

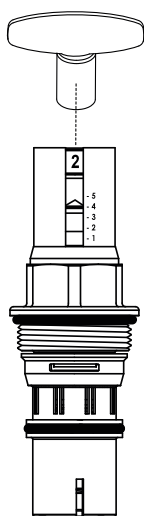

**DN20 cartridge for Tiemme-Easy valves
DN15-DN20-DN25 Small
Pressure range ΔP: 17-200 kPa**

	l/sec	l/h	Setting	
			■	□
Nominal flow rate	0.0767	276	1.0	
	0.0813	293	1.1	
	0.0860	310	1.2	
	0.0907	326	1.3	
	0.0953	343	1.4	
	0,100	360	1.5	
	0.105	377	1.6	
	0.109	393	1.7	
	0.114	410	1.8	
	0.118	426	1.9	
	0.123	443	2.0	
	0.128	459	2.1	
	0.132	475	2.2	
	0.136	491	2.3	
	0.141	507	2.4	
	0.145	523	2.5	
	0.150	539	2.6	
	0.154	554	2.7	
	0.158	569	2.8	
	0.162	584	2.9	
	0.166	599	3.0	
	0.170	614	3.1	
	0.174	628	3.2	
	0.178	642	3.3	
	0.182	655	3.4	
	0.186	669	3.5	
	0.189	682	3.6	
	0.193	695	3.7	
	0.196	707	3.8	
	0.200	719	3.9	
0.203	731	4.0		
0.206	742	4.1		
0,209	753	4.2		
0.212	764	4.3		
0.215	774	4.4		
0.218	784	4.5		
0.220	793	4.6		
0.223	802	4.7		
0.225	810	4.8		
0.227	818	4.9		
0.229	825	5.0		

**DN20 cartridge for Tiemme-Easy valves
DN15-DN20-DN25 Small
Pressure range ΔP: 30-400 kPa**

	l/sec	l/h	Setting	
			■	■
Nominal flow rate	0.113	406	1.0	
	0.119	427	1.1	
	0.125	449	1.2	
	0.131	470	1.3	
	0.137	492	1.4	
	0.143	513	1.5	
	0.149	535	1.6	
	0.155	556	1.7	
	0.161	578	1.8	
	0.167	599	1.9	
	0.172	621	2.0	
	0.178	642	2.1	
	0.184	664	2.2	
	0.190	685	2.3	
	0.196	707	2.4	
	0.202	728	2.5	
	0.208	750	2.6	
	0.214	771	2.7	
	0.220	793	2.8	
	0.226	814	2.9	
	0.232	836	3.0	
	0.238	857	3.1	
	0.244	879	3.2	
	0.250	900	3.3	
	0.256	922	3.4	
	0.262	943	3.5	
	0.268	965	3.6	
	0.274	987	3.7	
	0.280	1010	3.8	
	0.286	1030	3.9	
0.292	1050	4.0		
0.298	1070	4.1		
0,304	1090	4.2		
0,310	1120	4.3		
0.316	1140	4.4		
0.322	1160	4.5		
0.328	1180	4.6		
0.334	1200	4.7		
0.340	1220	4.8		
0.346	1240	4.9		
0.352	1270	5.0		

05_c DYNAMIC BALANCING VALVES (PICV)

TIEMME-EASY (DN25 LARGE-DN32-DN40-DN50)

GUIDE TO SELECTING EXTERNALLY-ADJUSTABLE CARTRIDGES

FLOW RATE ADJUSTMENT
Cartridge adjustment using
Tiemme key art. 6543CH.



**DN40 cartridge for Tiemme-Easy valves
DN25 Large-DN32
Pressure range ΔP : 17-400 kPa**

	l/sec	l/h	Setting
			■
Nominal flow rate	0,149	535	1.0
	0.220	793	1.1
	0.289	1040	1.2
	0.355	1280	1.3
	0.418	1510	1.4
	0.479	1730	1.5
	0.538	1940	1.6
	0.594	2140	1.7
	0.647	2330	1.8
	0.699	2520	1.9
	0.748	2690	2.0
	0.795	2860	2.1
	0.841	3030	2.2
	0.884	3180	2.3
	0.925	3330	2.4
	0.965	3470	2.5
	1.00	3610	2.6
	1.04	3740	2.7
	1.07	3870	2.8
	1.11	3990	2.9
	1.14	4100	3.0
	1.17	4220	3.1
	1.20	4320	3.2
	1.23	4420	3.3
	1.26	4520	3.4
	1.28	4620	3.5
	1.31	4710	3.6
	1.33	4800	3.7
	1.36	4890	3.8
	1.38	4970	3.9
1.40	5050	4.0	
1.43	5130	4.1	
1.45	5210	4.2	
1.47	5290	4.3	
1.49	5370	4.4	
1.51	5440	4.5	
1.53	5520	4.6	
1.55	5600	4.7	
1.58	5670	4.8	
1.60	5750	4.9	
1.62	5830	5.0	

**DN50 cartridge for Tiemme-Easy valves
DN40-DN50
Pressure range ΔP : 20-400 kPa**

	l/sec	l/h	Setting
			□
Nominal flow rate	0.883	3180	1.0
	1.14	4100	1.1
	1.37	4940	1.2
	1.59	5710	1.3
	1.78	6420	1.4
	1.96	7070	1.5
	2.13	7660	1.6
	2.28	8200	1.7
	2.42	8700	1.8
	2.54	9150	1.9
	2.66	9570	2.0
	2.77	9960	2.1
	2.86	10300	2.2
	2.95	10600	2.3
	3.04	10900	2.4
	3.12	11200	2.5
	3.19	11500	2.6
	3.26	11700	2.7
	3.32	12000	2.8
	3.39	12200	2.9
	3.45	12400	3.0
	3.51	12600	3.1
	3.56	12800	3.2
	3.62	13000	3.3
	3.67	13200	3.4
	3.73	13400	3.5
	3.78	13600	3.6
	3.83	13800	3.7
	3.89	14000	3.8
	3.94	14200	3.9
3.99	14400	4.0	
4.05	14600	4.1	
4.10	14800	4.2	
4.15	14900	4.3	
4.20	15100	4.4	
4.25	15300	4.5	
4.30	15500	4.6	
4.35	15700	4.7	
4.39	15800	4.8	
4.44	16000	4.9	
4.48	16100	5.0	





6542CCS

TIMME-AUTO flow rate stabilizer configured for servomotor or actuator connection, with pressure plugs

i Accessories: 6543CH (For Green 0, Green 1, Green 2) - 6545CH (For Green 3) - 6542SERV (For Green 0, Green 1)- 6542SERV2 (Green 3)- 6542ATT (For Green 0, Green 1, Green 2) - 6535ET
Spare parts: 6542PP
For codes see page 119

Code	Valve body	Cartridge size	Range ΔP	Cartridge colour	Flow rate l/h	Price €	Unit/Box
651 0808	1/2" (DN15)	DN20	16 - 200 kPa	Green 0	37 - 575		1/10
651 0809		DN20	30 - 800 kPa	Green 1	64 - 1110		1/10
651 0810	3/4" (DN20)	DN20	16 - 200 kPa	Green 0	37 - 575		1/10
651 0811		DN20	30 - 800 kPa	Green 1	64 - 1110		1/10
651 0812	1" (DN25 small)	DN20	16 - 200 kPa	Green 0	37 - 575		1/10
651 0813		DN20	30 - 800 kPa	Green 1	64 - 1110		1/10
651 0820	1" (DN25 large)	DN40	16 - 800 kPa	Green 2	865 - 4630		1/8
651 0821	1"1/4 (DN32)	DN40	16 - 800 kPa	Green 2	865 - 4630		1/10
651 0822	1"1/2 (DN40)	DN40	16 - 400 kPa	Green 3	1900 - 13647		1/10
651 0823	2" (DN50)	DN50	16 - 400 kPa	Green 3	1900 - 13647		1/10

05_c DYNAMIC BALANCING VALVES (PICV)

TIEMME-AUTO (DN15-DN20-DN25 SMALL)

GUIDE TO SELECTING EXTERNALLY-ADJUSTABLE CARTRIDGES

FLOW RATE ADJUSTMENT
Cartridge adjustment using
Tiemme key art. 6543CH.

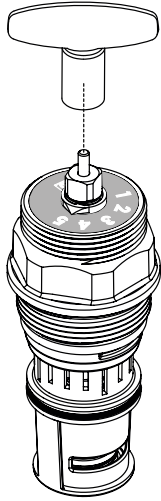

**DN20 cartridge for Tiemme-Auto valves
DN15-DN20-DN25 Small
Pressure Range ΔP : 16-200 kPa**

Nominal flow rate	l/sec	l/h	Setting
			Green 0
	-	-	1.0
	0.0103	37	1.1
	0.0233	84	1.2
	0.0322	116	1.3
	0.0419	151	1.4
	0.0500	180	1.5
	0.0569	205	1.6
	0.0650	234	1.7
	0.0719	259	1.8
	0.0781	281	1.9
	0.0839	302	2.0
	0.0889	320	2.1
	0.0942	339	2.2
	0.0981	353	2.3
	0.103	371	2.4
	0.106	381	2.5
	0.109	394	2.6
	0.113	406	2.7
	0.115	414	2.8
	0.119	428	2.9
	0.122	439	3.0
	0.125	449	3.1
	0.127	458	3.2
	0.130	468	3.3
	0.133	477	3.4
	0.135	486	3.5
	0.137	494	3.6
	0.140	503	3.7
	0.142	511	3.8
	0.144	518	3.9
	0.146	526	4.0
	0.148	532	4.1
	0.149	538	4.2
	0.151	544	4.3
	0.153	549	4.4
	0.154	553	4.5
	0.155	559	4.6
	0.156	563	4.7
	0.158	567	4.8
	0.159	571	4.9
	0.160	575	5.0

**DN20 Cartridge for Tiemme-Auto valves
DN15-DN20-DN25 Small
Pressure Range ΔP : 30-800 kPa**

Nominal flow rate	l/sec	l/h	Setting
			Green 1
	0.0178	64	1.0
	0.0393	142	1.1
	0.0580	209	1.2
	0.0743	268	1.3
	0.0887	319	1.4
	0.102	366	1.5
	0.113	408	1.6
	0.124	446	1.7
	0.134	482	1.8
	0.143	516	1.9
	0.152	549	2.0
	0.161	580	2.1
	0.170	611	2.2
	0.178	641	2.3
	0.186	671	2.4
	0.194	700	2.5
	0.202	728	2.6
	0.210	756	2.7
	0.218	783	2.8
	0.225	810	2.9
	0.232	835	3.0
	0.239	860	3.1
	0.245	883	3.2
	0.252	906	3.3
	0.257	927	3.4
	0.263	946	3.5
	0.268	965	3.6
	0.273	982	3.7
	0.277	998	3.8
	0.281	1010	3.9
	0.285	1020	4.0
	0.288	1040	4.1
	0.291	1050	4.2
	0.294	1060	4.3
	0.296	1070	4.4
	0.299	1080	4.5
	0.301	1080	4.6
	0.303	1090	4.7
	0.305	1100	4.8
	0.307	1100	4.9
	0.308	1110	5.0



05_c DYNAMIC BALANCING VALVES (PICV)

TIEMME-AUTO (DN25 LARGE - DN32 - DN40 - DN50)

GUIDE TO SELECTING EXTERNALLY-ADJUSTABLE CARTRIDGES

VALVE DN25 LARGE-DN32 FLOW RATE ADJUSTMENT
Cartridge adjustment using Tiemme key art. 6543CH.

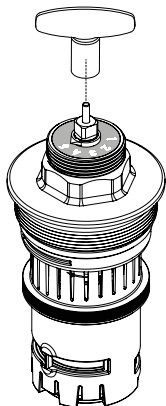

VALVE DN40 - DN50 FLOW RATE ADJUSTMENT
Cartridge adjustment using Tiemme key art. 6545CH.

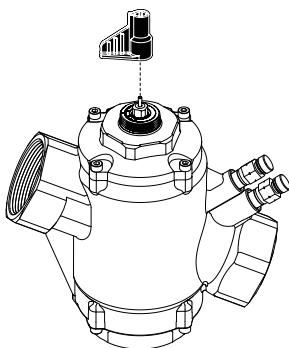

DN40 cartridge for Tiemme-Auto valves DN25 LARGE-DN32
Pressure range ΔP : 16-800 kPa

Nominal flow rate	l/sec	l/h	Setting
			Green 2
	0.240	865	1.0
	0.282	1010	1.1
	0.322	1160	1.2
	0.361	1300	1.3
	0.399	1430	1.4
	0.435	1570	1.5
	0.471	1700	1.6
	0.506	1820	1.7
	0.540	1940	1.8
	0.573	2060	1.9
	0.605	2180	2.0
	0.636	2290	2.1
	0.667	2400	2.2
	0.696	2510	2.3
	0.725	2610	2.4
	0.753	2710	2.5
	0.780	2810	2.6
	0.807	2900	2.7
	0.832	3000	2.8
	0.858	3090	2.9
	0.882	3180	3.0
	0.906	3260	3.1
	0.930	3350	3.2
	0.953	3430	3.3
	0.975	3510	3.4
	0.997	3590	3.5
	1.02	3670	3.6
	1.04	3740	3.7
	1.06	3820	3.8
	1.08	3890	3.9
	1.10	3960	4.0
	1.12	4030	4.1
	1.14	4100	4.2
	1.16	4170	4.3
	1.18	4240	4.4
	1.20	4300	4.5
	1.21	4370	4.6
	1.23	4440	4.7
	1.25	4500	4.8
	1.27	4570	4.9
	1.29	4630	5.0

DN20 cartridge for Tiemme-Auto DN40-DN50 Valves
Pressure range ΔP : 16-400 kPa

Nominal flow rate	l/sec	l/h	Setting
			Green 3
	0.528	1900	1.0
	0.633	2278	1.1
	0.738	2655	1.2
	0.843	3033	1.3
	0.947	3410	1.4
	1.05	3787	1.5
	1.16	4163	1.6
	1.26	4537	1.7
	1.36	4909	1.8
	1.47	5279	1.9
	1.57	5646	2.0
	1.67	6011	2.1
	1.77	6372	2.2
	1.87	6730	2.3
	1.97	7083	2.4
	2.06	7432	2.5
	2.16	7776	2.6
	2.25	8115	2.7
	2.35	8449	2.8
	2.44	8777	2.9
	2.53	9098	3.0
	2.61	9413	3.1
	2.70	9721	3.2
	2.78	10021	3.3
	2.86	10314	3.4
	2.94	10599	3.5
	3.02	10875	3.6
	3.10	11142	3.7
	3.17	11400	3.8
	3.24	11649	3.9
	3.30	11888	4.0
	3.37	12116	4.1
	3.43	12334	4.2
	3.48	12540	4.3
	3.54	12735	4.4
	3.59	12919	4.5
	3.64	13090	4.6
	3.68	13249	4.7
	3.72	13395	4.8
	3.76	13527	4.9
	3.79	13647	5.0

05_C DYNAMIC BALANCING VALVES (PICV)

TIEMME-EASY HIGH FLOW RATE

ADVANTAGES / STRENGTHS

- Keeps the flow rate accurately constant;
- Applicable on risers;
- Calibration with Tiemme key;

OPERATING CURVES

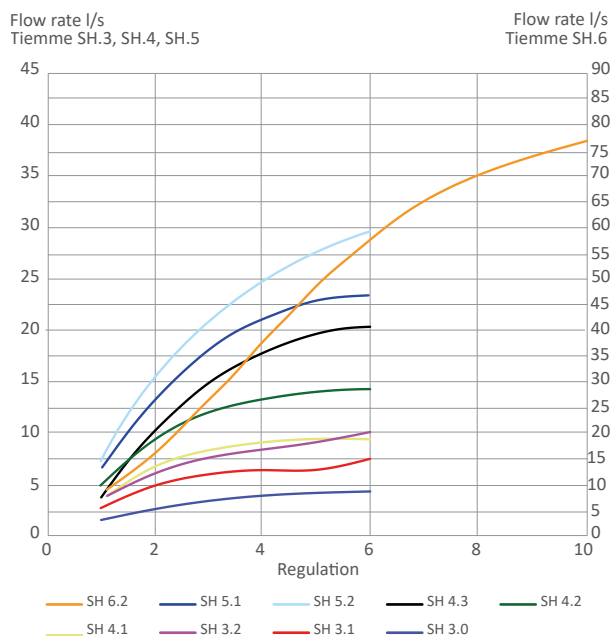

PRODUCT RANGE



6541DN

TIEMME-EASY HIGH FLOW RATE externally-adjustable flow rate stabilizer, with pressure plugs.

i Accessories: 6543CH - 6535ET
For codes see page 119

Code	Valve body	Model	Range ΔP	Flow rate l/h	Price €	Unit/Box
651 0722	DN65	SH 3.0-65	30 - 600 kPa	5310 - 15000		1/1
651 0723		SH 3.1-65	30 - 600 kPa	9240 - 25700		1/1
651 0824		SH 3.2-65	35 - 600 kPa	12800 - 35600		1/1
651 0825	DN80	SH 3.0-80	30 - 600 kPa	5310 - 15000		1/1
651 0826		SH 3.1-80	30 - 600 kPa	9240 - 25700		1/1
651 0724		SH 3.2-80	35 - 600 kPa	12800 - 35600		1/1
651 0827		SH 4.1-80	30 - 600 kPa	12600 - 33800		1/1
651 0828		SH 4.2-80	35 - 600 kPa	17000 - 51000		1/1
651 0829		SH 4.3-80	50 - 600 kPa	13300 - 72700		1/1
651 0830	DN100	SH 4.1-100	30 - 600 kPa	12600 - 33800		1/1
651 0831		SH 4.2-100	35 - 600 kPa	17000 - 51000		1/1
651 0739		SH 4.3-100	50 - 600 kPa	13300 - 72700		1/1
651 0832	DN125	SH 5.1-125	30 - 600 kPa	23300 - 83800		1/1
651 0725		SH 5.2-125	35 - 600 kPa	25600 - 106000		1/1
651 0741	DN150	SH 5.1-150	30 - 600 kPa	23300 - 83800		1/1
651 0743		SH 5.2-150	35 - 600 kPa	25600 - 106000		1/1
651 0745	DN200	SH 6.2-200	35 - 600 kPa	33100 - 277000		1/1
651 0833	DN250	SH 6.2-250	35 - 600 kPa	33100 - 277000		1/1



05_c DYNAMIC BALANCING VALVES (PICV)

TIEMME-EASY HIGH FLOW RATE (DN65 - DN80)

FLOW RATE SELECTION GUIDE

FLOW RATE ADJUSTMENT
Cartridge adjustment using
Tiemme key art. 6543CH.

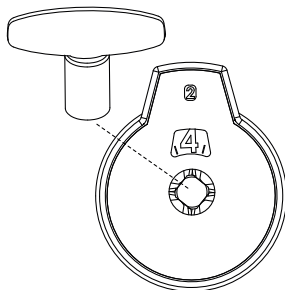

Valves DN65-DN80
Cartridge SH. 3.0
Pressure range ΔP : 30-600 kPa

l/sec	l/h	Setting
1.48	5310	1.0
1.58	5700	1.1
1.69	6080	1.2
1.79	6460	1.3
1.90	6830	1.4
2.00	7190	1.5
2.09	7540	1.6
2.19	7880	1.7
2.28	8220	1.8
2.37	8540	1.9
2.46	8860	2.0
2.55	9170	2.1
2.63	9470	2.2
2.71	9770	2.3
2.79	10100	2.4
2.87	10300	2.5
2.95	10600	2.6
3.02	10900	2.7
3.09	11100	2.8
3.16	11400	2.9
3.22	11600	3.0
3.29	11800	3.1
3.35	12000	3.2
3.41	12300	3.3
3.46	12500	3.4
3.52	12700	3.5
3.57	12900	3.6
3.62	13000	3.7
3.67	13200	3.8
3.72	13400	3.9
3.76	13500	4.0
3.80	13700	4.1
3.84	13800	4.2
3.88	14000	4.3
3.91	14100	4.4
3.94	14200	4.5
3.97	14300	4.6
4.00	14400	4.7
4.03	14500	4.8
4.05	14600	4.9
4.07	14700	5.0
4.09	14700	5.1
4.11	14800	5.2
4.12	14800	5.3
4.13	14900	5.4
4.14	14900	5.5
4.15	14900	5.6
4.16	15000	5.7
4.16	15000	5.8
4.16	15000	5.9
4.16	15000	6.0

Valves DN65-DN80
Cartridge SH. 3.1
Pressure range ΔP : 30-600 kPa

l/sec	l/h	Setting
2.57	9240	1.0
2.81	10100	1.1
3.05	11000	1.2
3.27	11800	1.3
3.49	12500	1.4
3.69	13300	1.5
3.88	14000	1.6
4.06	14600	1.7
4.23	15200	1.8
4.39	15800	1.9
4.54	16300	2.0
4.68	16900	2.1
4.82	17300	2.2
4.94	17800	2.3
5.06	18200	2.4
5.17	18600	2.5
5.28	19000	2.6
5.38	19400	2.7
5.47	19700	2.8
5.55	20000	2.9
5.63	20300	3.0
5.70	20500	3.1
5.77	20800	3.2
5.84	21000	3.3
5.90	21200	3.4
5.96	21400	3.5
6.01	21600	3.6
6.06	21800	3.7
6.10	22000	3.8
6.15	22100	3.9
6.19	22300	4.0
6.23	22400	4.1
6.27	22600	4.2
6.31	22700	4.3
6.35	22900	4.4
6.39	23000	4.5
6.42	23100	4.6
6.46	23300	4.7
6.50	23400	4.8
6.54	23500	4.9
6.58	23700	5.0
6.62	23800	5.1
6.67	24000	5.2
6.72	24200	5.3
6.77	24400	5.4
6.82	24600	5.5
6.88	24800	5.6
6.94	25000	5.7
7.01	25200	5.8
7.08	25500	5.9
7.15	25700	6.0

Valves DN65-DN80
Cartridge SH. 3.2
Pressure range ΔP : 35-600 kPa

l/sec	l/h	Setting
3.55	12800	1.0
3.85	13900	1.1
4.13	14900	1.2
4.41	15900	1.3
4.67	16800	1.4
4.92	17700	1.5
5.16	18600	1.6
5.38	19400	1.7
5.60	20200	1.8
5.81	20900	1.9
6.01	21600	2.0
6.19	22300	2.1
6.37	22900	2.2
6.54	23600	2.3
6.71	24100	2.4
6.86	24700	2.5
7.00	25200	2.6
7.14	25700	2.7
7.28	26200	2.8
7.40	26600	2.9
7.52	27100	3.0
7.63	27500	3.1
7.74	27900	3.2
7.84	28200	3.3
7.94	28600	3.4
8.03	28900	3.5
8.12	29200	3.6
8.20	29500	3.7
8.28	29800	3.8
8.36	30100	3.9
8.44	30400	4.0
8.51	30600	4.1
8.58	30900	4.2
8.65	31100	4.3
8.72	31400	4.4
8.78	31600	4.5
8.85	31900	4.6
8.91	32100	4.7
8.98	32300	4.8
9.04	32600	4.9
9.11	32800	5.0
9.18	33000	5.1
9.25	33300	5.2
9.32	33500	5.3
9.39	33800	5.4
9.46	34100	5.5
9.54	34300	5.6
9.62	34600	5.7
9.71	34900	5.8
9.79	35300	5.9
9.89	35600	6.0

Calibration accuracy $\pm 5\%$ of
controlled flow rate or $\pm 2\%$ of
maximum flow.

05_c DYNAMIC BALANCING VALVES (PICV)

TIMME-EASY HIGH FLOW RATE (DN80 - DN100)

FLOW RATE SELECTION GUIDE

FLOW RATE ADJUSTMENT
Cartridge adjustment using
Tiemme key art. 6543CH.

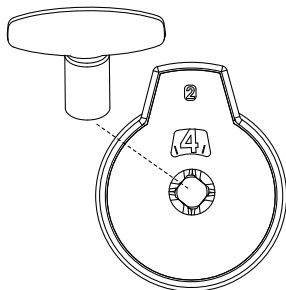

Valves DN80-DN100
Cartridge SH. 4.1
Pressure range ΔP : 30-600 kPa

l/sec	l/h	Setting
3.49	12600	1.0
3.88	14000	1.1
4.26	15300	1.2
4.61	16600	1.3
4.94	17800	1.4
5.26	18900	1.5
5.56	20000	1.6
5.84	21000	1.7
6.11	22000	1.8
6.36	22900	1.9
6.60	23800	2.0
6.82	24600	2.1
7.03	25300	2.2
7.23	26000	2.3
7.41	26700	2.4
7.58	27300	2.5
7.73	27800	2.6
7.88	28400	2.7
8.01	28800	2.8
8.14	29300	2.9
8.25	29700	3.0
8.35	30100	3.1
8.45	30400	3.2
8.53	30700	3.3
8.61	31000	3.4
8.68	31300	3.5
8.74	31500	3.6
8.80	31700	3.7
8.85	31900	3.8
8.90	32000	3.9
8.93	32200	4.0
8.97	32300	4.1
9.00	32400	4.2
9.03	32500	4.3
9.05	32600	4.4
9.07	32600	4.5
9.09	32700	4.6
9.10	32800	4.7
9.12	32800	4.8
9.13	32900	4.9
9.15	32900	5.0
9.16	33000	5.1
9.18	33000	5.2
9.19	33100	5.3
9.21	33200	5.4
9.23	33200	5.5
9.25	33300	5.6
9.28	33400	5.7
9.31	33500	5.8
9.34	33600	5.9
9.38	33800	6.0

Valves DN80-DN100
Cartridge SH. 4.2
Pressure range ΔP : 35-600 kPa

l/sec	l/h	Setting
4.73	17000	1.0
5.29	19000	1.1
5.82	21000	1.2
6.33	22800	1.3
6.82	24500	1.4
7.28	26200	1.5
7.72	27800	1.6
8.14	29300	1.7
8.54	30700	1.8
8.91	32100	1.9
9.27	33400	2.0
9.61	34600	2.1
9.93	35700	2.2
10.2	36800	2.3
10.5	37800	2.4
10.8	38800	2.5
11.0	39700	2.6
11.3	40500	2.7
11.5	41300	2.8
11.7	42000	2.9
11.9	42700	3.0
12.0	43400	3.1
12.2	43900	3.2
12.4	44500	3.3
12.5	45000	3.4
12.6	45500	3.5
12.7	45900	3.6
12.9	46300	3.7
13.0	46700	3.8
13.1	47000	3.9
13.1	47300	4.0
13.2	47600	4.1
13.3	47800	4.2
13.4	48100	4.3
13.4	48300	4.4
13.5	48500	4.5
13.5	48700	4.6
13.6	48800	4.7
13.6	49000	4.8
13.7	49200	4.9
13.7	49300	5.0
13.7	49500	5.1
13.8	49600	5.2
13.8	49800	5.3
13.9	49900	5.4
13.9	50100	5.5
14.0	50200	5.6
14.0	50400	5.7
14.1	50600	5.8
14.1	50800	5.9
14.2	51000	6.0

Valves DN80-DN100
Cartridge SH. 4.3
Pressure range ΔP : 50-600 kPa

l/sec	l/h	Setting
3.68	13300	1.0
4.42	15900	1.1
5.13	18500	1.2
5.82	21000	1.3
6.50	23400	1.4
7.15	25700	1.5
7.78	28000	1.6
8.39	30200	1.7
8.99	32400	1.8
9.56	34400	1.9
10.1	36400	2.0
10.7	38400	2.1
11.2	40200	2.2
11.7	42100	2.3
12.2	43800	2.4
12.6	45500	2.5
13.1	47100	2.6
13.5	48700	2.7
13.9	50200	2.8
14.3	51600	2.9
14.7	53000	3.0
15.1	54300	3.1
15.4	55600	3.2
15.8	56800	3.3
16.1	58000	3.4
16.4	59100	3.5
16.7	60200	3.6
17.0	61200	3.7
17.3	62100	3.8
17.5	63000	3.9
17.8	63900	4.0
18.0	64700	4.1
18.2	65500	4.2
18.4	66200	4.3
18.6	66900	4.4
18.8	67600	4.5
18.9	68200	4.6
19.1	68700	4.7
19.2	69200	4.8
19.4	69700	4.9
19.5	70200	5.0
19.6	70600	5.1
19.7	70900	5.2
19.8	71300	5.3
19.9	71600	5.4
20.0	71900	5.5
20.0	72100	5.6
20.1	72300	5.7
20.1	72500	5.8
20.2	72600	5.9
20.2	72700	6.0

Calibration accuracy $\pm 5\%$ of
controlled flow rate or $\pm 2\%$ of
maximum flow.



05_c DYNAMIC BALANCING VALVES (PICV)

TIMME-EASY HIGH FLOW RATE (DN125 - DN150)

FLOW RATE SELECTION GUIDE

FLOW RATE ADJUSTMENT
Cartridge adjustment using
Tiemme key art. 6543CH.

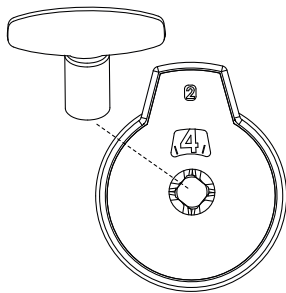

Valves DN125-DN150
Cartridge SH. 5.1
Pressure range ΔP : 30-600 kPa

l/sec	l/h	Setting
6.48	23300	1.0
7.24	26100	1.1
7.98	28700	1.2
8.69	31300	1.3
9.39	33800	1.4
10.1	36200	1.5
10.7	38600	1.6
11.4	40900	1.7
12.0	43100	1.8
12.6	45200	1.9
13.1	47300	2.0
13.7	49300	2.1
14.2	51200	2.2
14.7	53100	2.3
15.3	54900	2.4
15.7	56600	2.5
16.2	58300	2.6
16.6	59900	2.7
17.1	61500	2.8
17.5	63000	2.9
17.9	64400	3.0
18.3	65800	3.1
18.6	67100	3.2
19.0	68300	3.3
19.3	69500	3.4
19.6	70700	3.5
19.9	71700	3.6
20.2	72800	3.7
20.5	73800	3.8
20.7	74700	3.9
21.0	75600	4.0
21.2	76400	4.1
21.4	77200	4.2
21.6	77900	4.3
21.8	78600	4.4
22.0	79200	4.5
22.2	79800	4.6
22.3	80300	4.7
22.5	80800	4.8
22.6	81300	4.9
22.7	81700	5.0
22.8	82100	5.1
22.9	82400	5.2
23.0	82700	5.3
23.0	83000	5.4
23.1	83200	5.5
23.2	83400	5.6
23.2	83500	5.7
23.2	83600	5.8
23.3	83700	5.9
23.3	83800	6.0

Valves DN125-DN150
Cartridge SH. 5.2
Pressure range ΔP : 35-600 kPa

l/sec	l/h	Setting
7.10	25600	1.0
8.06	29000	1.1
8.98	32300	1.2
9.87	35500	1.3
10.7	38600	1.4
11.6	41600	1.5
12.4	44500	1.6
13.1	47300	1.7
13.9	50000	1.8
14.6	52600	1.9
15.3	55100	2.0
16.0	57500	2.1
16.6	59800	2.2
17.2	62100	2.3
17.8	64200	2.4
18.4	66300	2.5
19.0	68300	2.6
19.5	70200	2.7
20.0	72100	2.8
20.5	73800	2.9
21.0	75500	3.0
21.4	77200	3.1
21.9	78700	3.2
22.3	80200	3.3
22.7	81700	3.4
23.1	83100	3.5
23.4	84400	3.6
23.8	85700	3.7
24.1	86900	3.8
24.5	88100	3.9
24.8	89200	4.0
25.1	90300	4.1
25.4	91400	4.2
25.7	92400	4.3
25.9	93400	4.4
26.2	94300	4.5
26.5	95200	4.6
26.7	96100	4.7
26.9	97000	4.8
27.2	97800	4.9
27.4	98600	5.0
27.6	99400	5.1
27.8	100000	5.2
28.1	101000	5.3
28.3	102000	5.4
28.5	102000	5.5
28.7	103000	5.6
28.9	104000	5.7
29.1	105000	5.8
29.3	105000	5.9
29.5	106000	6.0

Calibration accuracy $\pm 5\%$ of
controlled flow rate or $\pm 2\%$ of
maximum flow.

05_c DYNAMIC BALANCING VALVES (PICV)

TIMME-EASY HIGH FLOW RATE (DN200 - DN250)

FLOW RATE SELECTION GUIDE

FLOW RATE ADJUSTMENT

Cartridge adjustment using
Tiemme key art. 6543CH.

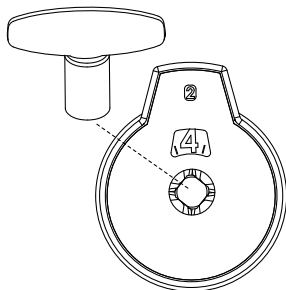

Valves DN200-DN250
Cartridge SH. 6.2
Pressure range ΔP : 35-600 kPa

l/sec	l/h	Setting	l/sec	l/h	Setting
9.21	33100	1.0	58.3	210000	6.1
9.69	34900	1.1	59.1	213000	6.2
10.2	36800	1.2	59.8	215000	6.3
10.8	38900	1.3	60.6	218000	6.4
11.5	41200	1.4	61.3	221000	6.5
12.1	43700	1.5	62.0	223000	6.6
12.9	46300	1.6	62.7	226000	6.7
13.6	49100	1.7	63.4	228000	6.8
14.5	52000	1.8	64.0	230000	6.9
15.3	55100	1.9	64.6	233000	7.0
16.2	58200	2.0	65.2	235000	7.1
17.1	61500	2.1	65.8	237000	7.2
18.0	64900	2.2	66.4	239000	7.3
19.0	68400	2.3	66.9	241000	7.4
20.0	71900	2.4	67.4	243000	7.5
21.0	75600	2.5	68.0	245000	7.6
22.0	79300	2.6	68.4	246000	7.7
23.1	83100	2.7	68.9	248000	7.8
24.1	86900	2.8	69.4	250000	7.9
25.2	90800	2.9	69.8	251000	8.0
26.3	94700	3.0	70.2	253000	8.1
27.4	98700	3.1	70.6	254000	8.2
28.5	103000	3.2	71.0	256000	8.3
29.6	107000	3.3	71.4	257000	8.4
30.8	111000	3.4	71.8	258000	8.5
31.9	115000	3.5	72.1	260000	8.6
33.0	119000	3.6	72.5	261000	8.7
34.2	123000	3.7	72.8	262000	8.8
35.3	127000	3.8	73.2	263000	8.9
36.4	131000	3.9	73.5	265000	9.0
37.5	135000	4.0	73.8	266000	9.1
38.6	139000	4.1	74.2	267000	9.2
39.8	143000	4.2	74.5	268000	9.3
40.9	147000	4.3	74.8	269000	9.4
41.9	151000	4.4	75.1	270000	9.5
43.0	155000	4.5	75.5	272000	9.6
44.1	159000	4.6	75.8	273000	9.7
45.2	163000	4.7	76.1	274000	9.8
46.2	166000	4.8	76.5	275000	9.9
47.2	170000	4.9	76.8	277000	10.0
48.3	174000	5.0			
49.3	177000	5.1			
50.2	181000	5.2			
51.2	184000	5.3			
52.2	188000	5.4			
53.1	191000	5.5			
54.0	194000	5.6			
54.9	198000	5.7			
55.8	201000	5.8			
56.6	204000	5.9			
57.5	207000	6.0			

Calibration accuracy $\pm 5\%$ of
controlled flow rate or $\pm 2\%$ of
maximum flow.



05_c DYNAMIC BALANCING VALVES (PICV)

TIEMME-AUTO HIGH FLOW RATE

ADVANTAGES / STRENGTHS

- Self-calibrating actuators;
- Keeps the flow rate accurately constant;
- Applicable on risers;
- Potential for an analogue 0-10 V or 4/20 mA or digital 2-position 3-point adjustment;
- Supplied with servomotor.

OPERATING CURVES

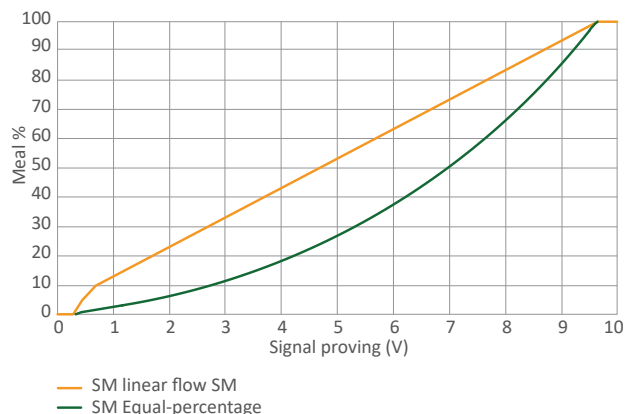

PRODUCT RANGE



6544DN

TIEMME-AUTO HIGH FLOW RATE dynamic balancing valves equipped with servomotor, with pressure plugs

i Accessories: 6535ET
Spare parts: 6544DNSERV
For codes see page 119

Code	Valve body	Model	Range ΔP	Flow rate l/h	Price €	Unit/Box
651 0834	DN65	SM 3.0-65	30 - 800 kPa	5310 - 15000		1/1
651 0835		SM 3.1-65	30 - 800 kPa	9240 - 25700		1/1
651 0836		SM 3.2-65	35 - 800 kPa	12800 - 35600		1/1
651 0837	DN80	SM 3.0-80	30 - 800 kPa	5310 - 15000		1/1
651 0838		SM 3.1-80	30 - 800 kPa	9240 - 25700		1/1
651 0839		SM 3.2-80	35 - 800 kPa	12800 - 35600		1/1
651 0840		SM 4.1-80	30 - 800 kPa	12600 - 33800		1/1
651 0841	DN100	SM 4.2-80	35 - 800 kPa	17000 - 51000		1/1
651 0842		SM 4.3-80	50 - 800 kPa	13300 - 72700		1/1
651 0843		SM 4.1-100	30 - 800 kPa	12600 - 33800		1/1
651 0844	DN125	SM 4.2-100	35 - 800 kPa	17000 - 51000		1/1
651 0845		SM 4.3-100	50 - 800 kPa	13300 - 72700		1/1
651 0846	DN150	SM 5.1-125	30 - 800 kPa	23300 - 83800		1/1
651 0847		SM 5.2-125	35 - 800 kPa	25600 - 106000		1/1
651 0848	DN200	SM 5.1-150	30 - 800 kPa	23300 - 83800		1/1
651 0849		SM 5.2-150	35 - 800 kPa	25600 - 106000		1/1
651 0850	DN250	SM 6.2-200	35 - 800 kPa	33100 - 277000		1/1
651 0851	DN250	SM 6.2-250	35 - 800 kPa	33100 - 277000		1/1

Balancing valves with Tiemme differential pressure control art. 6538 are compact valves designed for differential pressure control at various points in the system. Thanks to the combined action of diaphragm and spring, they are able to react to the pressure variations generated within the system, keeping the pressure difference across the circuit constant at the set value. This adjustment is ideal for maintaining balanced variable flow systems, such as thermostatic valve systems, utility satellites or manifold systems with multi-zone control. The partner valve art. 6539 is the perfect complement to the differential pressure regulator because it allows balancing of the maximum circulating design flow rate, transmission of the supply to the regulator, measurement of the pressure differences involved and interception of the branch with position memory.

WHAT ARE BALANCING VALVES WITH DIFFERENTIAL PRESSURE CONTROL USED FOR?

Systems sized to the maximum design capacity only work in this condition for short periods. Thermostatic head or servomotor intervention causes a continuous change of utility flow rate demand. Differential pressure control becomes essential to ensure better system management and performance optimization against variable flow rates, preventing issues of system noise.

One of the main issues of heating systems is suboptimal hydronic balance, due to differential pressure changing constantly and unpredictably. This is often a cause for user complaints due to insufficient heating, noise and high energy consumption. To solve these issues, often more powerful pumps are installed to improve circulation along the distribution network. Unfortunately, this has a negative effect on the differential pressure, causing noise issues and an increase in energy consumption, with an accompanying fall in system efficiency.

Balancing valves with Tiemme differential pressure control ensure an optimum pressure differential for the control valve operation and a correct and constant flow rate in individual risers. This is why DIN 18380 requires differential pressure control in case of partial load. Valves with Tiemme differential pressure control automatically create an optimal hydronic balance within the system both in partial and total load conditions, through constant balancing while in operation, and may also be used for cooling applications (fan convectors, chilled beams, etc.).

The installation of balancing valves with differential pressure control therefore ensures:

- **Increased reliability:** Valves make the system more reliable, resolving issues such as noisy radiators, insufficient heating of rooms at a distance from the heat source or overheating of rooms close to the heat source.
- **Improved dwelling comfort:** The valves offer stable pressure conditions for the radiator or underfloor heating regulating valves, allowing better regulation of the ambient temperature.
- **Reduced energy consumption:** Higher energy efficiency results from more precise temperature regulation and the elimination of overheating. A suitable balance prevents an excessive flow rate and the resulting low temperature of the return water, improving the energy efficiency of

condensing boilers and district heating systems.

- **Design simplicity:** The valves divide the piping system into independent pressure zones, usually single risers or apartments, making it no longer necessary to use complex calculations for commissioning. This allows zones to be gradually connected to the water mains without the need for an additional balancing method.
- **Ease of use:** The new generation of balancing valves with differential pressure control is even easier to use thanks to the possibility of external regulation even when the system is working, which guarantees shorter commissioning times.
- **Various fields of application:** TIEMME offers several items in order to satisfy any system requirement for installation on risers, inside individual boxes within dwelling units or in boxes connected to the distribution manifolds of the high or low temperature systems.

ADVANTAGES / STRENGTHS

- Ensures better system management and optimization of thermal performance;
- Prevents noise and high speed issues in variable capacity systems;
- Ideal solution for systems with variable capacity;
- It allows external adjustment even when the system is running.

INSTALLATION

The hydraulic system is regulated by the combined action of two devices, the ΔP control valve art. 6538 installed on the system return line and the control/calibration device art. 6539 (commonly referred to as "partner valve") installed on the supply line. The two devices are connected to each other via a copper capillary.

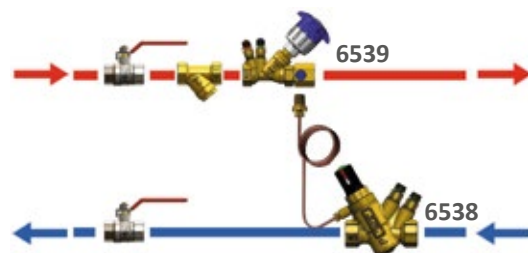

The ΔP control valve acts proportionally to re-establish the default differential pressure value when the flow rate varies (e.g. due to the closure of certain circuits/operation of thermostatic valves etc.). The balancing diaphragm (system fulcrum), located inside the cartridge of the valve itself, as a result of the pressure variation modulates the ΔP by expanding and contracting so as to return it to the predefined value.



05_D BALANCING VALVES WITH DIFFERENTIAL PRESSURE CONTROL (DPCV)

Diagram 1: Riser balancing function

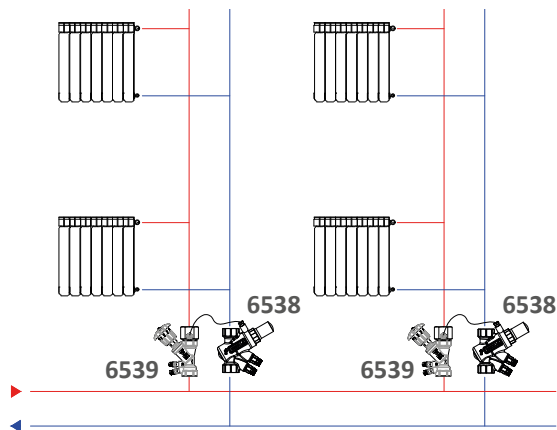
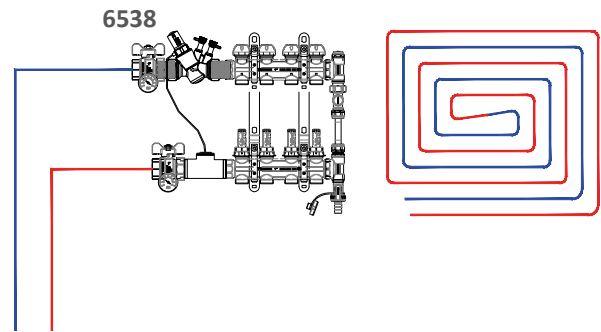

Diagram 2: Manifold balancing function



PRODUCT RANGE



6538

Balancing valve with differential pressure control

i Accessories: 6543CH - 6539 - 6535ET
Spare parts: 6542PP
For codes see page 119

Code	Valve body	Cartridge size	Range ΔP	Flow rate l/h	Price €	Unit/Box
651 0626	1/2" (DN15)	DN20	5 - 50 kPa	15 - 2000		1/10
651 0627	3/4" (DN20)	DN20	5 - 50 kPa	15 - 2000		1/10
651 0628	1" (DN25 small)	DN20	5 - 50 kPa	15 - 2000		1/10
651 0898	1" (DN25 large)	DN40	5 - 60 kPa	15 - 5980		1/10
651 0629	1"1/4 (DN32)	DN40	5 - 60 kPa	15 - 5980		1/10
651 0630	1"1/2 (DN40)	DN50	5 - 100 kPa	200 - 14000		1/1
651 0631	2" (DN50)	DN50	5 - 100 kPa	200 - 14000		1/1



6539

Balancing valve with capillary tube fitting

i Accessories: 6535ET
Spare parts: 6535PP
For codes see page 119

Code	Type	Price €	Unit/Box
651 0632	1/2"		1/5
651 0633	3/4"		1/5
651 0634	1"		1/5
651 0635	1"1/4		1/5
651 0636	1"1/2		1/1
651 0637	2"		1/1

05_D BALANCING VALVES WITH DIFFERENTIAL PRESSURE CONTROL (DPCV)

(DN15-DN20-DN25 SMALL)

FLOW RATE SELECTION GUIDE

DN20 cartridge - for valve DN15-DN20-DN25 Small - Pressure range ΔP : 5-50 kPa

ΔP (kPa)	Setting														
	1	1.2	1.4	1.6	1.8	2	2.2	2.4	2.6	2.8	3	3.5	4	4.5	5
3	330	430	520	620	710	810	920	1030	1150	1270	1390	1690	1970		
4	260	370	470	560	660	760	870	980	1100	1220	1340	1640	1920		
5	190	310	410	510	610	710	820	930	1050	1170	1290	1590	1870		
6	120	240	350	460	560	660	770	880	1000	1120	1240	1540	1820		
7	50	180	300	400	510	610	720	830	950	1070	1190	1490	1770		
8	15	120	240	350	460	560	670	780	900	1020	1140	1440	1720	1990	
9		60	190	300	410	510	620	740	850	970	1090	1390	1670	1940	
10		15	130	240	350	460	570	690	800	920	1040	1340	1620	1890	
11			70	190	300	410	520	640	750	870	990	1290	1570	1840	
12			15	140	250	360	470	590	700	820	940	1240	1520	1790	
13				90	200	310	420	540	650	770	890	1190	1470	1740	
14				30	150	260	370	490	600	720	840	1140	1420	1690	2000
15				15	100	210	320	440	550	670	790	1090	1370	1640	1950
16					50	160	280	390	500	620	740	1040	1320	1590	1900
17					15	110	230	340	450	570	690	990	1270	1540	1850
18						60	180	290	410	520	640	940	1220	1490	1800
19						15	130	240	360	470	590	890	1170	1440	1750
20							80	190	310	420	540	840	1120	1390	1700
21							30	140	260	370	490	780	1070	1340	1650
22							15	90	210	320	440	730	1020	1290	1600
23								40	160	270	390	680	970	1240	1550
24								15	110	220	340	630	920	1190	1500
25									60	170	290	580	870	1140	1450
26									15	120	240	530	820	1100	1400
27										70	190	480	770	1050	1350
28										20	140	430	720	1000	1300
29										15	90	380	670	950	1250
30											40	330	620	900	1200
31											15	280	570	850	1150
32												230	520	800	1100
33												180	470	750	1050
34												130	420	700	1000
35												80	370	650	950
36												30	320	600	900
37												15	270	550	850
38													220	500	800
39													170	450	750
40													120	400	700
41													70	350	650
42													15	300	600
43														250	550
44														200	500
45														150	450
46														110	400
47														60	350
48														15	300
49															250
50															200
51															150
52															100
53															50
54															15



05_D BALANCING VALVES WITH DIFFERENTIAL PRESSURE CONTROL (DPCV)

(DN25 LARGE - DN32)

FLOW RATE SELECTION GUIDE

DN40 cartridge - for DN25 large-DN32 Valve - Pressure Range ΔP : 5-60 kPa

ΔP (kPa)	Setting														
	1	1.2	1.4	1.6	1.8	2	2.2	2.4	2.6	2.8	3	3.5	4	4.5	5
5	1720	1720	1720	2010	2480	2970	3490	4030	4590	5190	5820				
6	1400	1400	1430	1870	2340	2830	3340	3870	4440	5030	5650				
7	1090	1090	1290	1730	2190	2680	3190	3720	4280	4870	5490				
8	780	780	1150	1590	2050	2530	3030	3560	4120	4700	5320				
9	470	600	1020	1450	1910	2380	2880	3410	3960	4540	5150				
10	150	460	880	1310	1760	2240	2730	3250	3800	4380	4990				
11	15	330	740	1170	1620	2090	2580	3100	3640	4220	4820				
12		190	600	1030	1480	1940	2430	2950	3490	4050	4650				
13		60	470	890	1330	1800	2280	2790	3330	3890	4490				
14		15	330	750	1190	1650	2130	2640	3170	3730	4320	5940			
15			190	610	1040	1500	1980	2480	3010	3570	4150	5760			
16			50	470	900	1350	1830	2330	2850	3400	3990	5580			
17			15	330	760	1210	1680	2170	2690	3240	3820	5400			
18				190	610	1060	1530	2020	2540	3080	3650	5230			
19				50	470	910	1380	1870	2380	2920	3490	5050			
20				15	330	770	1230	1710	2220	2750	3320	4870			
21					180	620	1080	1560	2060	2590	3150	4690			
22					40	470	930	1400	1900	2430	2990	4510			
23					15	330	780	1250	1750	2270	2820	4330			
24						180	630	1090	1590	2110	2650	4150	5890		
25						30	470	940	1430	1940	2490	3980	5690		
26						15	320	790	1270	1780	2320	3800	5500		
27							170	630	1110	1620	2150	3620	5310		
28							15	480	950	1460	1990	3440	5120		
29								320	800	1290	1820	3260	4930		
30								170	640	1130	1650	3080	4730		
31								15	480	970	1490	2900	4540		
32									320	810	1320	2720	4350		
33									160	640	1150	2550	4160		
34									15	480	980	2370	3960	5830	
35										320	820	2190	3770	5620	
36										160	650	2010	3580	5410	
37										15	480	1830	3390	5200	
38											320	1650	3190	4990	
39											150	1470	3000	4780	
40											15	1300	2810	4580	
41												1120	2620	4370	
42												940	2420	4160	
43												760	2230	3950	5980
44												580	2040	3740	5750
45												400	1850	3530	5530
46												220	1660	3330	5300
47												50	1460	3120	5070
48												15	1270	2910	4840
49													1080	2700	4620
50													890	2490	4390
51													690	2280	4160
52													500	2080	3930
53													310	1870	3710
54													120	1660	3480
55													15	1450	3250
56														1240	3030
57														1030	2800
58														830	2570
59														620	2340
60														410	2120
61														200	1890
62														15	1660
63															1430
64															1210
65															980
66															750
67															530
68															300
69															70
70															15

05_D BALANCING VALVES WITH DIFFERENTIAL PRESSURE CONTROL (DPCV)

(DN40 - DN50)

FLOW RATE SELECTION GUIDE

DN50 cartridge - for DN40-DN50 valve - Pressure range ΔP : 5-100 kPa

ΔP (kPa)	Setting														
	1	1.2	1.4	1.6	1.8	2	2.2	2.4	2.6	2.8	3	3.5	4	4.5	5
5	3670	3670	3670	3670	3900	5550	7130	8920	11000						
10	1670	1670	1670	1720	2830	4300	5800	7490	9400	11700					
12	870	900	920	1350	2400	3800	5270	6930	8800	11000	13600				
14	200	370	520	980	1970	3300	4730	6360	8200	10400	12900				
16			200	610	1550	2800	4200	5790	7610	9700	12200				
18				230	1120	2300	3670	5220	7000	9100	11500				
20					690	1800	3140	4650	6390	8400	10800				
22					260	1300	2610	4090	5780	7740	10000				
24						800	2070	3520	5170	7090	9300				
26						300	1540	2950	4560	6430	8600				
28							1010	2380	3950	5770	7900	13400			
30							480	1810	3340	5110	7190	12600			
32								1240	2730	4460	6470	11900			
34								680	2120	3800	5760	11100			
36								200	1510	3140	5050	10300			
38									900	2480	4330	9600			
40									290	1820	3620	8800			
42										1170	2900	8100	13900		
44										510	2190	7320	13100		
46											1470	6570	12300		
48											760	5810	11500		
50											200	5060	10700		
52												4300	9870		
54												3550	9070		
56												2790	8270	13600	
58												2040	7470	12800	
60												1280	6670	12100	
62												530	5870	11400	
64													5070	10700	
66													4270	9900	
68													3470	9200	14000
70													2670	8500	13300
72													1870	7740	12600
74													1070	7020	12000
76													270	6290	11300
78														5560	10600
80														4830	10000
82														4110	9300
84														3380	8600
86														2650	7970
88														1930	7300
90														1200	6640
92														470	5970
94															5300
96															4640
98															3970
100															3300
102															2640
104															1970
106															1300
108															640



05E BALANCING VALVES WITH DIFFERENTIAL PRESSURE CONTROL (PIBCV)

The Tiemme differential pressure control valves art. 6540, are compact valves designed for differential pressure control at different points of the system, in particular for flow control on multi-zone radiant system manifolds, thermostatic valve systems and utility satellites.

Thanks to the combined action of a membrane and a spring, they are able to perform three functions:

1. Reacting to the variations generated in the system, keeping the pressure difference across the circuit constant at the set value.
2. Setting the circuit maximum flow rate (design flow rate) via the adjustment ring on the top of the valve.
3. Opening/closing/regulating the flow with the installation of the electrothermal actuator art. 6542ATT (optional).

Pressure Independent Balancing and Control Valves (PIBCV) are the latest development in balancing and control solutions. Successfully introduced to the market to become standard in many heating and air conditioning systems, ensuring accuracy and lower system running costs.

By combining three functions in a single valve, savings are made compared to the purchase of individual components, and installation time reduced.

ADVANTAGES / STRENGTHS

- Differential pressure regulator function;
- Flow rate limiter function;
- Linear control valve function;
- Compact body for installation in boxes or tight spaces.

INSTALLATION

The balancing valve with differential pressure control (art. 6540) must be installed on the return line of the system, paying attention to the arrow on the body.

They can be installed in both horizontal and vertical positions. On the supply line we suggest the installation of fittings art. 1570 + art. 1581 preceded by a filter to protect the system from possible impurities.

The capillary tube must be connected to the supply branch via a 1/4" adapter.

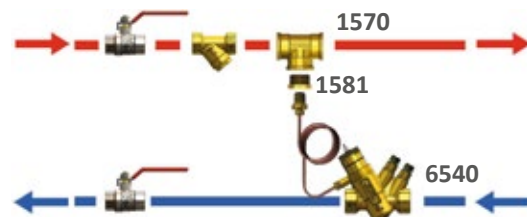
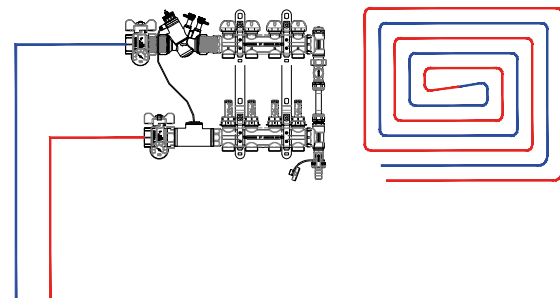

Diagram 1: Manifold balancing function



05E BALANCING VALVES WITH DIFFERENTIAL PRESSURE CONTROL (PIBCV)

PRODUCT RANGE



6540

Balancing valve with differential pressure control and on/off actuator



Accessories: 6543CH - 6542ATT - 6535ET
Spare parts: 6542PP
For codes see page 119

Code	Type	Range ΔP	Flow rate l/h	Price €	Unit/Box
651 0920	1/2"	3 - 17 kPa	9 - 680		1/10
651 0921	3/4"	3 - 17 kPa	9 - 680		1/10
651 0922	1"	3 - 17 kPa	9 - 680		1/10

FLOW RATE SELECTION GUIDE

For valves 1/2"-3/4"-1" - Pressure range ΔP: 3-17 kPa

ΔP (kPa)	Setting														
	1.0	1.2	1.4	1.6	1.8	2.0	2.2	2.4	2.6	2.8	3.0	3.5	4.0	4.5	5.0
3	84	120	170	230	280	330	370	400	420	450	470	550	610	630	680
4	79	110	160	210	260	310	340	370	390	420	440	510	570	590	630
5	73	100	150	190	240	290	320	340	360	380	410	470	520	540	590
6	67	96	130	180	220	260	290	320	330	350	380	440	480	500	540
7	61	88	120	160	200	240	270	290	310	320	340	400	440	460	490
8	55	79	110	150	190	220	240	260	280	290	310	360	400	410	450
9	50	71	99	130	170	190	220	230	250	260	280	320	360	370	400
10	44	63	88	120	150	170	190	210	220	230	250	280	320	330	350
11	38	54	76	100	130	150	170	180	190	200	210	250	270	280	310
12	32	46	64	86	110	130	140	150	160	170	180	210	230	240	260
13	26	38	53	70	88	100	120	120	130	140	150	170	190	200	210
14	21	30	41	55	69	81	90	97	100	110	120	130	150	150	170
15	15	21	30	39	49	58	65	70	74	78	83	96	110	110	120
16	12	17	24	32	40	47	52	56	59	63	66	77	86	88	96
17	9	13	18	24	30	35	39	42	45	47	50	58	65	67	72

FLOW RATE ADJUSTMENT

Cartridge adjustment using suitable Tiemme key art. 6543CH.

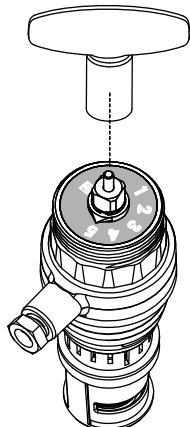



6535ISOL
Foam PEX insulation for balancing valve 6535G

i For valve 6535G

Code	Type	Price €	Unit/Box
651 0229	1/2"		1/10
651 0230	3/4"		1/10
651 0231	1"		1/10
651 0232	1"1/4		1/10
651 0233	1"1/2		1/10
651 0234	2"		1/10



6535DNISOL
Closed cell expanded PEX insulation for balancing valve 6535DN

i For valve 6535DN

Code	Type	Price €	Unit/Box
651 0275	DN65		1/1
651 0276	DN80		1/1
651 0277	DN100		1/1
651 0278	DN125		1/1
651 0279	DN150		1/1
651 0280	DN200		1/1



6535DNMANOP
Knob for balancing valves 6535DN

i For valve 6535DN

Code	Type	Price €	Unit/Box
651 0281	DN65 - DN150		1/1
651 0282	DN200		1/1



6535PP
Pair of red and blue pressure plugs

i For valves 6535G - 6535DN - 6539

Code	Type	Price €	Unit/Box
651 0235	1/4"		10/60



6542PP
Pressure plug balancing valves.

i For valves 6541CC - 6542CC - 6542CCS - 6538 -

Code	Type	Price €	Unit/Box
651 0706	1/4"		20/120



6543CH
Adjustment key for externally-adjustable cartridges

i For 6542CC - 6542CCS valves (Green 0 - Green 1 - Green 2) - 6541DN - 6538 - 6540

Code	Type	Price €	Unit/Box
651 0708	-		1/10



6545CH
Adjusting key for TIEMME-AUTO balancing valve DN40 - DN50

i For valve 6542CCS (Green 3)

Code	Type	Price €	Unit/Box
651 0870	-		1/10



6542ATT

Electrothermal actuator for TIEMME-AUTO balancing valve. Fitting M30x1.5

i For 6542CCS valve (Green 0 - Green 1 - Green 2) - 6540

Code	Type	Price €	Unit/Box
651 0814	NC; on/off (230 VAC)		1/1
651 0815	NC; on/off (24 VAC)		1/1
651 0816	NC; 0÷10V (24 VAC)		1/1



6542SERV

Electric servomotor for balancing valve TIEMME-AUTO. Fitting M30 x 1,5

i For valve 6542CCS (Green 0 - Green 1 - Green 2)

Code	Type	Price €	Unit/Box
651 0817	2-position, 3-point adjustment (230V AC)		1/1
651 0819	0-10 V (24V AC)		1/1



6542SERV2

Electric servomotor for balancing valve TIEMME-AUTO DN40 - DN50. Fitting M30 x 1.5

i For valve 6542CCS (Green 3)

Code	Type	Price €	Unit/Box
651 0818	2-position, 3-point adjustment 0-10 V (24V AC)		1/1



6544DNSERV

Axial servomotor for balancing valve art. 6544DN with quick-coupling fitting

i For valve 6544DN

Code	Type	Price €	Unit/Box
651 0871	Analogue adjustment 0-10 V or 4/20 mA or digital adjustment 2-position 3-point		1/1



6536

Digital differential pressure meter for differential pressure measurement and the calculation of the flow rate

Code	Type	Price €	Unit/Box
651 0237	-		1/5

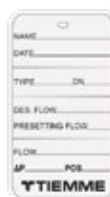

6535ET

Label for recording valve setting data

i Supplied with metal retaining ring

Code	Type	Price €	Unit/Box
651 0236	-		10/100



05_G MULTIFUNCTION KIT FOR AIR TERMINAL UNITS

The multifunction kit art. 3162 allows adjustment, commissioning and flushing/servicing of terminal units (fan convectors, fan coils etc) within a heating, ventilation and air-conditioning system.

The kit should be installed upstream of the terminal unit and includes the main components necessary for proper operation.

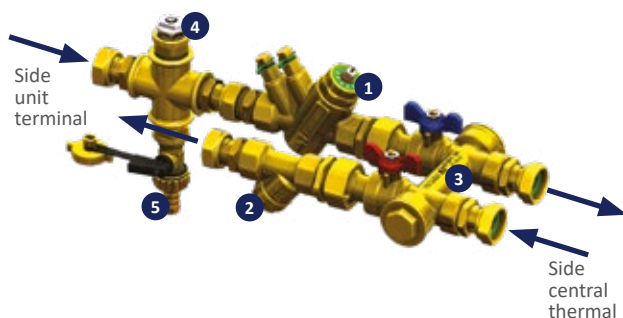

1. Dynamic balancing valve (PICV)
2. Strainer (filtration grade 350 µm)
3. Bypass assembly
4. Manual air vent valve
5. Drain cock

ADVANTAGES / STRENGTHS

- Differential pressure regulator function;
- Linear control valve function;
- Flow rate limiter function;
- Compact body for installation in boxes or tight spaces.

PRODUCT RANGE



3162

Multifunction kit for air terminal units (such as fan convectors, fan coils etc)

i Accessories 6542ATT - 6542SERV
For codes see page 120

Code	Type	Price €	Unit/Box
311 0001	1/2"		1/1
311 0002	3/4"		1/1

OPERATION/CONFIGURATIONS

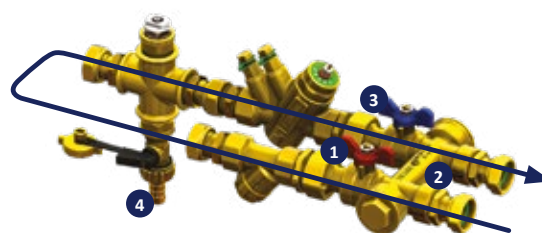

Normal operation:

- Configuration:
- Ball valves (1) - (3) open
 - Bypass (2) closed
 - Drain cock (4) closed

With this configuration, the water flows normally within the terminal unit.

The purpose of the kit is to regulate and maintain a constant flow rate as the differential pressure conditions of the system vary.



System flushing/servicing:

- Configuration:
- Ball valves (1) - (3) closed
 - Bypass (2) open

This configuration completely isolates the system, allowing system flushing and preventing impurities from circulating within the terminal unit/balancing valve.

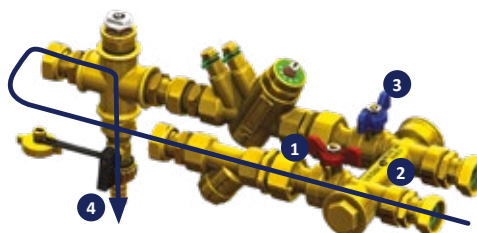

Terminal unit flushing:

- Configuration:
- Ball valve (1) open
 - Bypass (2) closed
 - Ball valve (3) closed
 - Drain cock (4) open

This configuration makes it possible to flush the system, including the terminal element, preventing impurities from circulating within the balancing valve.

06 COMPONENTS FOR PLUMBING SYSTEMS

06A Filters

Why filtration is so relevant 124

Self-cleaning filters  125

Strainers  128

06B Pressure reducing valves

 129

06C Thermostatic mixing valves

 133

06D Multifunction thermostatic regulator

 135

06E Anti-scald thermostatic kit with recirculation

 136

06F DHW temperature management and disinfection anti-legionella thermal device

 137

06G Water hammer arrestor

 140

Regardless of its origin, the water contains foreign bodies such as sand grains and other solid impurities, which inside hydraulic systems may cause different problems, in particular:

- **Corrosion phenomena caused by the deposition of impurities on the walls of the pipes (corrosion by differential aeration)**
- **Erratic operation of the adjustment and balance components**
- **Blockage and seizure of circulation pumps**
- **Occlusion of the heat exchangers**
- **Hindrance to heat from being transmitted evenly by the terminal elements**

The result is an increase in the cost of running and maintenance of the plant.

To avoid such problems, a filter must be installed at the water inlet point, in accordance with the regulations in force.

The Presidential Decree 59/09, the Ministerial Decree 37/08 and the technical standards UNI 9182 and UNI CTI 8065 provide for the safety filtration of water intended for human consumption and of water to be replenishing to technological circuits.

Tiemme filters are suitable for the purpose and meet the requirements of the regulations in force, and comply with the technical requirements prescribed by the Ministerial Decree On Health 25/2012. Construction materials in contact with water meet the requirements of the MD 174/04.

INSTALLATION

Tiemme self-cleaning filters and strainers are used for the protection of potable hydraulic circuits (domestic hot and cold water), for the replenishment and supply of wall boilers and for the supply of small cooling systems.

They find their application in pipes of cold water coming from the aqueduct (between the meter and the pressure reducing valve), and generally upstream of the hydraulic circuit to be protected, so as to preserve the entire section of the system placed downstream of the filter.

In order to facilitate maintenance, it is a good practice to intercept the filter by means of two ball valves located upstream and downstream of the filter. It is also recommended to provide a by-pass line, so as not to interrupt the water supply even during maintenance operations.

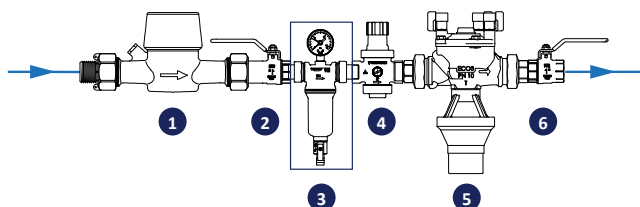

1. DCW meter
2. Shut-off valve
3. Self-cleaning filter with pressure gauge
4. Pressure reducing valve
5. Controllable low pressure backflow preventer
6. Shut-off valve

TIEMME INFORMS

The AISI 304 stainless steel filter mesh is the most important part of the filter, washable and possibly replaceable.

The degree of filtration depends on the number of mesh per cm² and is key when choosing the correct filter. The narrower the filter links, the greater the filtration capacity.

Each filter cartridge is characterized by a number expressed in microns, indicating its filtering capacity (**1 μm = 0,001 mm**). This value shows the minimum diameter of the blocked particle, giving an indication of the filtering power of the filter itself. The higher the micron value, the wider the filter mesh, the less mesh per cm², the lower the filter capacity.

The choice of the most suitable degree of filtration to be adopted is up to the user, depending on the type of application and the degree of impurities present in the fluid to be treated.

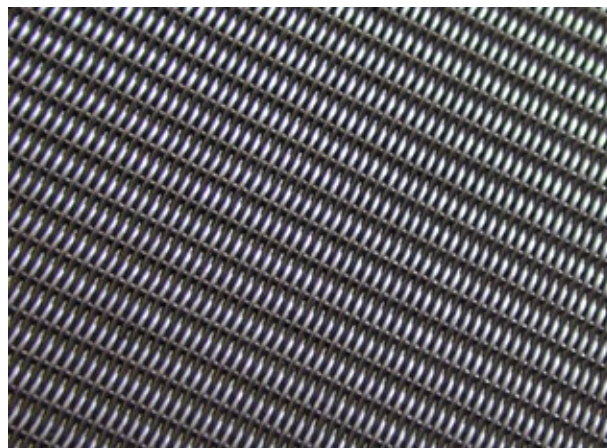

06_A SELF-CLEANING FILTERS

Once the water has been introduced into the self-cleaning filter, it flows through the filter element, releasing particles with a diameter greater than 100 µm on the outer surface of the element.

The filtered water is then sent out to the filter.

The cylinder head, made of brass, is complete with union connections that facilitate installation.

A cup is screwed on the head and is made of high-strength foodgrade plastic material or metal (depending on the version), in which the stainless steel filter element is housed.

The pressure gauge provided with the filter allows you to check the clogging of the cartridge. A drop in the pressure reading on the pressure gauge indicates the need for cleaning.

A drain and a drain cock are located at the bottom of the filter.

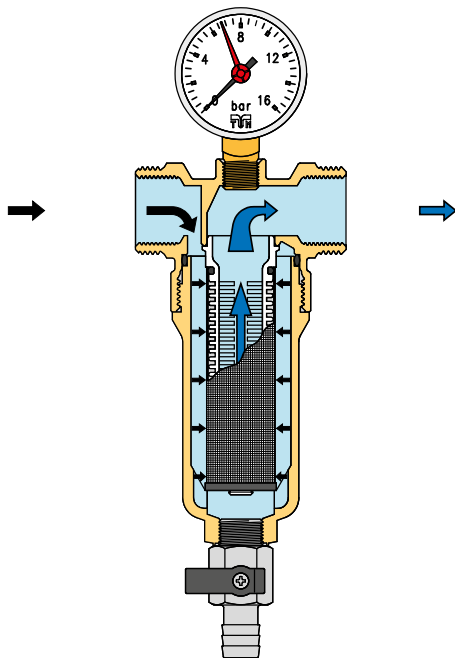

MAINTENANCE

The filter can be cleaned when the system is running, just by opening the drain.

Opening the drain will allow water from the system and some of the accumulated impurities to flow through the bottom of the filter.

To restore the filtration capacity of the device and proceed with a more thorough cleaning, it is sufficient to identify the ball valves located upstream and downstream of the filter, unscrew the cartridge-holder body and wash the filter mesh and the inner walls of the container.

Washing must be done only with water, using no chemicals.

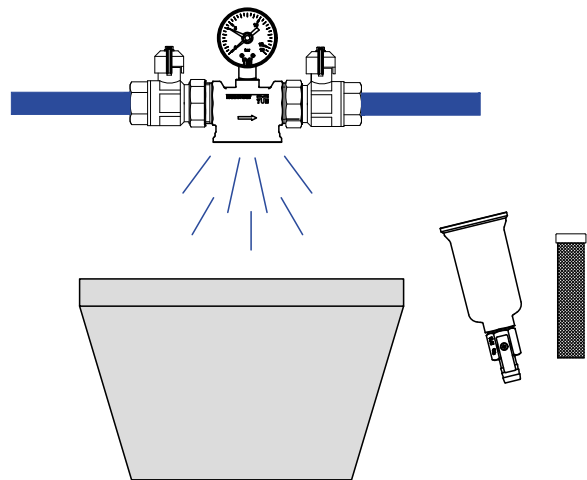

ASSEMBLY OPTIONS

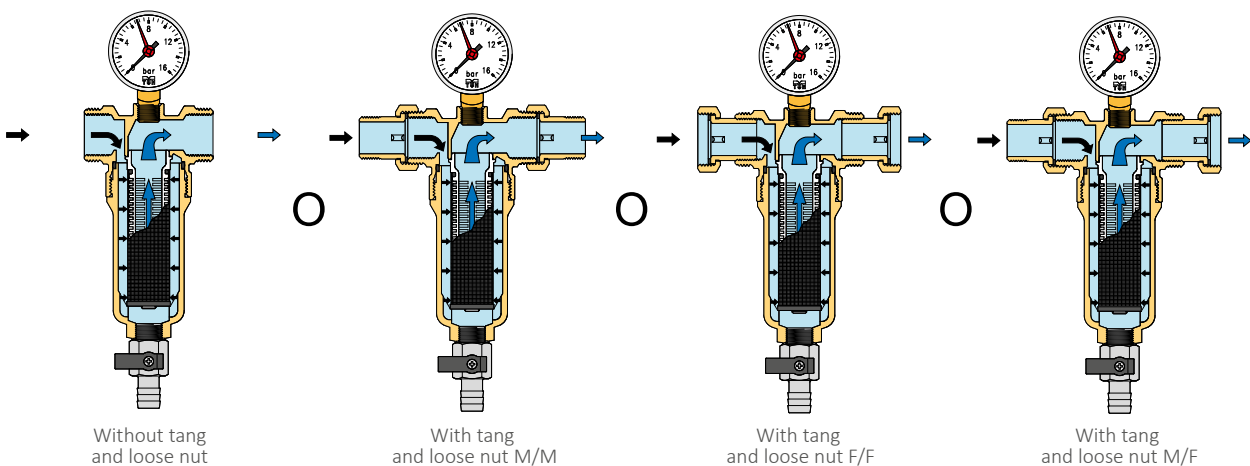

Without tang and loose nut

With tang and loose nut M/M

With tang and loose nut F/F

With tang and loose nut M/F



3135N
Self-cleaning filter with M/M
union connections

TECHNICAL SPECIFICATIONS

- Degree of filtration: 100 µm
- Collection cup material: transparent polycarbonate
- Body material: Brass CW617N nickel-plated
- Max operating pressure: 16 bar
- Max operating temperature: 65°C
- Connection threads: ISO 228 male
- Supplied with pressure gauge and drain cock

Code	Type	Price €	Unit/Box
313 0002	1/2"		1/14
313 0006	3/4"		1/14
313 0005	1"		1/14
313 0011	1"1/4		1/14



3130N
Self-cleaning filter with M/M
union connections

TECHNICAL SPECIFICATIONS

- Degree of filtration: 100 µm
- Collection cup material: Brass CW617N
- Body material: Brass CW617N nickel-plated or yellow
- Max operating pressure: 25 bar
- Max operating temperature: 95°C
- Connection threads: ISO 228 male
- Supplied with pressure gauge and drain cock

 Also available in yellow version

Code	Type	Price €	Unit/Box
313 0001	1/2"		1/14
313 0003	3/4"		1/14
313 0004	1"		1/14
313 0009	1"1/4		1/14



3136N
Self-cleaning filter with F/M
connections

TECHNICAL SPECIFICATIONS

- Degree of filtration: 100 µm
- Collection cup material: transparent polycarbonate
- Body material: Brass CW617N nickel-plated
- Max operating pressure: 16 bar
- Max operating temperature: 65°C
- Connection threads: ISO 228 male-female
- Supplied with pressure gauge and drain cock

Code	Type		Price €	Unit/Box
	F	M		
313 0017	1/2"	3/4"		1/14
313 0012	3/4"	1"		1/14
313 0015	1"	1"1/4		1/14
313 0020	1"1/4	1"1/2		1/14



3131N
Self-cleaning filter with F/M
connections

TECHNICAL SPECIFICATIONS

- Degree of filtration: 100 µm
- Collection cup material: Brass CW617N
- Body material: Brass CW617N nickel-plated or yellow
- Max operating pressure: 25 bar
- Max operating temperature: 95°C
- Connection threads: ISO228 female-male
- Supplied with pressure gauge and drain cock

 Also available in yellow version

Code	Type		Price €	Unit/Box
	F	M		
313 0007	1/2"	3/4"		1/14
313 0008	3/4"	1"		1/14
313 0010	1"	1"1/4		1/14
313 0014	1"1/4	1"1/2		1/14





3120N

Self-cleaning filter with F/F connections

TECHNICAL SPECIFICATIONS

- Degree of filtration: 100 µm
- Collection cup material: Brass CW617N
- Body material: Brass CW617N nickel-plated
- Max operating pressure: 16 bar
- Max operating temperature: 95°C
- Connection threads: ISO 228 female-female
- Supplied with 2 pressure gauges and drain cock

Code	Type	Price €	Unit/Box
313 0018	1" 1/2		1/6
313 0016	2"		1/8

ACCESSORIES AND SPARE PARTS



3145

Unions kit for self-cleaning filters 3131-3136

Code	Type	Price €	Unit/Box
313 0024	1/2" - 3/4"		1/50
313 0021	3/4" - 1"		1/40
313 0023	1" - 1" 1/4		1/30
313 0025	1" 1/4 - 1" 1/2		1/20



3140

Spare cartridge for self-cleaning filters

Code	Type	Price €	Unit/Box
313 0013	1/2" - 3/4"		1/50
313 0019	1" - 1" 1/4		1/50

The shape of the strainers allows the deposit of impurities on the bottom of the cartridge holder seat and simple and fast maintenance thanks to the possibility of unscrewing the closure cap and extracting the filter mesh.

The Tiemme strainer is characterized by its **compact size**.

It can be used as an alternative to self-cleaning filters where a frequent cleaning of the filter mesh is not required.

For a better filtration, we recommend to install the trainer on horizontal pipes with the cap facing downwards, in any case always refer to the direction of the fluid indicated by the arrow printed on the filter body.

In order to facilitate maintenance, it is a good practice to intercept the filter by means of two ball valves located upstream and downstream of the filter.

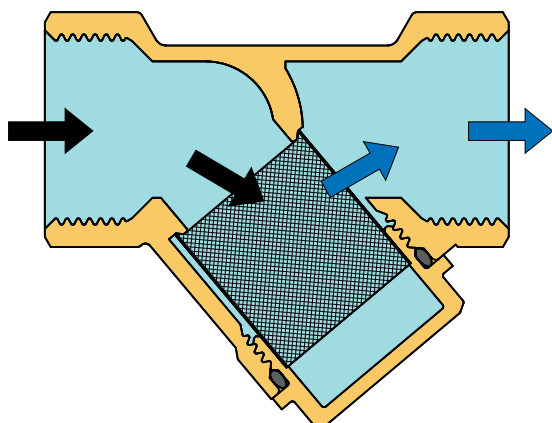

PRODUCT RANGE



3670
Y strainer

TECHNICAL SPECIFICATIONS:

- Degree of filtration: from 350 µm to 600 µm depending on diameter
- Body material: Brass CW617N
- Max operating pressure: 20 bar up to 2"; 16 bar over 2"
- Max operating temperature: 100°C
- Connection threads: ISO 228 female-female

Code	Type	Price €	Unit/Box
367 0003	1/2"		20/80
367 0001	3/4"		18/54
367 0002	1"		10/30
367 0005	1"1/4		4/16
367 0009	1"1/2		3/12
367 0004	2"		2/8
367 0011	2"1/2		1/8
367 0014	3"		1/5
367 0015	4"		1/1

Plug with hole for plumbing



3670CZISO7
Y strainer

TECHNICAL SPECIFICATIONS:

- Degree of filtration: from 350 µm to 500 µm depending on diameter
- Body material: Brass CW602N
- Max operating pressure: 20 bar
- Max operating temperature: 100°C
- Connection threads: ISO 7 female-female

DEZINCIFICATION RESISTANT

Code	Type	Price €	Unit/Box
367 0012	1/2"		25/75
367 0006	3/4"		15/45
367 0008	1"		8/24
367 0013	1"1/4		4/16
367 0010	1"1/2		3/12
367 0007	2"		2/8



Pressure reducing valves are mainly used in the domestic water circuits, in order to reduce and maintain the pressure of the water coming from the public water distribution system at a constant value.

This prevents pressure variations that could potentially damage components or lead to improper water distribution.

The compensated seat ensures that the set calibration value is maintained as the upstream pressure changes.

The Tiemme pressure reducing valves meet the parameters of EN 1567 standard, as part of the acoustic group II.

WHAT IS A COMPENSATED SEAT

The compensated seat, a manufacturing specification that characterizes the Tiemme pressure reducing valves, allows to avoid that changes in the upstream pressure interfere with the constant maintenance of the downstream set pressure.

This is possible because the upward thrust (closing of the reducing valve) and the downward thrust (opening of the reducing valve) generated inside the reducing valve are exerted on two equal surfaces, and equating: **equal and opposite forces cancel out.**

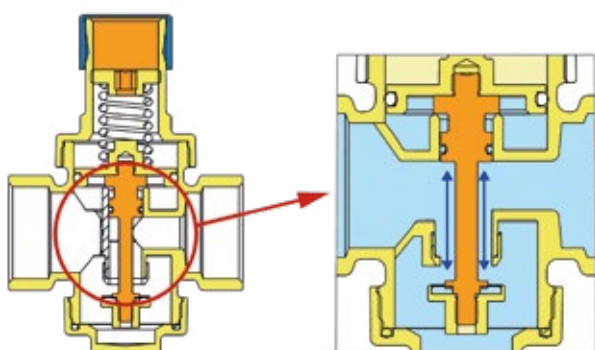

INSTALLATION

- Install a strainer or self-cleaning filter upstream of the pressure reducing valve in order to remove all impurities in the water that may deposit on the valve housing, causing abnormal operation.
- To facilitate possible maintenance operations, it is recommended to install shut-off valves upstream and downstream of the reducing valve.
- The water flow direction indicated on the body of the reducing valve (arrow) must be respected.
- The pressure reducing valve can be installed in a horizontal and vertical position equally.
- The system must be designed and constructed in such a way as to avoid stresses such as to damage the pressure reducing valve and prevent it from being correctly sealed and operating correctly. It is recommended that an anti-hammer device is inserted in the system in order to avoid yielding in the internal components of the reducing valve due to violent pressure returns.

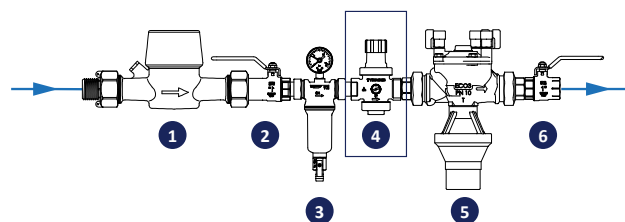

1. DCW meter
2. Shut-off valve
3. Self-cleaning filter with pressure gauge
4. Pressure reducing valve
5. Controllable low pressure backflow preventer
6. Shut-off valve

SETTING THE PRESSURE VALUE

Before being packaged all pressure reducing valves are tested and calibrated at the outlet pressure of 3 bar.

The outlet pressure can be easily changed once the pressure reducing valve is installed on the system.

To change the outlet pressure, simply press the spring-press.



- Turning clockwise increases the outlet pressure, turning counterclockwise decreases the outlet pressure.
- The calibration operation is completed when the pressure gauge indicates the desired pressure.
- Correct pressure adjustment must be performed with a full hydraulic circuit and all utilities closed.

USEFUL TIPS - DETERMINING THE CORRECT PRESSURE REDUCTION RATIO

The correct set pressure value must be determined in such a way as to avoid dangerous cavitation phenomena. Cavitation could in fact cause malfunctions, damage the valve itself and annoying noise phenomena. The general rule is that the ideal ratio between the upstream pressure (to be reduced) and the downstream pressure (desired in the circuit) is set to the value 2:1. At most this ratio can reach 3:1

CAVITATION DIAGRAM

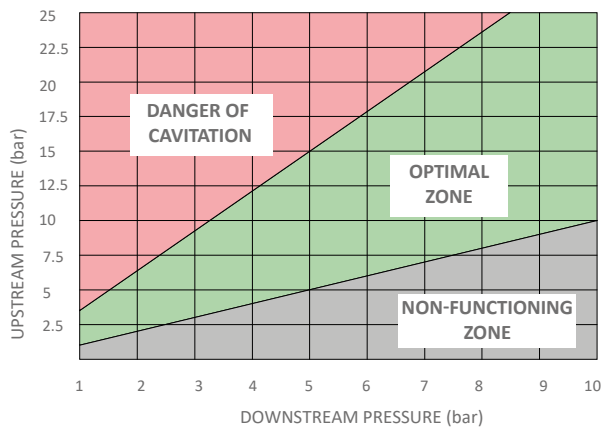

When the ratio between the upstream pressure and the downstream pressure exceeds 3:1, the component is operated in cavitation, it is therefore necessary to provide two pressure reducing valves installed one after the other. This is to perform A FIRST LEVEL REDUCTION and then A SECOND LEVEL REDUCTION.

EXAMPLE:

I have to reduce the pressure from 15 bar to 3 bar. The ratio $15:3 = 5$ which exceeds the limit ratio of 3:1. Two pressure reducing valves must be provided in series. With the first valve the pressure will be lowered from 15 bar to 6 bar, with the ideal ratio $15:6 = 2.5$ (FIRST LEVEL REDUCTION).

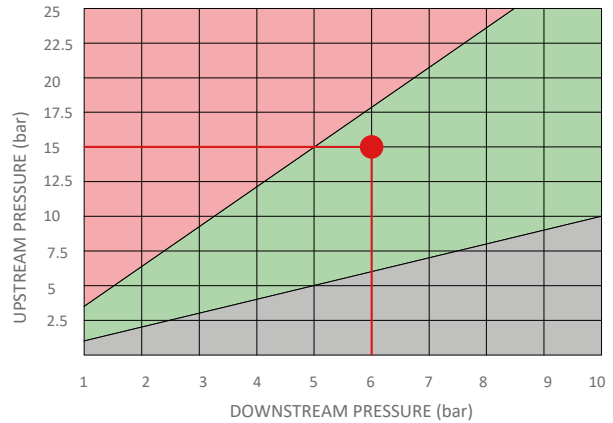

With the second valve the pressure will be lowered from 6 bar to 3 bar, with the ideal ratio $6:3 = 2$ (SECOND LEVEL REDUCTION).

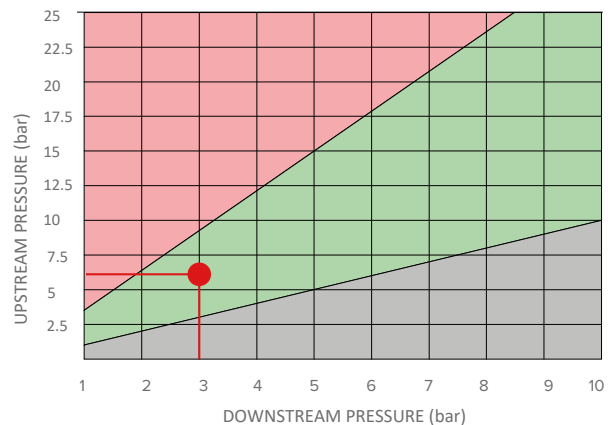



3100N
Pressure reducing valve, with piston, F-F connections

TECHNICAL SPECIFICATIONS

- Adjustment range: 1-4 bar (Factory setting 3 bar)
- Max inlet pressure: 15 bar
- Max operating temperature: 80°C
- Body material: Brass CW617N nickel-plated
- Connection threads: ISO 228 female
- Pressure gauge connection: 1/4"

Code	Type	Price €	Unit/Box
318 0021	3/8"		1/50
318 0057	1/2"		1/25
318 0058	3/4"		1/25

Until out of stock



3110N
Pressure reducing valve, with piston, F-F connections

TECHNICAL SPECIFICATIONS

- Adjustment range: 1-6 bar (Factory setting 3 bar)
- Max inlet pressure: 25 bar
- Max operating temperature: 80°C
- Body material: Brass CW617N nickel-plated
- Connection threads: ISO 228 female
- Pressure gauge connection: 1/4"

Code	Type	Price €	Unit/Box
318 0008	1/2"		1/10
318 0010	3/4"		1/10
318 0003	1"		1/8
318 0012	1"1/4		1/8
318 0014	1"1/2		1/8
318 0009	2"		1/8
318 0016	2"1/2		1/2
318 0015	3"		1/1
318 0006	4"		1/1



3108N
Pressure reducing valve with piston, M-M unions

TECHNICAL SPECIFICATIONS

- Adjustment range: 1-6 bar (Factory setting 3 bar)
- Max inlet pressure: 25 bar
- Max operating temperature: 80°C
- Body material: Brass CW617N nickel-plated
- Connection threads: ISO 228 male
- Pressure gauge connection: 1/4"

Code	Type	Price €	Unit/Box
318 0068	1/2"		1/10
318 0069	3/4"		1/10
318 0070	1"		1/8
318 0071	1"1/4		1/8
318 0072	1"1/2		1/4
318 0075	2"		1/4



3107N
Pressure reducing valve, with piston, F-F unions

TECHNICAL SPECIFICATIONS

- Adjustment range: 1-6 bar (Factory setting 3 bar)
- Max inlet pressure: 25 bar
- Max operating temperature: 80°C
- Body material: Brass CW617N nickel-plated
- Connection threads: ISO 228 female
- Pressure gauge connection: 1/4"

Code	Type	Price €	Unit/Box
318 0002	1/2"		1/10
318 0004	3/4"		1/10
318 0011	1"		1/8
318 0019	1"1/4		1/8
318 0020	1"1/2		1/4
318 0018	2"		1/4



3180
Pressure reducing valve, with diaphragm, F-F unions

TECHNICAL SPECIFICATIONS

- Adjustment range: 1-6 bar (Factory setting 3 bar)
- Max inlet pressure: 16 bar
- Max operating temperature: 65°C
- Body material: Brass CW617N nickel-plated
- Connection threads: ISO 7/EN 10226 female
- Pressure gauge connection: 1/4"

i For spare cartridge see 3180C

Code	Type	Price €	Unit/Box
318 0017	1/2"		1/10
318 0013	3/4"		1/10



3111
Bronze piston pressure reducing valve with flanged connections

TECHNICAL SPECIFICATIONS

- Adjustment range: 1.5-7 bar (factory setting 3 bar)
- Max inlet pressure: 30 bar
- Max operating temperature: 80°C
- Body material: Bronze
- Unions: Flange UNI EN 1092-3
- Pressure gauge connection: 1/4"

Code	Type	Price €	Unit/Box
318 0082	DN 50		1/1
318 0083	DN 65		1/1
318 0084	DN 80		1/1
318 0085	DN 100		1/1

ACCESSORIES AND SPARE PARTS



2080
Manometer radial connection
Ø50

Code	Type	Scale	Price €	Unit/Box
318 0007	1/4"	0 - 6 bar		5/25
318 0025	1/4"	0 - 16 bar		5/25



2080POST
Manometer with back connection



Code	Type	Scale	Price €	Unit/Box
192 0017	1/4"	0 - 10 bar		1/40



3180C
Spare cartridge for pressure reducing valve 3180 and filling unit 3160K-3161

Code	Type	Price €	Unit/Box
318 0053	3180/ 3160K/3161		1/40



The thermostatic mixing valve for domestic installations **allows the instantaneous mixing of the inlet fluids, thus ensuring stability on the set value of the temperature of the outlet fluid**, both when the flow rate taken by the different users varies, and when the pressure and temperature conditions of the primary fluids may vary.

The mixing function is performed by the thermostatic wax element, which in contact with the water undergoes a variation in the volume, which determines the correct supply of hot and cold water at the inlet and consequently the regulation of the temperature of the water at the outlet set value.

SCOPE

It finds application to adjust and control the distribution temperature of the domestic system coming from the heat/accumulation generator.

In case of interruption of the cold water flow the water completely stops within 5 seconds and prior to the coming of 200 ml of water, according to UNI EN 1111 regulations.

OPERATION

The regulator element of the thermostatic mixing valve is a temperature sensor completely immersed in the outlet duct of the mixed water which, with its dilation or contraction, continuously establishes the right proportion between hot water and cold water at the inlet. These flows are regulated by means of a piston which slides in a suitable cylinder between the junction of hot and cold water. Even when pressure drops due to hot or cold water being drawn from other consumers or temperature variations at the inlet, the mixer automatically adjusts the water flow rates until the set temperature is reached.

INSTALLATION

- Remove any dirt that may be present due to the construction of the system.
- In the case of very hard or aggressive water, it is recommended to treat the water before entering the thermostatic mixing valve.
- The thermostatic mixing valve can be installed in all positions equally.
- Provide ball shut-off valves upstream and downstream of the thermostatic mixing valve.
- Avoid differences between hot and cold primary fluid supply pressures. The insertion of devices with considerable pressure drops (e.g. filters) must not take place on one of the supply branches of the thermostatic mixer, but on the common mains portion.
- Provide appropriate filters upstream of the system.
- Respect the correct installation direction of the mixer connections, as follows:

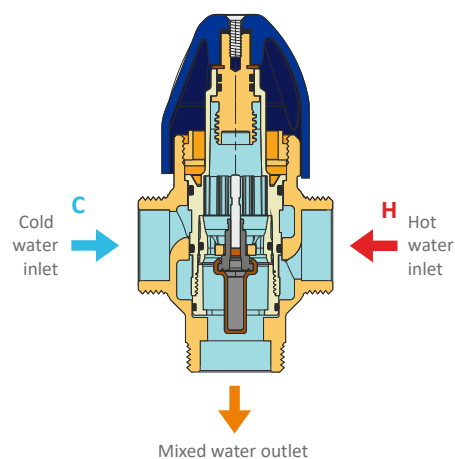
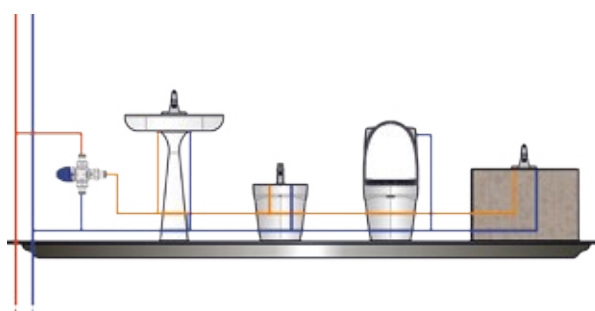

Diagram 1: Example of single-use bathroom installation





4737
Chrome-plated female thermostatic adjustable mixing valve for DHW

TECHNICAL SPECIFICATIONS

- Compliance with: UNI EN 1111
- Temperature range: 30÷55°C
- Max operating pressure: 10 bar
- Max inlet temperature: 90°C
- Body material: Brass CW617N
- Handle material: PA
- Flow rate at 3 bar: 30 l/min

Code	Type	Price €	Unit/Box
320 0038	1/2"		1/10
320 0037	3/4"		1/10



4739
Chrome-plated male thermostatic adjustable mixing valve for DHW

TECHNICAL SPECIFICATIONS

- Compliance with: UNI EN 1111
- Temperature range: 30÷55°C
- Max operating pressure: 10 bar
- Max inlet temperature: 90°C
- Body material: Brass CW617N
- Handle material: PA
- Flow rate at 3 bar: 30 l/min

Code	Type	Price €	Unit/Box
320 0039	1/2"		1/10
320 0040	1/2" with non-return valve		1/10



4738
Chrome-plated M thermostatic adjustable mixing valve for DHW

TECHNICAL SPECIFICATIONS

- Compliance with: UNI EN 1111
- Temperature range: 30÷55°C
- Max operating pressure: 10 bar
- Max inlet temperature: 90°C
- Body material: Brass CW617N
- Handle material: PA
- Flow rate at 3 bar: 30 l/min (3/4") - 72 l/min (1")

Code	Type	Price €	Unit/Box
320 0036	3/4"		1/10
320 0001	1"		1/10



4738KIT
Fittings kit for thermostatic mixing valve 4738

i The kit includes: 3 tails, 3 nuts and 3 gaskets

Code	Type	Price €	Unit/Box
For 4738 (3/4")			
470 0454	3/4" x 1/2"		1/10
470 0455	3/4" x 1/2" with non-return valve		1/10
470 0475	3/4" x 3/4"		1/10
470 0474	3/4" x 3/4" with non-return valve		1/10
For 4738 (1")			
470 0190	1" x 3/4"		1/10
470 0191	1" x 3/4" with non-return valve		1/10
470 0192	copper union Ø22 compression		1/10



4738G
Thermostatic mixing valve for domestic systems - high flow rates

TECHNICAL SPECIFICATIONS

- Temperature range: 30÷65°C
- Max operating pressure: 10 bar
- Max inlet temperature: 90°C
- Body material: Brass CW625N
- Handle material: PA
- Minimum flow rate for correct operation:
12 l/min. (1"1/4) - 15 l/min. (1"1/2) - 25 l/min. (2") - 30 l/min. (2"1/2)

+ DEZINCIFICATION RESISTANT

Code	Type	Price €	Unit/Box
320 0046	1" 1/4		1/8
320 0047	1" 1/2		1/8
320 0049	2"		1/8
320 0051	2" 1/2		1/8



1521CPKIT
Union kit

i The kit includes: 3 tails, 3 nuts and 3 gaskets

Code	Type	Price €	Unit/Box
150 1013	1"1/4 F x 1" M		1/15
150 1014	1"1/2 F x 1"1/4 M		1/10
150 1015	2" F x 1"1/2 M		1/10
150 1016	2"1/2 F x 2" M		1/5



06_D MULTIFUNCTION THERMOSTATIC REGULATOR

The multifunction thermostatic regulator is used to automatically balance the recirculation circuits of DHW distribution systems, so as to ensure that all sections of the mains reach the set temperature value.

It is also equipped with a by-pass device, which automatically comes in in case of thermal disinfection against Legionella.

The thermostatic regulator is available in two options, depending on the mode of operation of the anti-Legionella disinfection function:

- Completely automatic, by means of a special thermostatic cartridge which takes action at about 70°C (art. 4733)
- controlled, by means of an electrothermal actuator, managed by a special control unit (art. 4734)

PRODUCT RANGE



4733
Multifunction thermostatic regulator for DHW recirculation circuits

+ DEZINCIFICATION RESISTANT

Code	Type	Price €	Unit/Box
473 0005	1/2"		1/10
473 0006	3/4"		1/6



4734
Multifunction thermostatic regulator for DHW recirculation circuits with thermal disinfection controlled by actuator

+ DEZINCIFICATION RESISTANT

Code	Type	Price €	Unit/Box
473 0007	1/2"		1/8
473 0008	3/4"		1/8

OPERATION

TEMPERATURE CONTROL:

In DHW distribution circuits, in compliance with modern plant arrangements for the control of Legionella, it is necessary to ensure that all sections are kept at the correct temperature. The recirculation network must be balanced to avoid uneven temperature distributions.

The thermostatic regulator, inserted in each branch of the recirculation circuit, maintains the set temperature automatically.

By the action of a specific internal thermostatic cartridge (Fig. 1), it modulates the flow of fluid according to the temperature of the inlet water.

As the coolant temperature approaches the set value, the shutter gradually reduces the flow.

In this way the fluid pushed by the recirculation pump is distributed on the other parts of the network, realizing an effective automatic thermal balance.

THERMAL DISINFECTION:

The multifunction thermostatic regulator is also equipped with the anti-Legionella thermal disinfection function.

This function is performed by a by-pass device (Fig. 2) which automatically intervenes when a temperature of about 70°C is reached (in the case of product art. 4733) or controlled by means of an electrothermal actuator, managed by a suitable control unit (in the case of the product art. 4734).

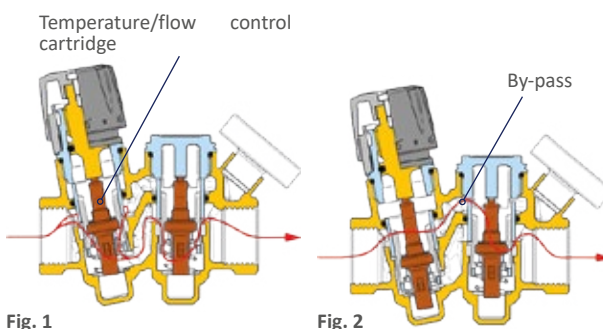
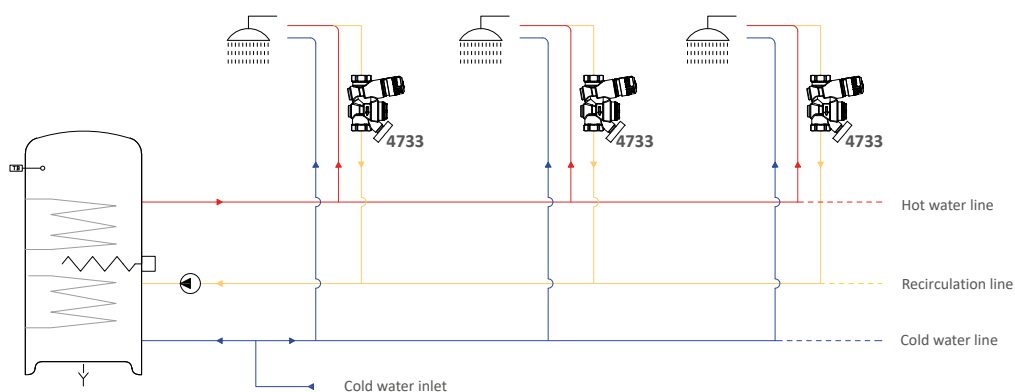

Fig. 1

Fig. 2

When conditions are reached, the bypass opens the circuit, regardless of the action of the temperature/flow rate regulating cartridge.

INSTALLATION EXAMPLE



06_E ANTI-SCALD THERMOSTATIC KIT WITH RECIRCULATION

The anti-scald thermostatic kit with recirculation art. 4738KR provides an easy connection between the DHW distribution system, the accumulation storage and the recirculation system.

Complete with 3 shut-off valves and 3 check valves, it allows simple management of the DHW delivery temperature making it instantly available to the dispensing taps of the different users.

OPERATION

The Tiemme thermostatic kit art. 4738KR is ideal, where the immediate availability of DHW to the users is desired, in cases where the production of DHW takes place at a distance greater than 15m from the dispensing taps. As can be seen from the hydraulic diagram, the hot water, coming from the DHW storage, is connected at the inlet to the thermostatic mixer which allows the water to be regulated to the users from 30°C to 55°C. The recirculation circuit connected to the mixed line outlet near the consumers (domestic manifold) must be connected to the pump inlet. In case of hot water request from the users, the circulation pump sends the recirculation water to the cold water inlet of the mixing valve or to the accumulation allowing the reuse of the mixed water. On the left side of the unit is the cold water connection from the network for filling the accumulation and mixing. It is possible to manage the pump operation by means of a timer to ensure the operation only during the times set by the user and therefore to get a greater energy saving.

With the Tiemme Climav 2.0 Building Management system it is possible to manage the recirculation system automatically.

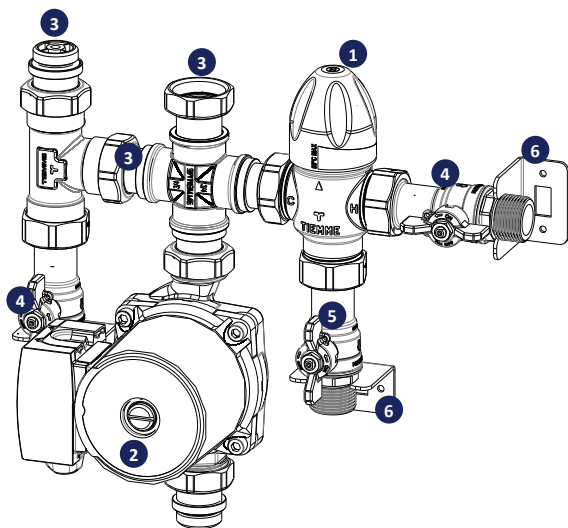

1. Thermostatic mixing valve;
2. Circulation pump;
3. Non-return valve;
4. Ball valve;
5. Ball valve with non-return;
6. Retaining bracket.

ADVANTAGES / STRENGTHS

- Easy connection to the DHW distribution system;
- Thermostatic mixer, adjustable from 30 to 55°C;
- Complete with check and shut-off valves;
- Pre-assembled unit easy to install.

INSTALLATION EXAMPLE

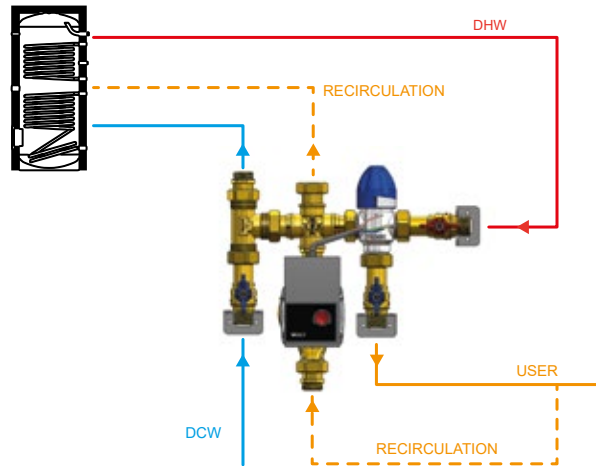

DIMENSIONS

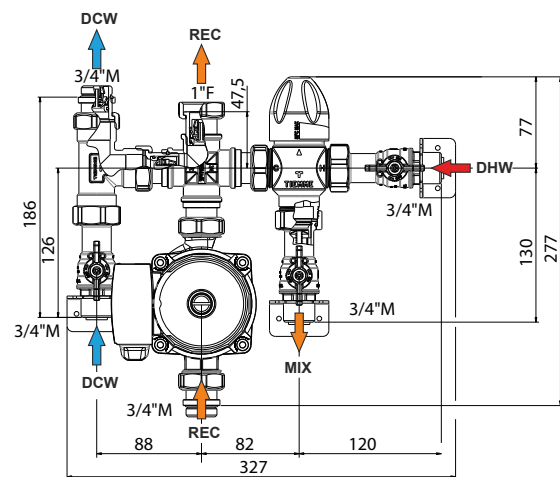

PRODUCT RANGE



4738KR
Anti-scald thermostatic kit with recirculation

TECHNICAL SPECIFICATIONS

- Mixer according to: UNI EN 1111
- Temperature range: 30÷55°C
- Max operating temperature: 90°C
- Max operating pressure: 10 bar

Code	Type	Price €	Unit/Box
320 0002	30÷55°C		1/1



WHAT IS LEGIONELLA?

Legionella is a bacterium naturally present in water (rivers, lakes, wells...). It can be found inside water mains and is able to survive the normal water potabilization treatments. Its presence is not in itself a dangerous factor, but can become dangerous if the conditions that favor its proliferation coexist creating a fertile soil for development to the bacterium:

- Presence of amoeba;
- Biofilm;
- Presence of encrustations and sediments;
- Stagnation condition.



BEHAVIOR OF THE BACTERIUM AS A FUNCTION OF WATER TEMPERATURE

Legionellosis can be contracted by breathing contaminated water diffused in aerosol, i.e. vaporized in very fine droplets. The bacteria survive at a water temperature of between 5,7°C and 55°C, while the maximum of their proliferation occurs at temperatures of between 25°C and 42°C.

It is therefore possible to understand that in centralized plants, where accumulation DHW is produced plus a recirculation system, the proliferation possibilities of the Legionella bacterium may become rather high.

In the diagram below we can understand the behavior of the Legionella bacterium as a function of the water temperature:

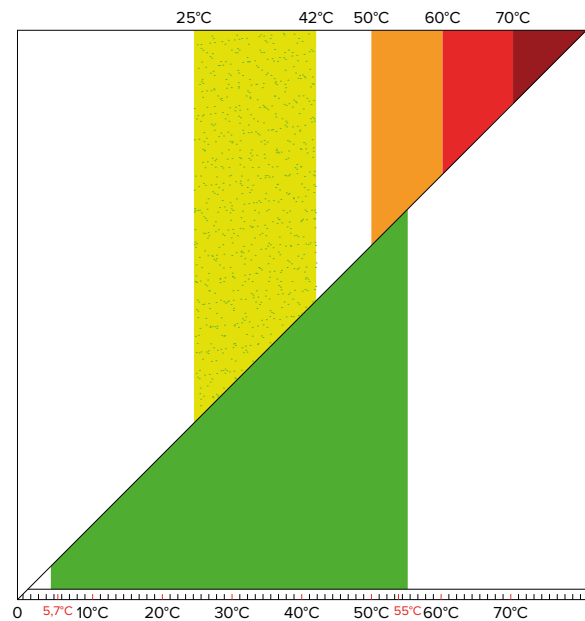

- BACTERIA SURVIVAL ZONE
- BACTERIA PROLIFERATION ZONE
- DEATH ZONE 90% BACTERIA IN VERY LONG PERIODS > 2 HOURS
- DEATH ZONE 90% BACTERIA IN VERY SHORT PERIODS > 2 MIN.
- DEATH ZONE 90% BACTERIA IN AN INSTANT

LEGIO-TIEMME is a device used for the management of the DHW temperature controlled by the control unit that acts on the servo-control mounted on board. In addition to the management of the outlet temperature for the user, the electronics periodically activate, depending on the programming carried out by the installer, the disinfection of the DHW and RECIRCULATION ducts to prevent the proliferation of the Legionella bacterium harmful to human health.

To complete the functions, LEGIO-TIEMME is equipped with a network for the activation of alarms, the signaling of anti-Legionella cycle in progress and the option to activate an additional generator for raising the temperature during the disinfection cycle.

ADVANTAGES / STRENGTHS

- Compact solution;
- Electronic control of user temperature;
- Management of disinfection of DHW line and recirculation;
- Easy and intuitive programming;
- Possibility to match it with the advanced system CLIMAV 2.0;
- App control;
- Temperature control of the boiler.

FEATURES

The LEGIO-TIEMME controller manages a thermal storage for DHW production and disinfection in order to optimize user comfort and energy saving.

KEY DEVICE FEATURES:

- Thermostatic adjustment of domestic hot water (DHW).
- Thermostataction accumulation.
- Recirculation: Useful for improving DHW use times and piping disinfection.
- Anti-Legionella cycle applied both to the accumulation and the pipes.
- Interfacing with Climav 2.0 Building Management system via BUS 485.

SOFTWARE FEATURES:

- Automatic disinfection cycle depending on the temperature of the heat generator.
- Possibility to activate generator temperature rise (OVER BOOST) system during the anti-legionella cycle.
- App control.
- Integrated algorithms for optimization of disinfection times.
- During the disinfection cycle, the recirculation pump will be started to completely sanitize the system.
- Store success or failure reports of each disinfection cycle.
- Automatic time start or manual immediate start of the anti-legionella cycle.
- Manual adjustment of the DHW set-point.

OPERATION

The electronics, by reading the probe positioned at the outlet on the mixed water line, controls the DHW temperature by balancing the inlet of hot and cold water so that the output value is equal to the value set during programming, usually between 45°C and 50°C. The next function is to activate the disinfection process, usually started at night.

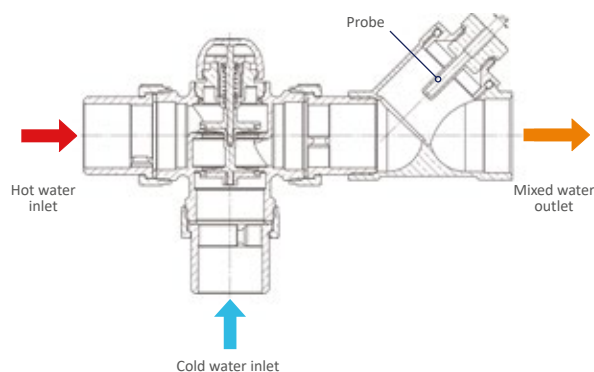

PRODUCT RANGE



4723KIT

LEGIO-TIEMME Mixer kit with connections, supplied with user-side probe holder

Code	Type	Price €	Unit/Box
320 0022	1"1/4		1/1
320 0023	1"1/2		1/1



9562P1

Proportional servo control with 0÷10V signal for 3-way mixing valve

Code	Type	Price €	Unit/Box
450 0652	0÷10V - 24 Vac		1/10



5530P

Temperature probe NTC 10KΩ @ 25°C, diameter 6 mm

Code	Type	Price €	Unit/Box
555 0149	-		1/10





4723CENTR
 LEGIO-TIEMME control unit
 for the management of the
 domestic installation and anti-
 Legionella treatment

TECHNICAL SPECIFICATIONS

- Power supply: 85-230 Vac
- Absorption: < 5 W
- Protection fuse: 1A
- Graphic display: 1,8" color
- Dimensions: 6 modules for DIN rail installation
- Interface: Keyboard 7 buttons
- Outputs:
 - 24 Vdc servomotor supply for mixing valve
 - Analog output for mixing valve control
 - Recirculation pump activation relay
 - Generator overboost request relay
 - Anti-Legionella cycle relay active
 - Alarm relay
- Digital inputs:
 - Recirculation pump thermal trip
 - Electrical resistance thermal trip
 - Flow switch
 - Recirculation consent
- Analog inputs
 - NTC probe reading T accumulation
 - NTC probe read T delivery
 - NTC probe read T return (recirculation)

Code	Type	Price €	Unit/Box
320 0024	-		1/1

INSTALLATION EXAMPLE

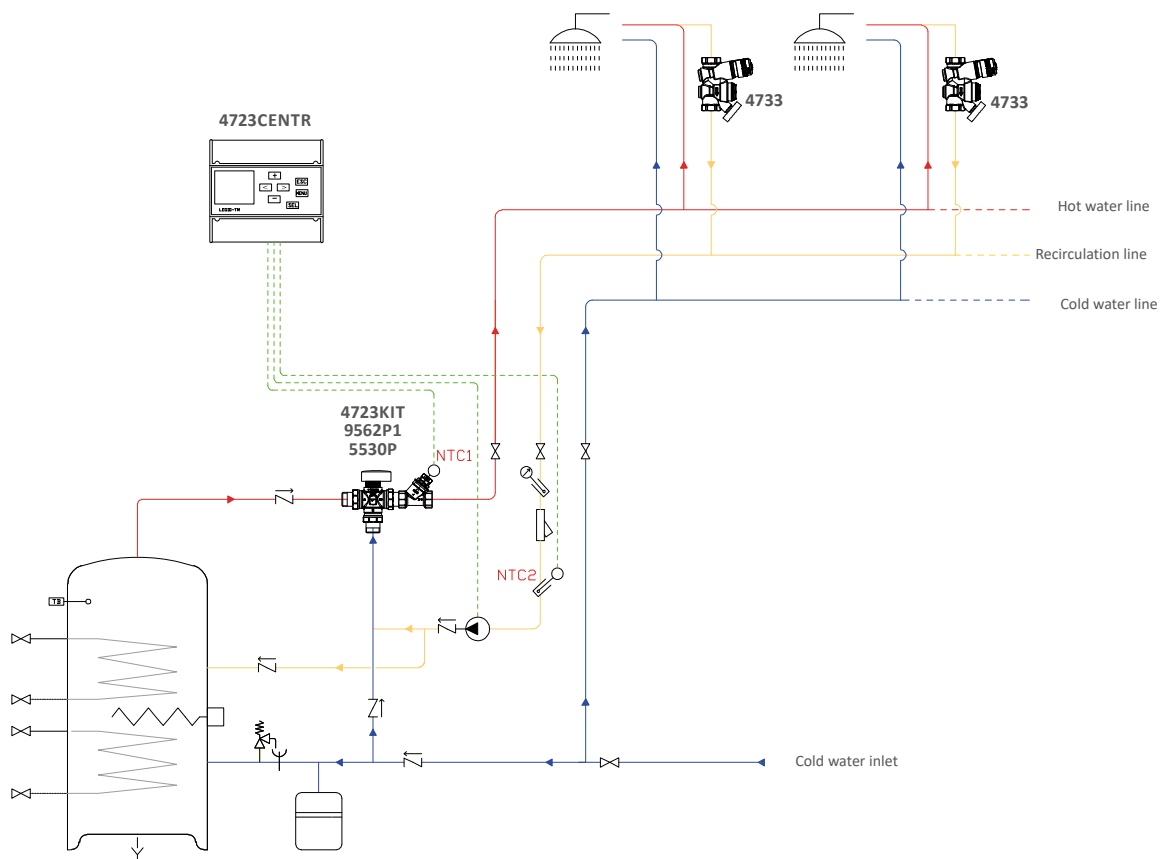

06G WATER HAMMER ARRESTOR

In water systems where ball valves, mixing valves, solenoid valves or other devices for rapid interception of the fluid are present, it is frequent to incur the phenomenon of "water hammer" caused by a sudden deceleration and/or acceleration of the fluid which generates overpressure and/or depressions. This can damage the relevant components and especially the pipes.

The Tiemme device art. 1935 is conceived to preserve the system from possible damage and must be installed as close as possible to the devices for rapid interception of the fluid, on the distribution manifold of the single circuits or at the main inlet of the circuit. The device can be installed in any position (horizontal, vertical, face-down).

In order to ensure the correct operation of the device and the proper functioning of the hydraulic components (cocks, manifolds, etc.) it is preferable to install a pressure reducing valve rated at 3÷4 bar at the main inlet of the water supply and to size the system in order not to have too high speeds inside the pipes. It is also appropriate that the installation of the device be carried out in compliance with the requirements of the "Guidelines for the prevention and control of Legionellosis" [if any] dictated by the Ministry of Health, avoiding its positioning in "dead zones" difficult to reach by disinfection.

The overpressure caused, for example, by the sudden closure of the shut-off elements are added to the pressures already present inside the plant, causing the following possible drawbacks:

- broken lines, tanks and hoses
- damage to shut-off, retaining and adjustment devices
- high noise and vibration in pipes and components.

An evaluation of the overpressure can be made by means of the following formula which relates the speed of the fluid in the pipe, the length of the pipe section and the closing time of the shut-off member:

$$\Delta p = \frac{2 \cdot v_1 \cdot L}{g \cdot t}$$

where:

Δp = overpressure due to water hammer (m wh)

v_1 = initial fluid speed (m/s)

L = length of pipe section (m)

g = acceleration of gravity (equal to 9,81 m/s)

t = closing time of the shut-off member (s)

OPERATION

The Tiemme water hammer arrestor consists of a cylinder equipped with a plate and contrast spring that divides it into two chambers. The chamber 2 is connected to the pipe and fills up with water. Any overpressures that may be generated in the system are damped by the contrast spring.

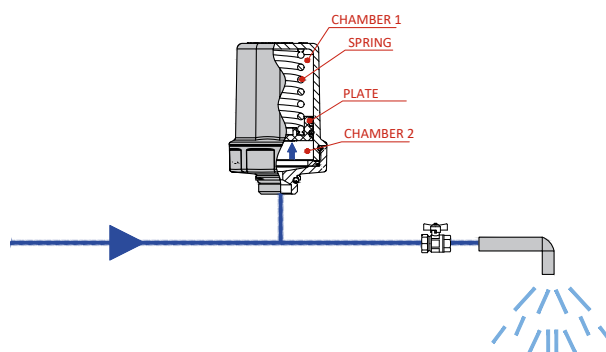

INSTALLATION EXAMPLE



PRODUCT RANGE



1935

Water hammer arrestor

TECHNICAL SPECIFICATIONS

- Body: Brass CW617N chrome plated
- Damper: POM
- Spring: steel
- Seals: EPDM
- Application fluid: wter
- Max operating pressure: 10 bar
- Max fluid temperature: 110°C
- Max wer hammer pressure: 50 bar
- Start of active intervention: 3 bar
- Unions: 1/2" M with EPDM seal

Code	Type	Price €	Unit/Box
194 0001	1/2"		1/25



07 ANTI-POLLUTION DEVICES

07A Anti-pollution devices - introduction 142

07B Check valves



143

07C Backflow preventers



145

SCOPE

Check valves and backflow preventers are devices designed to prevent pollution from the water supply due to the accidental return of contaminated fluid from the downstream system (USERS), due to pressure variations in the distribution network.

These devices, installed between the public network and the user network in the water distribution systems, avoid contact between the waters contained in the two separate networks, automatically closing if the backflow conditions occur.

The flow reversal direction phenomenon may occur due to two conditions:

1. The water supply pressure is lower than DOWNSTREAM mains pressure, for example due to the water mains failure (REVERSE SIPHONING).

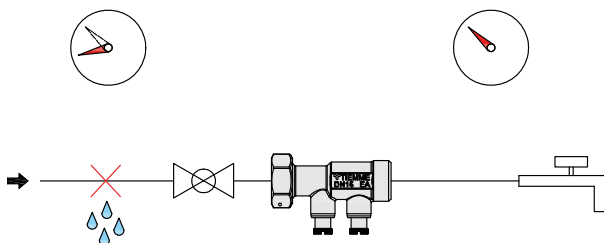

2. In THE DOWNSTREAM circuit the pressure rises, for example due to the pumping of water from a well

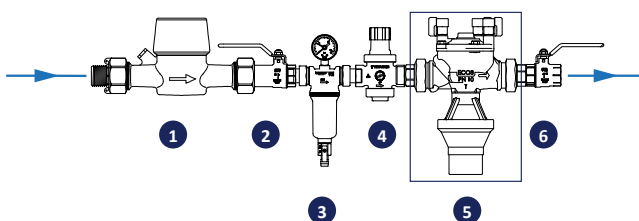
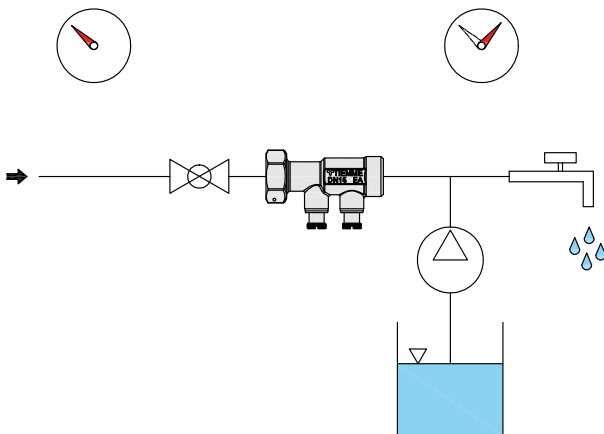

1. DCW meter
2. Shut-off valve
3. Self-cleaning filter with pressure gauge
4. Pressure reducing valve
5. Controllable low pressure backflow preventer
6. Shut-off valve

REGULATORY REFERENCE

The correct application of anti-pollution devices is regulated by European regulations on the prevention of backflow pollution.

The reference standard is EN 1717 "Protection against pollution of potable water in hydraulic systems and general requirements of devices designed to prevent backflow pollution".

In this standard, the water in the system is classified according to the degree of dangerousness to human health:

Category 1:	Water that can be used for human consumption provided by the distributor body
Category 2:	Fluid that does not represent a risk to health, as in 1, whose qualities have been compromised as a result of a change in temperature, taste, odor or appearance.
Category 3:	Fluid that presents a certain health risk due to the presence of harmful substances.
Category 4:	Fluid presenting a health risk due to the presence of one or more "toxic substances" or "very toxic" or one or more radioactive, mutagenic or carcinogenic substances.
Category 5:	Fluid that presents a serious health risk due to the presence of microbiological or viral elements.

According to this classification, an appropriate backflow preventer device must be inserted in the water distribution circuits..

- **The check valves can be used to protect the water mains against the risk of contamination from water up to category 2.**
- **The backflow preventers can be used to protect the water mains against the risk of contamination from water up to category 4.**



07_B CHECK VALVES

UNCONTROLLABLE



3500

Check valve YACHT female/
female ISO 228 with polyamide
shutter



Code	Type	Price €	Unit/Box
350 0003	1/2"		15/60
350 0004	3/4"		12/48
350 0001	1"		8/32
350 0006	1"1/4		6/24
350 0008	1"1/2		4/16
350 0007	2"		2/8
350 0022	2"1/2		1/6
350 0018	3"		1/4
350 0034	4"		1/2



3506

Check valve EUROSTOP female/
female ISO 228 with polyamide
shutter



Code	Type	Price €	Unit/Box
350 0142	1/2"		15/60
350 0143	3/4"		10/40
350 0144	1"		6/24
350 0145	1"1/4		5/20
350 0146	1"1/2		2/8
350 0147	2"		2/8
350 0050	2"1/2		1/6
350 0051	3"		1/4
350 0058	4"		1/2



3600

Check valve YACHT female ISO
228 with polyamide shutter and
stainless steel filter



Code	Type	Price €	Unit/Box
350 0053	1/2"		8/80
350 0037	3/4"		8/48
350 0012	1"		7/63
350 0027	1"1/4		6/24
350 0039	1"1/2		4/20
350 0040	2"		2/18
350 0057	2"1/2		1/6
350 0059	3"		1/3
350 0065	4"		1/2



3606

Check valve EUROSTOP female
ISO 228 with polyamide shutter
and stainless steel filter



Code	Type	Price €	Unit/Box
350 0348	1/2"		16/64
350 0349	3/4"		12/48
350 0350	1"		9/36
350 0351	1"1/4		4/16
350 0352	1"1/2		3/12
350 0353	2"		2/8
350 0354	2"1/2		1/5
350 0355	3"		1/3
350 0356	4"		1/2

07_B CHECK VALVES

ACCESSORIES



3510
Stainless steel filter for check valve

Code	Type	Price €	Unit/Box
350 0054	1/2"		1/100
350 0044	3/4"		1/50
350 0029	1"		1/25
350 0038	1"1/4		1/20
350 0056	1"1/2		1/10
350 0052	2"		1/5
350 0064	2"1/2		1/4
350 0063	3"		1/3
350 0046	4"		1/2

CHECK VALVES

CONTROLLABLE (EA TYPE)

The controllable check valves (EA type) art. 3681 are characterized by two sockets on the body with specific and precise functions:

- The first socket, along the flow direction, allows to inspection of the correct operation of the check device (VNR), in accordance with the European standard EN 1717.
- The second socket allows water sampling of the downstream user system, as well as checking the system pressure conditions (using a pressure gauge with G 1/4" connection).



3681
Anti-pollution controllable check valves EA Type

 Controllable (EA Type)

Code	Type	Price €	Unit/Box
350 0346	3/4"		10/50
350 0347	1"		10/50

07_B CHECK VALVES

SWING CHECK VALVES



3660
Swing check valve FULL ISO228 female/female with brass shutter with gasket



Code	Type	Price €	Unit/Box
350 0015	1/2"		25/75
350 0016	3/4"		15/45
350 0009	1"		10/30
350 0017	1"1/4		5/20
350 0020	1"1/2		5/15
350 0011	2"		2/12
350 0028	2"1/2		1/5
350 0026	3"		1/3
350 0042	4"		1/2



3665
Swing check valve FULL ISO228 female/female with brass shutter without gasket



Code	Type	Price €	Unit/Box
350 0135	1/2"		25/75
350 0136	3/4"		15/45
350 0137	1"		10/30
350 0138	1"1/4		5/25
350 0139	1"1/2		5/15
350 0140	2"		2/12
350 0343	2"1/2		1/5
350 0344	3"		1/3
350 0345	4"		1/2



The BA-type preventers are characterized by a controllable low pressure zone connected to a drain located between the two check valves located upstream and downstream of the device.

The two check valves delimit three different pressure zones each with a pressure plug.

OPERATION

NORMAL OPERATION: FAULT-FREE FLOW

The primary network pressure overcomes the resistance of the two check valves (R1 and R2), allowing the various users to be supplied. Due to the pressure drop of the R1 valve, the pressure in the intermediate zone is at least 140 mibar lower than the upstream pressure. This pressure difference acts on the membrane, hindering the return force of the spring which would tend to open the S discharge valve.

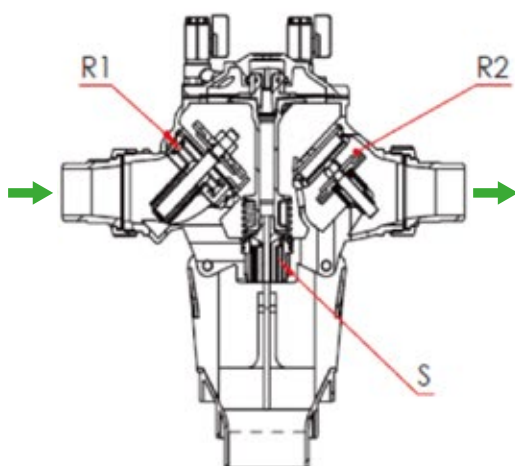

FLOW STOP: STATIC PRESSURE

Check valves (R1 and R2) close; the discharge valve remains closed.

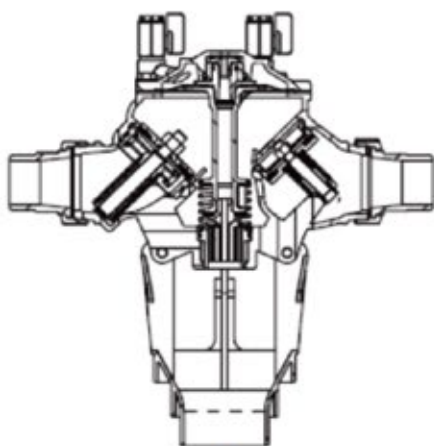

FLOW FAULT: DOWNSTREAM OVERPRESSURE

Downstream check valve (R2) closes preventing contaminated water from flowing into the primary network. If the downstream check valve is not sealing correctly, contaminated water may leak into the center chamber; the pressure in the center chamber may increase, causing the valve shutter to open and the contaminated water to drop.

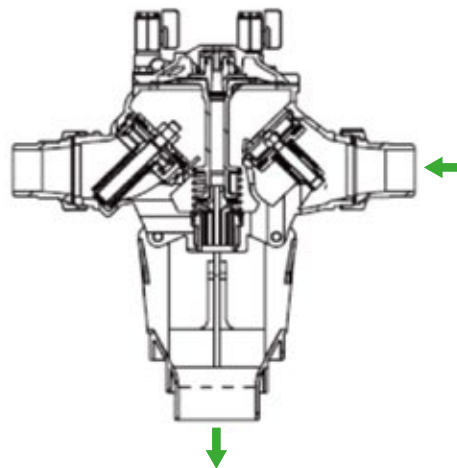

FLOW FAULT: UPSTREAM PRESSURE DROP (SIPHONING)

If the upstream pressure drops accidentally, the check valves (R1 and R2) close automatically; this cancels the pressure difference between the upstream and central zones; the spring return force causes the valve shutter to open and the central zone to empty out. The flow between the upstream and downstream zones is thus interrupted, for a complete safety. Emptying the center zone causes the pressure to decrease and returns the device to its initial safe condition.

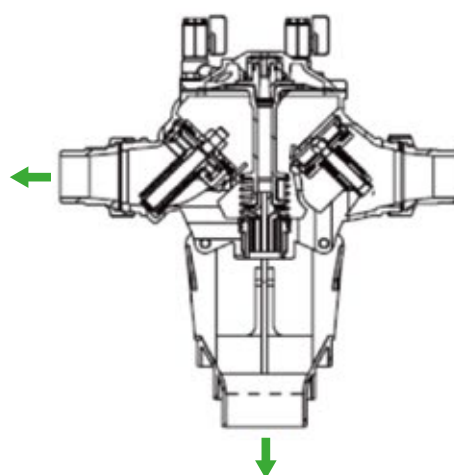



3501
Controllable BA-type low pressure backflow preventer

TECHNICAL SPECIFICATIONS:

- ISO 228 threads
- Body material: Brass CW 602N (1/2" – 3/4"); Bronze (> 1")
- BA-type according to EN 1717
- Against the risk of contamination with water up to category 4

Code	Type	Price €	Unit/Box
350 0296	1/2"		1/1
350 0297	3/4"		1/1
350 0298	1"		1/1
350 0299	1"1/4		1/1
350 0300	1"1/2		1/1
350 0301	2"		1/1

3501

INSTALLATION EXAMPLE

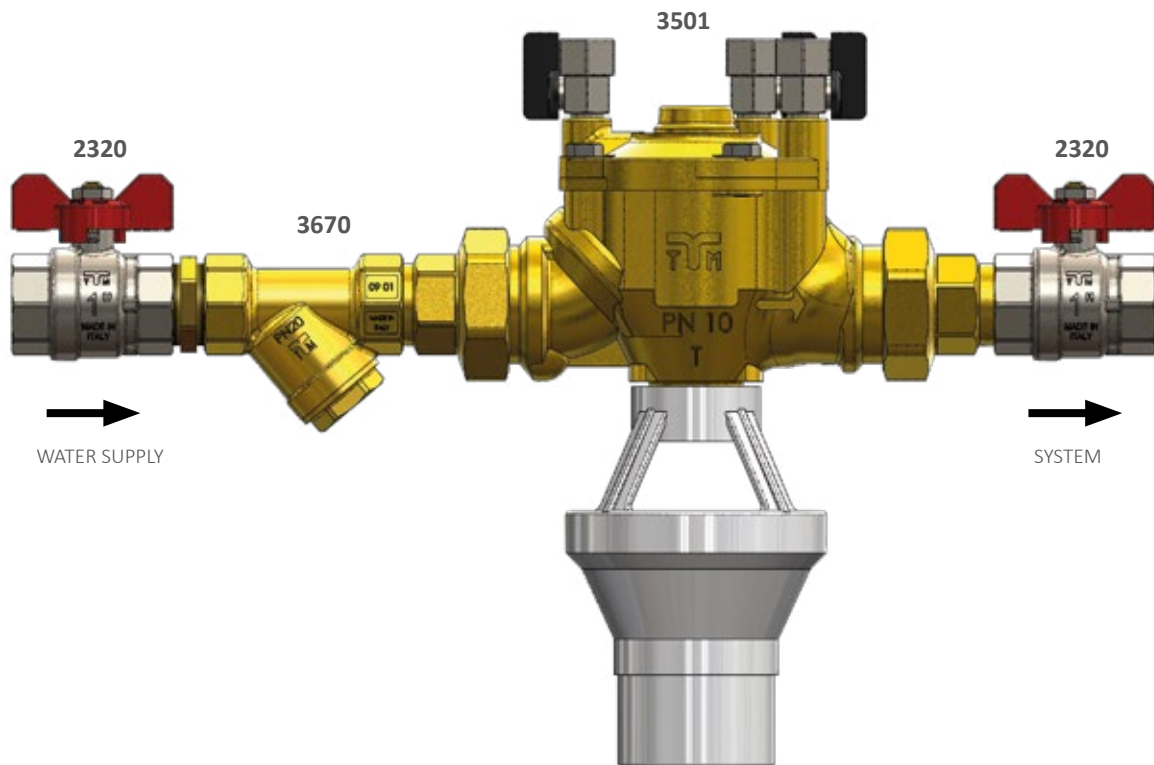

08

"TIEMME BOX" FLUSH-MOUNTED MODULES FOR ONE RADIANT AREA ADJUSTMENT

08A TIEMME BOX



148

The TIEMME BOX modules ensure the connection and regulation of the temperature of a single zone of the heating system on floor or wall without the aid of mixing valves or pumping stations, even in centralized systems. Being able to adjust and regulate with precision the single user has as final result not only in the comfort of the rooms, but also on the consumption, reducing both energy and thermal consumption.

ADVANTAGES / STRENGTHS

- **Fast:** installed directly on the existing system requiring no invasive and expensive interventions.
- **Inexpensive:** the most economical choice for radiant heating circuits.
- **Self-contained:** does not use electricity, so no electrical installation is necessary.
- **Simple:** no mixing valve or assembly required and is intuitively set.
- **Versatile:** can be used both in new systems as well as renovations.
- **Elegant:** clean and elegant design in white or chrome versions.

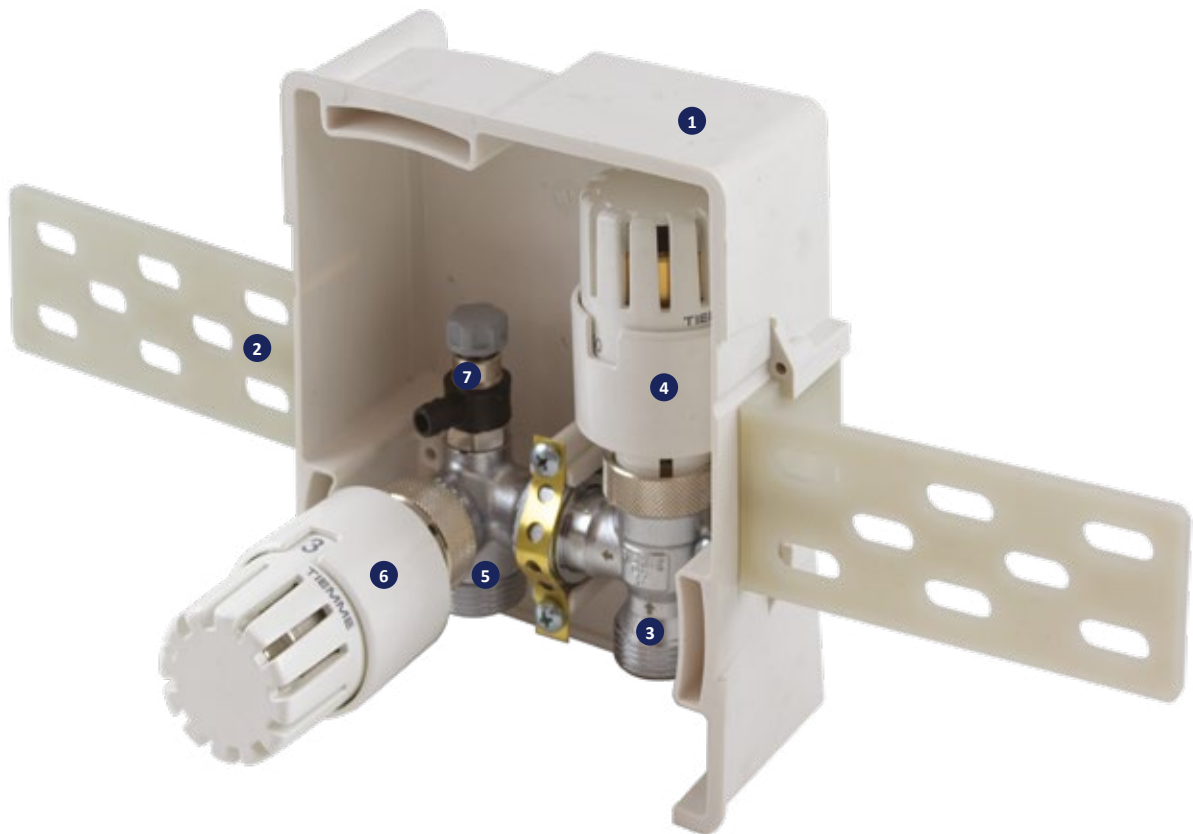

1. Storage box
2. Mounting bracket
3. Thermostatic valve (RTL)
4. RTL Return temperature Limiter
5. Thermostatic valve with pre-adjustment
6. Thermostatic head
7. Vent



PRODUCT RANGE



4490

TIEMME BOX 1 for heating adjustment based on room temperature

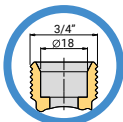

TECHNICAL SPECIFICATIONS:

- Max. operating temperature: 90°C
- Max operating pressure: 10 bar
- Room temperature adjustment range: 6 ÷ 28 °C
- Valve body material: Brass CW617N
- Thermostatic valve with pre-adjustment (kV): 0,09 ÷ 0,8 m³/h (6 positions)

Code	Type	Price €	Unit/Box
449 0001	3/4" (ø18)		1/4



4490C

TIEMME BOX 1 for heating adjustment based on room temperature Chrome version

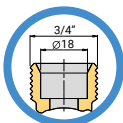

TECHNICAL SPECIFICATIONS:

- Max. operating temperature: 90°C
- Max operating pressure: 10 bar
- Room temperature adjustment range: 6 ÷ 28 °C
- Valve body material: Brass CW617N
- Thermostatic valve with pre-adjustment (kV): 0,09 ÷ 0,8 m³/h (6 positions)

Code	Type	Price €	Unit/Box
449 0021	3/4" (ø18)		1/4

OPERATION

The room temperature is adjusted by a thermostatic valve with continuous proportional regulation (art. 9553) included in the box. As the room temperature increases or decreases, the shut-off valve inside the TIEMME BOX opens or closes respectively. Once the desired room temperature is reached, the circuit fully closes. In the event of a drop in room temperature, the circuit is re-opened to allow the heating fluid to pass through again.

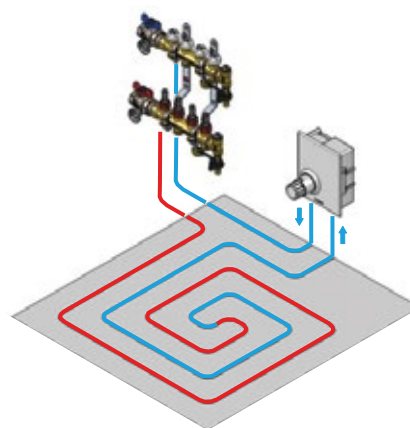

DIMENSIONS

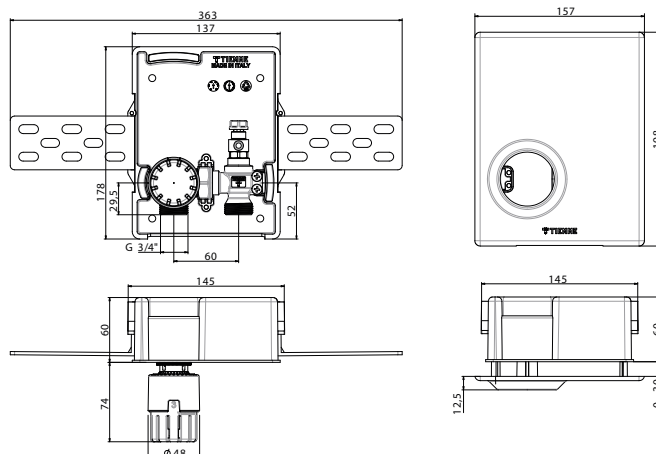

PRODUCT RANGE



4491

TIEMME BOX 2 to limit the return temperature of the heating circuit (RTL)

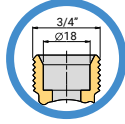

TECHNICAL SPECIFICATIONS:

- Max. operating temperature: 90°C
- Max operating pressure: 10 bar
- Room return temperature adjustment range: 0 ÷ 50 °C
- Valve body material: Brass CW617N

Code	Type	Price €	Unit/Box
449 0002	3/4" (Ø18)		1/4



4491C

TIEMME BOX 2 to limit the return temperature of the heating circuit (RTL) Chrome version

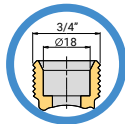

TECHNICAL SPECIFICATIONS:

- Max. operating temperature: 90°C
- Max operating pressure: 10 bar
- Room return temperature adjustment range: 0 ÷ 50 °C
- Valve body material: Brass CW617N

Code	Type	Price €	Unit/Box
449 0022	3/4" (Ø18)		1/4

OPERATION

The room temperature is adjusted by limiting the temperature of the heating system return fluid using a special proportional thermostatic valve (RTL) in contact with the fluid (thermal conduction). Once the desired temperature has been set, the fluid flow will be closed every time the fluid flow value is above the set limit and will be re-opened as the fluid temperature drops.

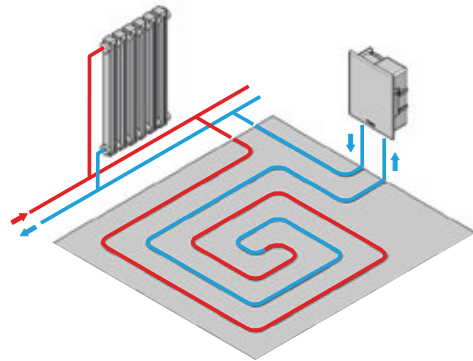

DIMENSIONS

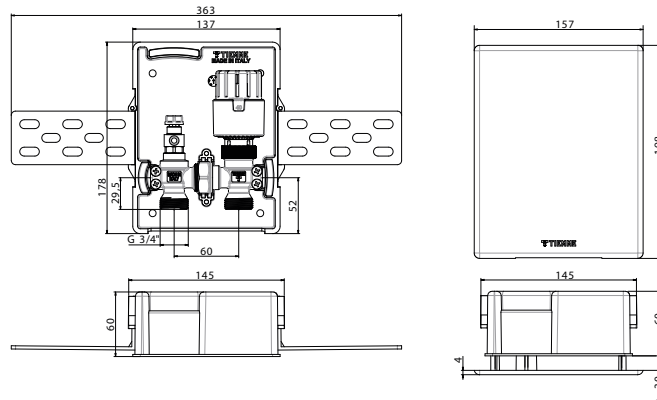

PRODUCT RANGE



4492

TIEMME BOX 3 for heating adjustment based on room temperature and return temperature limitation (RTL)

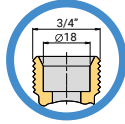

TECHNICAL SPECIFICATIONS:

- Max. operating temperature: 90°C
- Max operating pressure: 10 bar
- Room temperature adjustment range: 6 ÷ 28 °C
- Room return temperature adjustment range: 0 ÷ 50 °C
- Valve body material: Brass CW617N
- Thermostatic valve with pre-adjustment (kV): 0,09 ÷ 0,8 m³/h (6 positions)

Code	Type	Price €	Unit/Box
449 0003	3/4" (Ø18)		1/4



4492C

TIEMME BOX 3 for heating adjustment based on room temperature and return temperature limitation (RTL)
Chrome version



TECHNICAL SPECIFICATIONS:

- Max. operating temperature: 90°C
- Max operating pressure: 10 bar
- Room temperature adjustment range: 6 ÷ 28 °C
- Room return temperature adjustment range: 0 ÷ 50 °C
- Valve body material: Brass CW617N
- Thermostatic valve with pre-adjustment (kV): 0,09 ÷ 0,8 m³/h (6 positions)

Code	Type	Price €	Unit/Box
449 0023	3/4" (Ø18)		1/4

OPERATION

The room temperature is adjusted by a thermostatic valve with continuous proportional regulation (art. 9553) included in the box. As the room temperature increases or decreases, the shut-off valve inside the TIEMME BOX opens or closes respectively. Once the desired room temperature is reached, the circuit fully closes. In the event of a drop in room temperature, the circuit is re-opened to allow the heating fluid to pass through again.

The temperature of the heating system fluid is regulated by the use of a thermostatic valve with continuous proportional regulation by thermal conduction.

Once the desired temperature for the return fluid of the system has been set, by rotating the knob of the thermostatic head, the fluid flow will be closed every time the temperature is above the set limit and will consequently be re-opened when the temperature of the fluid drops.

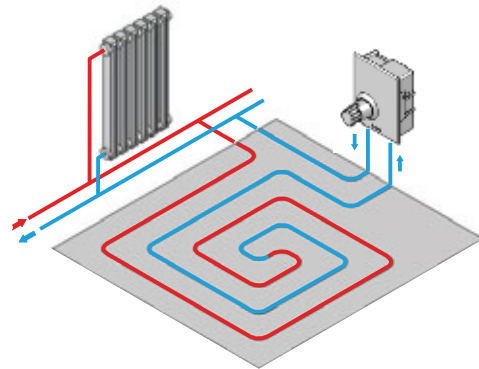

DIMENSIONS

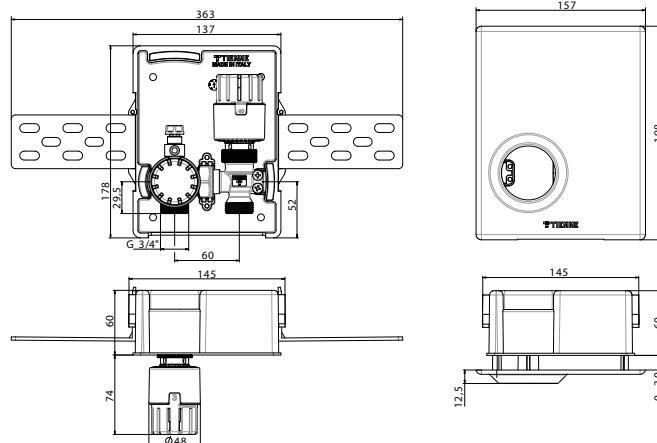

09A	Hydraulic power units for solar heating systems		154
09B	Accessories for hydraulic power units		155
09C	Components for solar heating systems		157
09D	Quick-coupling fittings "COBRASUN"		164
09E	Quick-coupling fittings "EASYSOLAR"		167
09F	Fittings for copper pipe and corrugated stainless steel pipe		169
09G	Stainless steel corrugated pipe and accessories		176



4745

Double hydraulic power unit for solar heating systems with insulation included. Version with deaerator, ball valve with integrated thermometer, 6 bar safety unit and mechanical flowmeter

TECHNICAL SPECIFICATIONS

- Size: DN 25-1"
- Connection: 3/4" F
- Max pressure: 10 bar
- Max temperature: 160°C
- Special metals: brass CW 617N
- Gasket material: EPDM Perox; Fluoroelastomer rubber
- Insulation material: EPP

Code	Circulation pump	Flowmeter	Price €	Unit/Box
470 0408	Grundfos solar UPM3 15/75	1÷10 l/min		1/1
470 0409		8÷30 l/min		1/1
470 0379	Wilo Para ST 15/7.0	1÷10 l/min		1/1
470 0380		8÷30 l/min		1/1
470 0232	Grundfos solar 15/65	1÷10 l/min		1/1
470 0233		8÷30 l/min		1/1

ErP READY

Available to countries outside the EU



4745E

Double hydraulic power unit for solar heating systems with insulation included. Version with deaerator, ball valve with integrated thermometer, 6 bar safety unit and mechanical flowmeter (Vortex)



TECHNICAL SPECIFICATIONS

- Size: DN 25-1"
- Connection: 3/4" F
- Max pressure: 10 bar
- Max temperature: 160°C
- Special metal material: brass CW 617N
- Gasket material: EPDM Perox; Fluoroelastomer rubber
- Insulation material: EPP

ELECTRONIC FLOWMETER

Code	Circulation pump	Flowmeter	Price €	Unit/Box
470 0410	Grundfos solar UPM3 15/75	2÷40 l/min		1/1
470 0381	Wilo Para ST 15/7.0	2÷40 l/min		1/1

ErP READY



4745R

Double hydraulic power unit for solar heating system. Preset insulation for regulator housing 4735E

TECHNICAL SPECIFICATIONS

- Size: DN 25-1"
- Connection: 3/4" F
- Max pressure: 10 bar
- Max temperature: 160°C
- Special metal material: brass CW 617N
- Gasket material: EPDM Perox; Fluoroelastomer rubber
- Insulation material: EPP

Code	Circulation pump	Flowmeter	Price €	Unit/Box
470 0416	Wilo Para ST 15/7.0	1÷10 l/min		1/1
470 0417		8÷30 l/min		1/1
470 0275	Grundfos solar 15/65	1÷10 l/min		1/1
470 0276		8÷30 l/min		1/1

ErP READY

Available to countries outside the EU



4744

Single line hydraulic power unit for solar heating systems with insulation included. Version with ball valve with integrated thermometer, 6 bar safety unit and mechanical flowmeter

TECHNICAL SPECIFICATIONS

- Size: DN 25-1"
- Connection: 3/4" F
- Max pressure: 10 bar
- Max temperature: 160°C
- Special metal material: brass CW 617N
- Gasket material: EPDM Perox; Fluoroelastomer rubber
- Insulation material: EPP

Code	Circulation pump	Flowmeter	Price €	Unit/Box
470 0411	Grundfos solar UPM3 15/75	1÷10 l/min		1/1
470 0382	Wilo Para ST 15/7.0	1÷10 l/min		1/1
470 0257	Grundfos solar 15/65	1÷10 l/min		1/1

ErP READY

Available to countries outside the EU





4735E

Programmable electronic temperature controller for solar systems, large LCD display

Code	Input	Output	Sensor	Price €	Unit/Box
470 0516	3	1	2		1/4
470 0517	4	2	3		1/4
470 0518	6	3	4		1/4

New code

With input for electronic flowmeter art. 4749E - 4749FLOWE



4745C

PPE frame for electronic regulator

Code	Type	Price €	Unit/Box
470 0533	For 470 0516		1/10
470 0286	For 470 0517 - 470 0518		1/10
470 0321	Closed		1/10

New code

4745C

CONFIGURATIONS



470 0533



470 0286



470 0321



4736SONDA

PT1000 temperature probe, two-metre silicone cable, steel probe 6x25mm

Code	Size	Price €	Unit/Box
470 0027	-		1/50



4747

Deaerator for hydraulic power unit with 3/4" M/M fittings with pre-seal

Code	Type	Price €	Unit/Box
470 0057	3/4"		1/20



4748D

Safety unit with 1-10 bar manometer and 6 bar safety valve

Code	Type	Price €	Unit/Box
470 0227	-		1/10



4749FLOW

Filling/drainage unit with built-in mechanical flowmeter for solar heating systems

Code	Type	Price €	Unit/Box
470 0267	1" F x 3/4" F - 1÷10 l/min		1/5
470 0268	1" F x 3/4" F - 8÷30 l/min		1/5



4749FLOWE

Filling/drainage unit with built-in electronic flowmeter (Vortex) for solar heating systems

+ ELECTRONIC FLOWMETER			
Code	Type	Price €	Unit/Box
470 0269	1" F x 3/4" F - 2÷40 l/min		1/5



6531G
Balancing valve with flow meter

Code	Type	Price €	Unit/Box
651 0002	1" - 4÷15 l/min		1/25
651 0003	1" - 8÷30 l/min		1/25
651 0004	1" - 10÷40 l/min		1/25



4749E
Sensor for electronic flowmeter

Code	Type	Price €	Unit/Box
470 0272	2÷40 l/min		1/5



4745MANOP
Knob with immersion thermometer for hydraulic power units

Code	Type	Price €	Unit/Box
470 0183	Blue		10/40
470 0184	Red		10/40



3890PG4
GRUNDFOS Solar UPM3 PM 15/75 high efficiency pump with PWM control and 130 mm interaxle

+ HIGH EFFICIENCY PUMP

Code	Type	Price €	Unit/Box
470 0407	Grundfos Solar UPM3 15/75-130		1/1



3890PW4
Wilo Para ST 15/7.0 high efficiency pump with PWM control. 1" and 130 mm interaxle fittings

+ HIGH EFFICIENCY PUMP

Code	Type	Price €	Unit/Box
470 0378	Wilo Para ST 15/7.0		1/1



3890PG3
Grundfos Solar 16/65 3-speed pump for solar systems. 1" and 130 mm interaxle fittings

Code	Type	Price €	Unit/Box
470 0224	Grundfos solar 15/65		1/1

Available to countries outside the EU





2330SUN

Ball valve female/female connections with orange plastic flat handle. Maximum temperature 180°C

Code	Type	Price €	Unit/Box
472 0012	1/2"		25/100
472 0008	3/4"		15/60
472 0015	1"		10/40



2162SUN

Ball valve with fittings for copper pipe and flat orange handle. Maximum temperature 180°C

Code	Type	Price €	Unit/Box
472 0074	15		15/60
472 0075	18		15/60
472 0076	22		10/40
472 0077	28		7/28



2331SUN

Ball valve male/female connections with orange plastic flat handle. Maximum temperature 180°C

Code	Type	Price €	Unit/Box
472 0018	1/2"		25/100
472 0010	3/4"		15/60
472 0014	1"		10/40



2371SUN

Ball valve male/female connections with orange t-handle. Maximum temperature 180°C

Code	Type	Price €	Unit/Box
472 0007	1/2"		25/100



2991SUN

Ball cock fill/drain for high temperatures. 1/2" fitting with pre-seal

Code	Type	Price €	Unit/Box
472 0019	1/2"		25/100



3506SUN

EUROSTOP check valve female connections ISO 228 with metal shutter and high temperature gaskets

Code	Type	Price €	Unit/Box
472 0082	1/2"		15/60
472 0083	3/4"		10/40
472 0084	1"		6/24
472 0085	1"1/4		5/20
472 0086	1"1/2		2/8
472 0087	2"		2/8



1900SUN

Automatic air vent valve with o-ring seal. Maximum temperature 180°C

Code	Type	Price €	Unit/Box
472 0001	1/2"		1/50



1900KITSUN

Automatic air vent valve with ball valve. Maximum temperature 180°C

Code	Type	Price €	Unit/Box
472 0004	1/2"		2/20



1917SUN 1927SUN

Safety valve for solar heating systems. Max temperature max 160°C. Nominal pressure 10 bar
Female connecting thread ISO7

Code	Type	Calibration	Price €	Unit/Box
472 0089	1/2" x 1/2"	2,5 bar		1/40
472 0080	1/2" x 3/4"	2,5 bar		1/40
472 0011	1/2" 3/4"	3 bar		1/40
472 0006	1/2" 3/4"	6 bar		1/40

NEW



3177XSUN

Safety group suitable for hot water storage heaters for solar thermal systems

Code	Type	Calibration	Price €	Unit/Box
319 0018	3/4" x 3/4"	10 bar		1/20



1916SUN

Temperature and pressure relief valve for solar system with male fitting/copper pipe outlet connection

+ PRESSURE-TEMPERATURE CONTROL

Code	Size	Calibration	Price €	Unit/Box
472 0088	3/4" x 22	10 bar		1/10





4737SUN

Chrome-plated thermostatic mixing valve F for solar heating systems

TECHNICAL SPECIFICATIONS

- Compliance with: UNI EN 1111
- Temperature range: 30÷55°C
- Max operating pressure: 10 bar
- Max inlet temperature: 100°C
- Body material: brass CW617N
- Handle material: PA
- Flow rate at 3 bar: 30 l/min

Code	Type	Price €	Unit/Box
470 0456	1/2"		1/10
470 0457	3/4"		1/10



4739SUN

Chrome-plated thermostatic mixing valve, male pipe union attachments, for solar heating systems

TECHNICAL SPECIFICATIONS

- Compliance with: UNI EN 1111
- Temperature range: 30÷55°C
- Max operating pressure: 10 bar
- Max inlet temperature: 100°C
- Body material: brass CW617N
- Knob material: PA
- Flow rate at 3 bar: 30 l/min

Code	Type	Price €	Unit/Box
470 0459	1/2"		1/10
470 0460	1/2" with non-return valve		1/10
470 0476	3/4"		1/10
470 0477	3/4" with non-return valve		1/10



4738SUN

Chrome-plated thermostatic mixing valve M for solar heating systems

TECHNICAL SPECIFICATIONS

- Compliance with: UNI EN 1111
- Temperature range: 30÷55°C
- Max operating pressure: 10 bar
- Max inlet temperature: 100°C
- Body material: brass CW617N
- Knob material: PA
- Flow rate at 3 bar: 30 l/min (3/4") - 72 l/min (1")

Code	Type	Price €	Unit/Box
470 0458	3/4"		1/10
470 0188	1"		1/10



4738KIT

Thermostatic mixing valve fittings kit

i The kit includes: 3 tails, 3 nuts and 3 gaskets

Code	Type	Price €	Unit/Box
For 4738SUN (3/4")			
470 0454	3/4" x 1/2"		1/10
470 0455	3/4" x 1/2" with non-return valve		1/10
470 0475	3/4" x 3/4"		1/10
470 0474	3/4" x 3/4" with non-return valve		1/10
For 4738SUN (1")			
470 0190	1" x 3/4"		1/10
470 0191	1" x 3/4" with non-return valve		1/10
470 0192	copper fitting Ø22 compression		1/10



4738GSUN

Thermostatic mixing valve for solar heating systems - high flow rate

TECHNICAL SPECIFICATIONS

- Temperature range: 30÷65°C
- Max operating pressure: 10 bar
- Max inlet temperature: 100°C
- Body material: brass CW625N
- Handle material: PA
- Minimum flow rate for correct functioning:
12 l/min. (1"1/4) - 15 l/min. (1"1/2) 25 l/min. (2") - 30 l/min. (2"1/2)

+ DEZINCIFICATION-RESISTANT

Code	Type	Price €	Unit/Box
470 0469	1" 1/4		1/8
470 0470	1" 1/2		1/8
470 0471	2"		1/3
470 0473	2" 1/2		1/3



1521CPKIT

Union kit

i The kit includes: 3 tails, 3 nuts and 3 gaskets

Code	Type	Price €	Unit/Box
150 1013	1"1/4 F x 1" M		1/15
150 1014	1"1/2 F x 1"1/4 M		1/10
150 1015	2" F x 1"1/2 M		1/10
150 1016	2"1/2 F x 2" M		1/5

Diverter/thermostatic mixing valve connection kit for solar store-heater art. 475KIT is a strong option for integrating the domestic hot water production of a solar panel system with an instant water boiler or with a store.

Allows better management of thermal energy contained in a solar storage tank, by regulating and distributing water in the system network at an ideal temperature, without wastage and guaranteeing savings.

Differing sunlight conditions sometimes lead to water being present in the store at temperatures which are too high, in which case it becomes necessary to mix it to lower the usage temperature, thereby avoiding dangerous scalding.

Alternatively, in situations of inadequate insulation the temperature of water in the boiler is too low and it becomes necessary to bring the temperature up through with the intervention of a heat generator (boiler or water heater).

The kit developed by Tiemme means maintaining the domestic hot water performance temperature at a constant (adjustable using the thermostatic mixing valve), **automatically managing boiler intervention** (function incurred by the thermostatic mixing valve) **when inadequate sunlight conditions warrant it.**

STRENGTHS

- Two functions performed by a single product: ensuring comfort in hot water performance and economic savings thanks to the improvement in the system's energy efficiency.
- Adjustable diverter valve
- Thermostatic mixing valve with anti-scald function
- Application in solar heating systems: resistant to high temperatures in continuous operation.
- Compact and easy to install in new or existing systems.
- Equipped with built-in check valve on the inlet fittings
- Horizontal or vertical installation positioning
- Replaceable cartridges for thermostatic mixing valves and diverter valves.

OPERATION

If the incoming water originating from the solar store is not hot enough (temperature of water from store < diverter valve calibration value), it will be diverted via the thermostatic diverter valve towards the generator (wall-mounted boiler or water heater), accordingly, once it reaches temperature, it will be mixed to the desired temperature via the thermostatic mixing valve (settable adjustment range +30 ÷ +55 °C) **(Diagram 1).**

In the opposite scenario, if the water present in the solar store is already hot enough (temperature of water from store > diverter valve calibration value), it will be diverted straight to the thermostatic mixing valve, bypassing the generator **(Diagram 2).**

DIAGRAM 1: T < Diverter calibration value

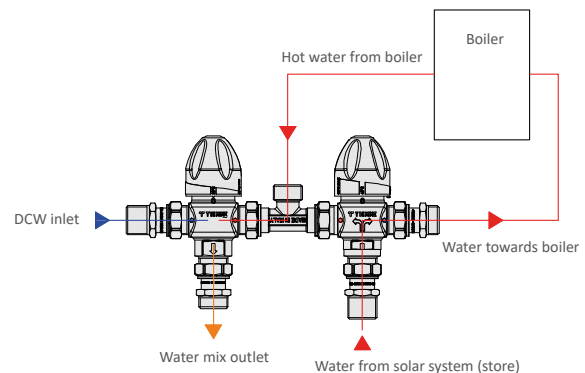
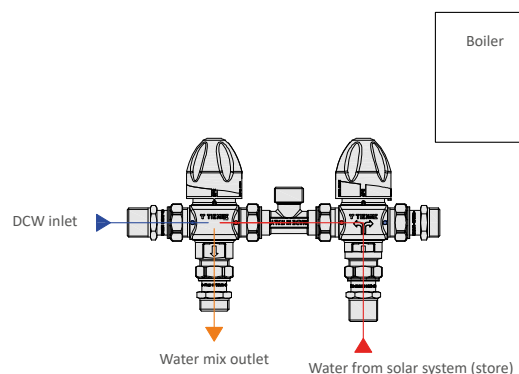

DIAGRAM 2: T > Diverter calibration value



09_c COMPONENTS FOR SOLAR HEATING SYSTEMS

DIVERTER/THERMOSTATIC MIXING VALVE CONNECTION KIT SOLAR STORE-BOILER

PRODUCT RANGE



475KIT

Diverter/thermostatic mixing valve connection kit for solar store-heater.

MANUFACTURING SPECIFICATIONS

- Body: Chrome plated brass CW617N
- Adjusting handwheel PA

TECHNICAL SPECIFICATIONS

THERMOSTATIC DIVERTER VALVE

- Maximum inlet temperature: +100°C
- Maximum operating pressure: 10 bar
- Maximum differential pressure: 2 bar
- Temperature adjustment range: +30 ÷ +55 °C
- Factory setting: +45°C
- Accuracy: ±2 °C
- Fluid compatibility Potable water

ANTI-SCALD THERMOSTATIC MIXING VALVE

- Maximum inlet temperature: +100°C
- Maximum operating pressure: 10 bar
- Maximum differential pressure: 2 bar
- Temperature adjustment range: +30 ÷ +55 °C
- Factory setting: +38°C
- Accuracy: ±2 °C
- Fluid compatibility Potable water
- Flow rate at 3 bar: 30 l/min.
- Compliance: UNI EN 1111

Code	Type	Price €	Unit/Box
475 0050	3/4"		1/8

ACCESSORIES AND SPARE PARTS



475KITISOL

Insulation shell for 5-way solar kit with diverter and thermostatic mixing valve

Code	Type	Price €	Unit/Box
470 0463	475KIT		1/8

INSTALLATION EXAMPLE

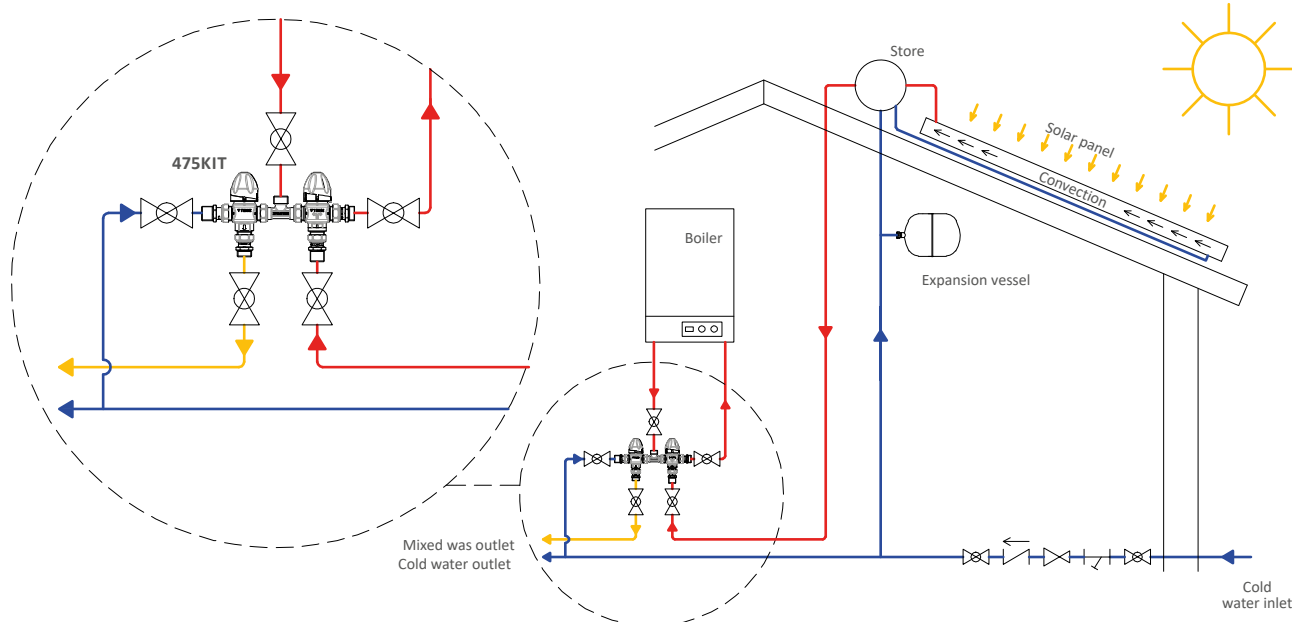

THERMOSTATIC DIVERTER VALVE

Thermostatic diverter valve for solar heating systems art. 3894VDSUN carries out the function of diverting the fluid in two possible directions - on the basis of the inlet water temperature and the set temperature value.

The function of the diverter is incurred by the thermostatic element which in contact with water undergoes a volume change that determines the diversion of the outgoing water.

Field of application: Used in solar systems with the function of diverting water from the store directly to utilities or to a boiler for integration. Differing sunlight conditions sometimes lead to water being present in the store at temperatures which are already suitable for distribution to utilities. Alternatively, in situations of inadequate insulation the temperature of water in the boiler is too low and it becomes necessary to bring the temperature up with the intervention of a heat generator (boiler or water heater).

The diverter valve developed by Tiemme means automatically managing boiler intervention when inadequate sunlight conditions warrant it.

ADVANTAGES / STRENGTHS

- Adjustable temperature range
- Application in solar heating systems: resistant to high temperatures in continuous operation.
- Horizontal or vertical installation positioning
- Built-in thermostatic sensor (immersed in water flow).
- Replaceable cartridge.

PRODUCT RANGE



3894VDSUN

Thermostatic diverter valve M for solar heating systems.

TECHNICAL SPECIFICATIONS

- Temperature range: 30÷55°C
- Max operating pressure: 10 bar
- Max differential pressure: 2 bar
- Max inlet temperature: 100°C
- Body material: brass CW 617N
- Knob material: PA

Code	Type	Price €	Unit/Box
470 0453	3/4"		1/10

OPERATION

If the incoming water is not hot enough (temperature of water < diverter valve calibration value), it will be diverted to the generator (**Diagram 1**).

In the opposite scenario, if the water is already hot enough (temperature of water > diverter valve calibration value), it will be diverted straight to the utilities (**Diagram 2**).

Diagram 1: T < diverter calibration value

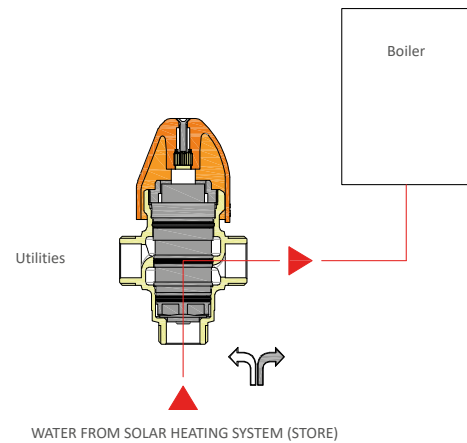
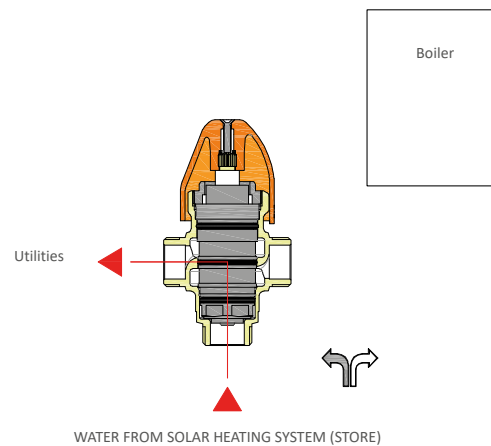

Diagram 2: T > diverter calibration value





2134SUN
3-way motorized ball diverter valve - 3 union fitting

Code	Type	Supply	Price €	Unit/Box
472 0009	3/4"	230 VAC		1/4
472 0013	1"	230 Vac		1/4



4731ANTIG
Anti-freeze for mixing for solar systems

Code	Litres	Price €	Unit/Box
470 0026	10		1/1



4730V
Preset 3 bar expansion vessel

Code	Capacity	Price €	Unit/Box
470 0031	18 l		1/1
470 0045	24 l		1/1
470 0066	35 l		1/1
470 0055	50 l		1/1



4746KIT
Expansion vessel connection kit

Code	Type	Price €	Unit/Box
470 0041	3/4"		1/10



4746
Non-return valve for expansion vessel 3/4"M - 3/4"F fitting

Code	Type	Price €	Unit/Box
470 0028	3/4" M - 3/4" F		5/50



3000X
Straight union male

PATENTED

Code	Type	Price €	Unit/Box
071 0102	DN12 X 1/2" M		4/40
071 0082	DN12 x 3/4" M		4/40
071 0036	DN16 x 1/2" M		4/40
071 0037	DN16 x 3/4" M		4/40
071 0038	DN16 x 1" M		4/40
071 0039	DN20 x 3/4" M		4/40
071 0040	DN20 x 1" M		4/40
071 0041	DN25 x 1" M		4/40
071 0042	DN25 x 1"1/4 M		4/40
071 0083	DN32 x 1"1/4 M		4/40
071 0084	DN40 x 1"1/2 M		4/40
071 0085	DN40 x 2" M		4/40



3002X
Straight fitting female

PATENTED

Code	Type	Price €	Unit/Box
071 0103	DN12 x 1/2" F		4/40
071 0087	DN12 x 3/4" F		4/40
071 0050	DN16 x 1/2" F		4/40
071 0051	DN16 x 3/4" F		4/40
071 0052	DN16 x 1" F		4/40
071 0053	DN20 x 3/4" F		4/40
071 0054	DN20 x 1" F		4/40
071 0055	DN25 x 1" F		4/40
071 0088	DN32 x 1"1/4 F		4/40
071 0089	DN40 x 1"1/2 F		4/40
071 0090	DN40 x 2" F		4/40



3001X
Double union fitting

PATENTED

Code	Type	Price €	Unit/Box
071 0086	DN12 x DN12		4/40
071 0043	DN16 x DN16		4/40
071 0044	DN20 x DN20		4/40
071 0045	DN25 x DN25		4/40



3001KB
Double union stainless steel/
copper

PATENTED

Code	Type	Price €	Unit/Box
071 0130	DN12x12 (Cu)		4/40
071 0046	DN16 x 15 (Cu)		4/40
071 0047	DN16 x 22/18 (Cu)		4/40
071 0048	DN20 x 22/18 (Cu)		4/40
071 0049	DN25 x 22/18 (Cu)		4/40

Supplied with bushing adapter 22/18



3011X
Straight fitting stainless steel
pipe/cylindrical pipe

PATENTED

Code	Type	Price €	Unit/Box
071 0091	DN16 x Ø 18		4/40
071 0056	DN16 x Ø 22		4/40
071 0092	DN20 x Ø 18		4/40
071 0093	DN20 x Ø 22		4/40
071 0094	DN25 x Ø 18		4/40
071 0095	DN25 x Ø 22		4/40



09_D QUICK-COUPLING "COBRASUN" FITTINGS FOR STAINLESS STEEL CORRUGATED PIPE



3004X
Elbow fitting male

PATENTED

Code	Type	Price €	Unit/Box
071 0129	DN16 x 3/4" M		4/40



3005X
Elbow fitting female



PATENTED/PATENTED

Code	Type	Price €	Unit/Box
071 0078	DN16 x 3/4" F		4/40



3003KB
Double bend fitting stainless steel/copper



PATENTED

Code	Type	Price €	Unit/Box
071 0133	DN16 x 18 (Cu)		4/40
071 0079	DN16 x 22 (Cu)		4/40



3007KB
Tee fitting copper/stainless steel/copper



PATENTED

Code	Type	Price €	Unit/Box
071 0080	22 (Cu) x DN16 x 22 (Cu)		4/40



3015
Olive

PATENTED

Code	Type	Price €	Unit/Box
071 0104	DN12		50/1000
071 0105	DN16		50/1000
071 0106	DN20		50/1000
071 0107	DN25		50/1000
071 0155	DN32		50/1000

COMPATIBILITY TABLE CORRUGATED STAINLESS STEEL PIPE

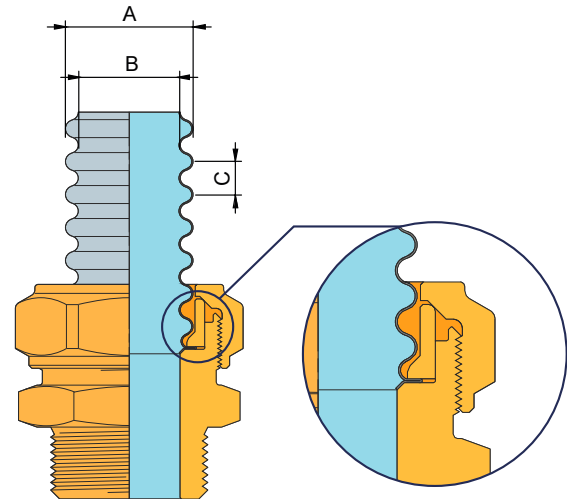

RECOMMENDED PIPE SIZE

DN*	A	B	C
12	16,5 ± 0,10	12.5 ± 0.50	4 ± 0.50
16	21.4 ± 0.20	16.8 ± 0.50	5 ± 0.50
20	26.4 ± 0.20	20.8 ± 0.50	5 ± 0.50
25	31.7 ± 0.25	25.5 ± 0.50	5 ± 0.50
32	40.7 ± 0.35	35 ± 0.50	5 ± 0.70
40	49 ± 0.45	40.5 ± 0.50	6.5 ± 0.70

*For different diameters please contact our Technical Department

VIDEO TUTORIAL



Installation guide

INSTALLATION GUIDE

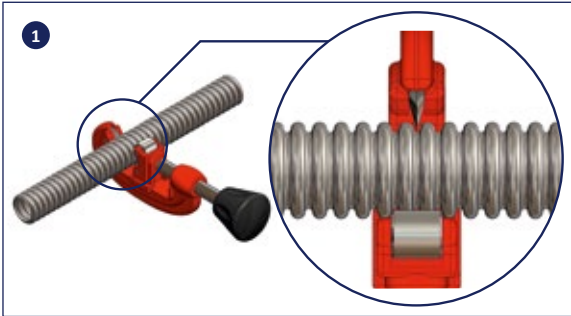

Set the edge in the groove perpendicular to the pipe. Cut should be neat, without rough edges

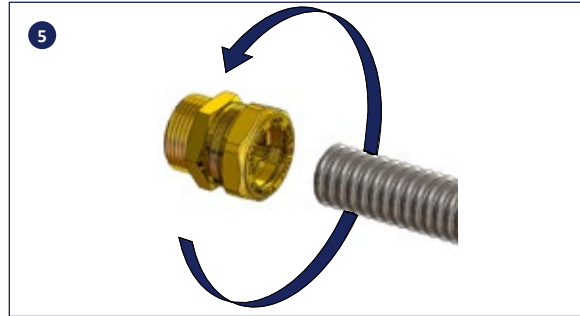

Manually loosen nut approx. 1/2 turn, if not already loosened

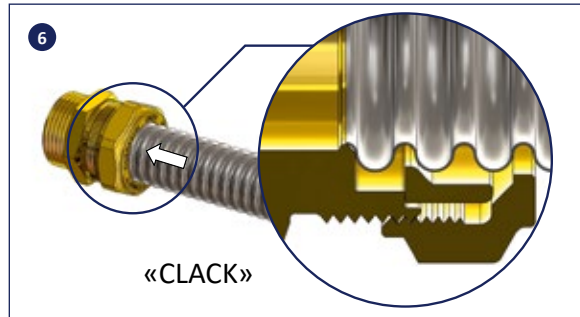

Push the pipe into the fitting until it goes "CLICK"

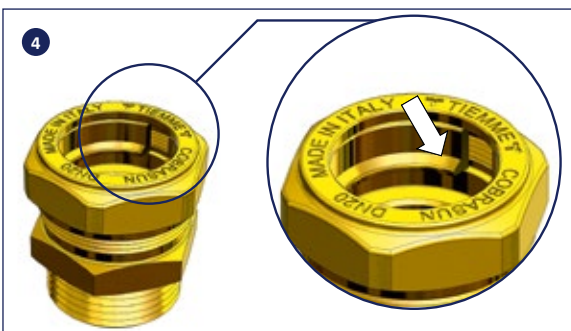
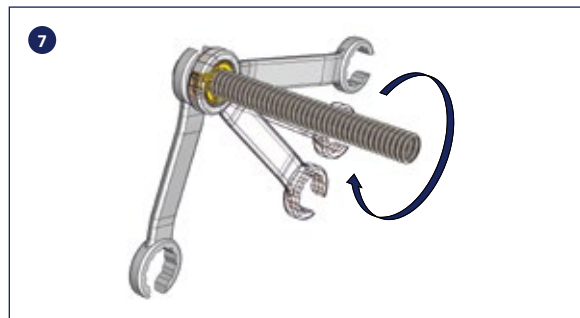

Do not disassemble the fitting: should something happen accidentally, the foot of the internal ring rests on the fitting body

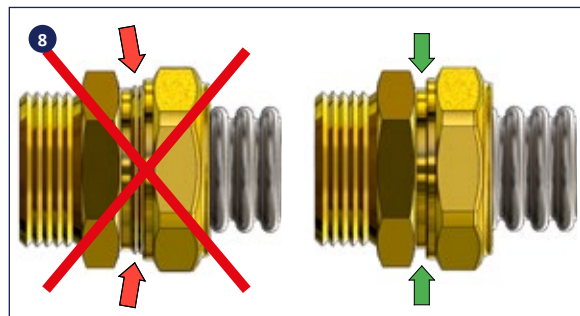



3200X
Straight fitting male

Code	Type	Price €	Unit/Box
071 0057	DN16 x 1/2" M		4/40
071 0058	DN16 x 3/4" M		4/40
071 0059	DN16 x 1" M		4/40
071 0060	DN20 x 3/4" M		4/40
071 0061	DN20 x 1" M		4/40
071 0062	DN25 x 1" M		4/40
071 0063	DN25 x 1 1/4" M		4/40



3202X
Straight fitting female

Code	Type	Price €	Unit/Box
071 0071	DN16 x 1/2" F		4/40
071 0072	DN16 x 3/4" F		4/40
071 0073	DN16 x 1" F		4/40
071 0074	DN20 x 3/4" F		4/40
071 0075	DN20 x 1" F		4/40
071 0096	DN25 x 3/4" F		4/40
071 0076	DN25 x 1" F		4/40



3201X
Double straight fitting

Code	Type	Price €	Unit/Box
071 0064	DN16 x DN16		4/40
071 0065	DN20 x DN20		4/40
071 0066	DN25 x DN25		4/40



3201KB
Double straight union stainless steel/copper

Code	Type	Price €	Unit/Box
071 0067	DN16 x 15 (Cu)		4/40
071 0068	DN16 x 22/18 (Cu)		4/40
071 0069	DN20 x 22/18 (Cu)		4/40
071 0070	DN25 x 22/18 (Cu)		4/40

Supplied with reducer bush



3211X
Straight union stainless steel pipe/cylindrical tube

Code	Type	Price €	Unit/Box
071 0097	DN16 x Ø 18		4/40
071 0077	DN16 x Ø 22		4/40
071 0098	DN20 x Ø 18		4/40
071 0081	DN20 x Ø 22		4/40
071 0100	DN25 x Ø 18		4/40
071 0101	DN25 x Ø 22		4/40



3204X
Elbow fitting male

Code	Type	Price €	Unit/Box
071 0035	DN16 x 1/2" M		5/75



3205X
Elbow fitting female

Code	Type	Price €	Unit/Box
071 0148	DN16 x 1/2" F		5/75
071 0033	DN16 x 3/4" F		5/75



3203KB
Double elbow fitting stainless steel/copper

Code	Type	Price €	Unit/Box
071 0032	DN16 x 22 (Cu)		5/75

COMPATIBILITY TABLE CORRUGATED STAINLESS STEEL PIPE

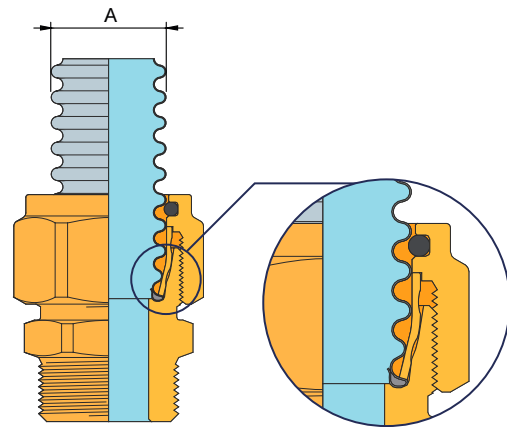

RECOMMENDED PIPE SIZE

DN*	A
16	21.4 ± 0.2
20	26.4 ± 0.2
25	31.7 ± 0.25

*For different diameters please contact our Technical Department

INSTALLATION GUIDE

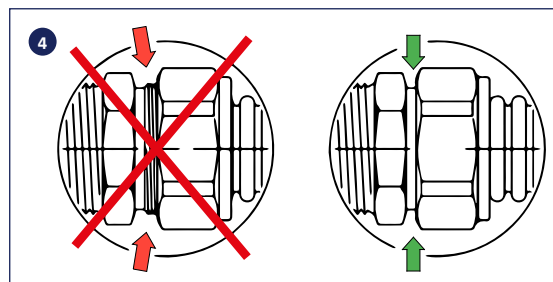
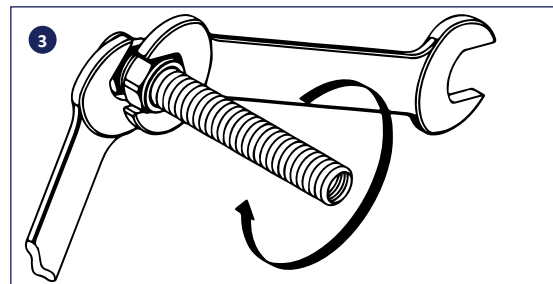
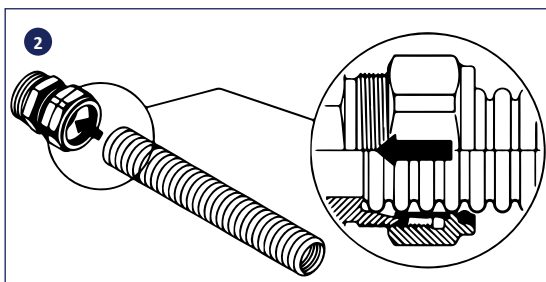
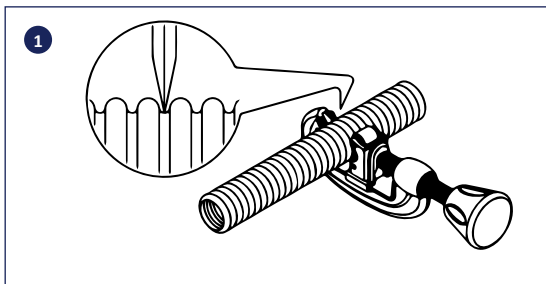

CONNECTION KIT FOR CORRUGATED STAINLESS STEEL PIPE ON FITTINGS WITH MALE THREAD FLAT SEAT

DESCRIPTION

Connection kits art. 1552SET and 8930SET mean quick and easy connection of corrugated steel pipe on fittings with male thread flat seat. See range of compatible fittings (tagged  FLAT SEAT) listed in the following pages.

Fittings for copper pipe series 1100FD, when employing the relevant kit, mean direct connection of copper pipe/corrugated stainless steel pipe, ensuring maximum versatility and flexibility of installation.

INSTRUCTIONS FOR FLARING PIPE

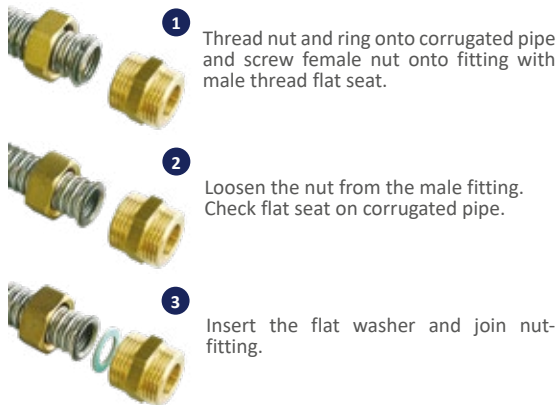

COMPATIBILITY FOR PIPE-FITTING COUPLING

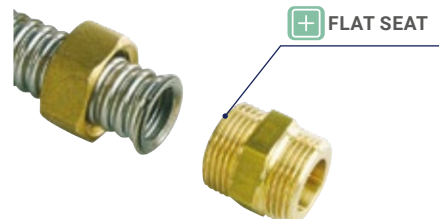

Corrugated steel pipe	Fitting sizes
DN12	1/2"
DN16	3/4"
DN20	1"
DN25	1"1/4



1552SET

Corrugated steel pipe connection set, comprising: 4 nuts, 4 flat washers, 4 rings for tightening nut on corrugated pipe, 2 male nipples

Code	Type	Thread	Price €	Unit/Box
071 0128	DN12	1/2"		1/50
071 0001	DN16	3/4"		1/50
071 0003	DN20	1"		1/25
071 0005	DN25	1" 1/4		1/20



8930IM

Tightening nut for corrugated steel pipe

Code	Type	Price €	Unit/Box
071 0109	1/2"		10/500
071 0007	3/4"		10/300
071 0012	1"		10/200
071 0014	1" 1/4		10/100



8930SET

Corrugated steel pipe installation set, comprising: 4 nuts, 4 nut tighteners

Code	Type	Thread	Price €	Unit/Box
071 0126	DN12	1/2"		1/150
071 0002	DN16	3/4"		1/150
071 0004	DN20	1"		1/100
071 0011	DN25	1" 1/4		1/50



9341SET

Flat washer and ring set for corrugated steel pipes

Code	Type	Price €	Unit/Box
071 0108	DN12		10/500
071 0008	DN16		10/500
071 0009	DN20		10/500
071 0013	DN25		10/500



1100FD

Straight fitting, nut and olive for copper pipe, male connecting thread with flat seat for corrugated steel pipe and flat washer

+ FLAT SEAT

Code	Type	Price €	Unit/Box
471 0023	15 x 1/2"		10/100
471 0010	15 x 3/4"		5/100
471 0048	16 x 1/2"		10/100
471 0026	18 x 1/2"		10/100
471 0009	18 x 3/4"		5/100
471 0065	18 x 1"		5/100
471 0066	22 x 1/2"		5/100
471 0001	22 x 3/4"		5/100
471 0007	22 x 1"		5/75
471 0042	28 x 1" 1/4		1/50



1102FD

Straight fitting, nut and olive for copper pipe, female connecting thread with flat seat

Code	Type	Price €	Unit/Box
471 0054	18 x 1/2"		10/100
471 0044	22 x 1/2"		5/100
471 0062	22 x 3/4"		5/100
471 0055	22 x 1"		5/50



1001 1101

Straight union for connecting copper pipe

Code	Type	Price €	Unit/Box
100 0004	15 x 15		10/100
110 0116	16 x 16		10/100
110 0005	18 x 18		10/100
100 0001	22 x 22		5/75
100 0032	28 x 28		5/50



1552FD

Nipple male thread with flat seat for corrugated steel pipe and flat washer

+ FLAT SEAT

Code	Type	Price €	Unit/Box
471 0052	3/8" x 3/8"		25/100
471 0030	1/2" x 1/2"		10/100
471 0003	3/4" x 3/4"		10/100
471 0017	1" x 1"		5/100
471 0085	1"1/4 x 1"1/4		5/50
471 0086	1"1/2 x 1"1/2		2/30
471 0019	3/4" x 1/2"		10/100
471 0005	1" x 3/4"		5/100
471 0035	1" 1/4 x 1"		5/50
471 0039	1"1/2 x 1"1/4		5/50
471 0056	2" x 1"1/2		2/30



1552FDR

Straight union male/male with plain ends and o-ring

+ FLAT SEAT

Code	Type	Price €	Unit/Box
471 0004	3/4" x 3/4"		10/100
471 0046	1" x 3/4"		5/100



1551FD

Straight male/female with flat seat for corrugated steel pipe with flat washer

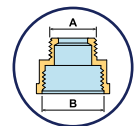

+ FLAT SEAT

Code	Type A B	Price €	Unit/Box
471 0078	3/4" - 1"		10/100





1581FD
Reducer male/female with flat seat

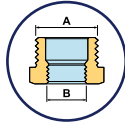

+ FLAT SEAT

Code	Type		Price €	Unit/Box
	A	B		
471 0050	1/2"	3/8"		25/100
471 0022	3/4"	1/2"		10/100
471 0079	1"	1/2"		10/100
471 0012	1"	3/4"		10/100
471 0038	1"	1/4 x 1"		5/50
471 0043	1 1/2"	1" 1/4		5/50
471 0072	2"	1" 1/2		2/40



1553FD
Straight fitting copper transition pipe /corrugated steel pipe

+ FLAT SEAT

Code	Type	Price €	Unit/Box
471 0057	Ø 15 - 3/4"		5/100
471 0016	Ø 22 - 3/4"		5/100
471 0036	Ø 22 - 1"		5/100



1104FD
Bend fitting, nut and olive for copper pipe, male connecting thread with flat seat for corrugated steel pipe and flat washer

+ FLAT SEAT

Code	Type	Price €	Unit/Box
471 0021	15 x 3/4"		5/75
471 0059	16 x 3/4"		5/75
471 0006	18 x 3/4"		5/75
471 0002	22 x 3/4"		5/75
471 0032	22 x 1"		5/50



**1005
1105**
Bend fitting, nut and olive for copper pipe, female thread

Code	Type	Price €	Unit/Box
100 0016	15 x 1/2"		10/100
100 0067	15 x 3/4"		5/75
110 0138	16 x 1/2"		10/100
110 0018	18 x 3/4"		5/75
100 0017	22 x 3/4"		5/75
100 0053	22 x 1"		5/50



**1003
1103**
Elbow fitting for connecting copper pipe

Code	Type	Price €	Unit/Box
100 0002	15 x 15		10/100
110 0144	16 x 16		10/100
110 0003	18 x 18		10/100
100 0054	22 x 15		5/100
110 0056	22 x 18		5/75
100 0003	22 x 22		5/75
100 0148	28 x 22		5/50
100 0015	28 x 28		5/25



1133
Double elbow fitting copper pipe/PEX pipe

Code	Type	Price €	Unit/Box
471 0103	18 (Cu)/18 x 2.5 (PEX)		5/100
471 0067	22 (Cu)/18 x 2.0 (PEX)		5/100
471 0027	22 (Cu)/18 x 2.5 (PEX)		5/100
471 0008	22 (Cu)/22 x 3.0 (PEX)		5/100



1564FD
Male elbow fitting with loose nut and flat washer

+ FLAT SEAT

Code	Type	Price €	Unit/Box
150 0520	3/4" x 3/4"		5/50



1039
1139
Tee fitting lateral female

Code	Type	Price €	Unit/Box
100 0062	15 x 15 x 1/2"		10/100
110 0115	18 x 18 x 1/2"		5/70
100 0022	22 x 22 x 1/2"		5/60



1007
1107
T-fitting for copper pipe

Code	Type	Price €	Unit/Box
	1 2 3		
100 0005	15 x 15 x 15		10/100
100 0133	15 x 22 x 15		5/50
110 0166	16 x 16 x 16		10/80
110 0032	18 x 18 x 18		5/50
100 0086	22 x 15 x 15		5/50
100 0020	22 x 15 x 22		5/50
100 0056	22 x 22 x 15		5/50
100 0013	22 x 22 x 22		5/50
100 0212	22 x 28 x 22		5/25
100 0108	28 x 15 x 28		5/25
100 0174	28 x 22 x 22		5/25
100 0103	28 x 22 x 28		5/25
100 0189	28 x 28 x 15		5/25
100 0183	28 x 28 x 22		5/25
100 0060	28 x 28 x 28		5/25



1138
Tee fitting copper pipe/PEX pipe/copper pipe

Code	Type	Price €	Unit/Box
471 0037	22 (Cu)/18 x 2.5 (PEX)/22(Cu)		5/50
471 0025	22 (Cu)/22 x 3.0 (Pex)/22(Cu)		5/50



1572FD
Tee fitting male connecting thread with flat seat for corrugated steel pipe and flat washer

+ FLAT SEAT

Code	Type	Price €	Unit/Box
	1 2 3		
471 0020	1/2" x 1/2" x 1/2"		10/100
471 0040	3/4" x 1/2" x 1/2"		5/75
471 0041	3/4" x 1/2" x 3/4"		5/75
471 0060	3/4" x 3/4" x 1/2"		5/75
471 0011	3/4" x 3/4" x 3/4"		5/75
471 0049	1" x 3/4" x 1"		5/50
471 0084	1" x 1" x 1"		5/50





1878
Male end cap

Code	Type	Price €	Unit/Box
150 0273	3/8"		25/200
150 0040	1/2"		25/300
150 0019	3/4"		10/150
150 0077	1"		10/100
150 0222	1" 1/4		5/100
150 0865	1" 1/2		5/50
150 0866	2"		2/40



1035
1135
End cap for copper pipe

Code	Type	Price €	Unit/Box
100 0028	15		10/350
110 0027	18		10/220
100 0012	22		5/150
100 0098	28		5/100



1116
Stiffener for copper pipe

Code	Type	Price €	Unit/Box
110 0014	15 x 1.0		50/1300
110 0013	18 x 1.0		100/800
110 0006	22 x 1.0		50/500



1147
Bushing adapter

Code	Type	Price €	Unit/Box
113 0062	15 x 10		25/900
113 0026	15 x 12		25/900
113 0079	18 x 12		25/750
110 0243	18 x 14		25/750
113 0018	18 x 15		25/750
110 0025	18 x 16		25/750
113 0083	22 x 12		25/500
113 0028	22 x 15		25/500
113 0022	22 x 18		25/500
113 0152	28 x 15		25/300
113 0067	28 x 22		10/300



1014
1114
Nut for compression fitting for copper pipe

Code	Type	Price €	Unit/Box
100 0034	15		50/700
110 0055	18		50/600
100 0035	22		25/400
100 0055	28		25/250



1015
1115
Olive for copper pipe compression fitting

Code	Type	Price €	Unit/Box
100 0026	15		50/2000
110 0077	18		50/2000
100 0039	22		50/1200
100 0097	28		50/800



1039S

Tee union with probe holder well (probe Ø6 mm), nut and olive for copper pipe

Code	Type	Probe length	Price €	Unit/Box
471 0064	15 x 15	123 mm		2/10
471 0034	18 x 18	123 mm		2/10
471 0073	18 x 18	164 mm		2/10
471 0024	22 x 22	123 mm		2/10



1113KB

Cross fitting with nut and olive for copper pipe, COBRASUN quick-coupling with probe holder well (probe Ø6 mm) and manual air vent valve.

Code	Type	Probe length	Price €	Unit/Box
471 0097	22 x DN16	123 mm		2/10



1040S

Tee union with probe holder well (probe Ø6 mm) male/male

Code	Type	Probe length	Price €	Unit/Box
471 0095	1" x 1"	123 mm		2/10
471 0080	1" x 1"	164 mm		2/10



1040T

Tee union with male/male plug

Code	Type	Price €	Unit/Box
471 0081	1" x 1"		5/50



1039J

Tee union with nut and olive for copper pipe and manual air vent valve

Code	Type	Price €	Unit/Box
471 0063	15 x 15		10/100
471 0047	18 x 18		5/50
471 0013	22 x 22		5/50





1119FD

Cross fitting with male flat seat connecting threads for corrugated steel pipe and flat washer

+ FLAT SEAT

Code	Type	Price €	Unit/Box
471 0045	3/4" x 3/4"		5/50



1117FD

Cross fitting with nut and olive for copper pipe, male flat seat connecting thread for corrugated steel pipe and flat washer

+ FLAT SEAT

Code	Type	Price €	Unit/Box
471 0033	18 x 3/4"		5/50
471 0014	22 x 3/4"		5/50



1118

Cross fitting with nut and olive for copper pipe

Code	Type	Price €	Unit/Box
471 0053	18 x 18		5/50
471 0029	22 x 22		5/50



9561T

Probe well (Ø6 mm) 1/2" fitting with copper ring included

Code	Type	Price €	Unit/Box
472 0002	123 mm		5/15
472 0005	164 mm		5/15



3353G

Air vent valve with copper gasket

Code	Type	Price €	Unit/Box
472 0003	1/2"		10/500



1900KITSUN

Automatic air vent valve with ball valve Maximum temperature 180°C

Code	Type	Price €	Unit/Box
472 0004	1/2"		2/20

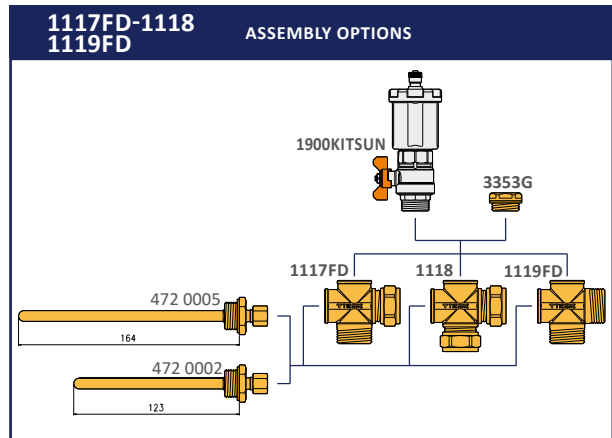



0700X

Pair of insulated corrugated stainless pipes with electrical cable for connecting to electronically-controlled temperature probe

Code	Type	Price €/m	Unit/Box (m)
070 0002	DN16		15/15
070 0001	DN16		20/20
070 0004	DN16		25/25
070 0005	DN20		15/15
070 0003	DN20		20/20
070 0007	DN20		25/25
070 0006	DN25		20/20



0720X

Corrugated pipe in stainless steel

Code	Type	Prezzo €/m	Unit/Box (m)
070 0017	DN12 (sp. 0.15)		100/1000
070 0013	DN16 (sp. 0.18)		100/1000
070 0014	DN20 (sp. 0.18)		100/1000
070 0015	DN25 (sp. 0.22)		50/500
070 0018	DN32 (sp. 0.22)		25/375

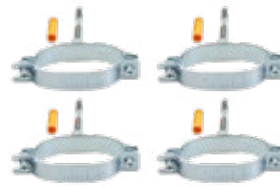

0705COL

4 oval collar set for wall mounting pair of insulated corrugated steel pipes

Code	Type	Price €	Unit/Box
071 0006	DN16		1/20
071 0010	DN20		1/20
071 0015	DN25		1/20



10 DIRECT METERING UTILITY MODULES

10A	Direct metering - introduction	178
<hr/>		
10B	SHORTY metering system	
<hr/>		
	SHORTY metering system	180
<hr/>		
	SHORTY DYNAMIC metering system	186
<hr/>		
10C	BASIC metering system	
<hr/>		
	BASIC metering system	192
<hr/>		
	BASIC HT metering system	195
<hr/>		
10D	MULTI-MODUL metering system	199
<hr/>		
10E	VARIO metering system	199
<hr/>		
10F	FLOOR metering system	
<hr/>		
	FLOOR DN20 metering system	210
<hr/>		
	FLOOR DN25 - DN32 metering system	213
<hr/>		
10G	HEAT metering system	218
<hr/>		
10H	HEAT EVO metering system	220
<hr/>		
10I	TECHNO SEP metering system	225
<hr/>		

In recent years, the ever greater focus on energy saving and the reduction of polluting emissions has steered the building industry toward the installation of centralized systems and heat metering systems able to determine the calories/frigorios used for ambient climate control in each unit of housing.

The aim is to make each individual user completely autonomous in managing their own energy consumption.

Therefore, each dwelling may manage its own system and accordingly its own energy consumption, which could not be done in the past since the expenditure was simply divided according to the property's thousandths shares.

The adoption of centralized systems with metering:

- Guarantees the ability to manage the heating requirements of each individual unit independently and then decide independently according to one's own hourly requirements;
- Saves on individual boiler maintenance costs (rather than one boiler for every apartment, only one boiler for all dwelling units);
- Frees up space within the home as accommodating boiler housing is not required;
- Guarantees greater safety to each individual dwelling unit by removing the presence of the boiler (additionally the presence of a centralized boiler ensures that periodic maintenance checks are carried out);
- Guarantees a general reduction in consumption and an accompanying reduction in harmful emissions, safeguarding the environment. Autonomous energy consumption management in a centralized system has been shown to lead to an overall energy saving for the building of up to 25%.

In order to benefit from the advantages linked to centralized management systems, along with those stemming from the autonomous management of each individual property unit's heating requirements, it is necessary to introduce systems for the individual metering of consumption.

Direct heat metering is based on the measurement of the difference in enthalpy of the thermal carrier fluid between the inlet and outlet of the user circuit.

Direct metering is easily used in systems featuring a single power supply circuit for each dwelling unit. It is therefore particularly suitable for:

- new buildings with horizontal distribution systems;
- conversion of existing self-contained systems into new systems with centralized heat production.



10A THE TIEMME DIRECT METERING SYSTEM

Tiemme metering modules are right at home within buildings with centralized systems and in systems with district heating, allowing the completely autonomous management by each individual unit as prescribed by the regulations in force.

TIEMME has pre-assembled modules available, suitable for every type of system, alongside additional ability to supply «bespoke» modules designed to meet even the most exceptional of requirements.

Particular attention has been paid to the compactness of the solutions with multi-utility modules with reduced dimensions, and to the means of carrying out correct system balancing in the inclusion of static or dynamic balancing valves.

Tiemme technology is based on the use of meters suitable for the measurement of thermal and/or refrigerating energy taken from each dwelling unit and is compatible with all the most common heating systems (radiators, fan convectors, radiant methods). The calorie/frigory consumption of each individual user is measured directly by the calorimeter installed at the apartment's inlet to the distribution network.

TIEMME offers volumetric or ultrasonic thermal energy meters for energy consumption reading and meters for domestic hot and cold water usage, all of which are MID certified.

Usage data readings can be carried out according to the individual requirements, via a "local reading" system, or systems with remote M-Bus or wireless reading.

M-Bus or wireless meters transmit usage data to data collection units, making the data accessible to those taking care of the calculation necessary for correct billing.

According to the UNI EN 1434 standard, direct metering becomes the mandatory system wherever the technical ability exists to directly intercept the thermal carrier fluid while simultaneously measuring the flow rate of the fluid and the inlet and outlet temperature, in order to determine the value of the power given out by the heating bodies.

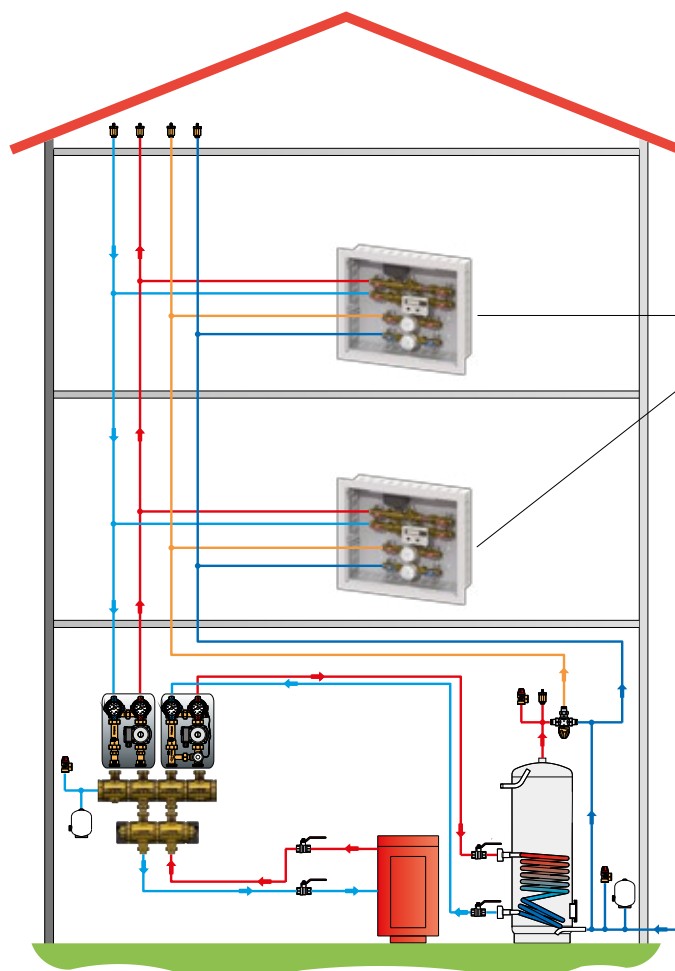

SHORTY SYSTEM



Schematic representation:

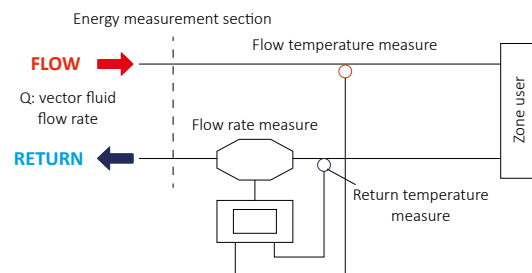

10_B SHORTY METERING SYSTEM

INTRODUCTION

Metering module for heating/cooling and domestic water circuits, featuring **reduced dimensions**. Ideal system solution where space is limited and for flow rates up to 2.5 m³/h.

Available in different versions and configurations to meet various installation needs:

- Available with 3 domestic water lines.
- Available on request; module housed in flush-mounted casing or version with metal clamps for mounting the module to the wall.
- Multi-utility housing available: Serving 2 or 3 adjacent utilities, thus creating a single point of access to metering devices to a floor.

The core of Shorty modules is the hydraulic unit that may be installed within the housing, which can be ordered separately according to usage reading requirements.

The multi-function unit means calorie and frigory consumption can be read in local mode via the reader LCD display, as well as in remote M-Bus or wireless mode.

Also available in the volumetric or ultrasonic heat meter versions to meet the most demanding requirements, ultrasonic flow rate measurement means greater precision in consumption counting and high wear resistance because it does not have moving parts.



- | | |
|--|---------------------------------|
| 1. Shut-off valves | 7. Compact thermal energy meter |
| 2. Motorized 3-way zone valve | 8. Domestic hot water meter |
| 3. Control bypass | 9. Domestic cold water meter |
| 4. Heating-cooling system flow rate control valve | |
| 5. Impurities-collecting filter with delivery probe holder | |
| 6. Metal housing complete with cover and supports | |



10_B SHORTY METERING SYSTEM

INSTALLATION COMPONENTS

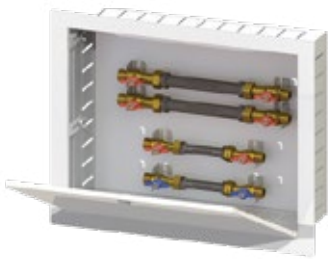

6502C01

Pre-installation metal housing for "SHORTY STATIC" system. Setup stubs included.

DESCRIPTION

- Galvanized steel housing complete with painted frame and cover white RAL 9010
- Dimensions (WxHxD) 500 x 420 x 120 ÷ 170 mm
- Shut-off ball valves for heating/cooling circuit with 3/4" M and 1" F fittings with idle nut
- Shut-off ball valves for domestic water circuits with 3/4" M and 3/4" F fittings with idle nut (with or without built-in non-return valve)
- "Pre-installation" stubs for system testing and/or wash and subsequent installation of domestic water meters 110 mm interaxle DN15 (3/4")/SHORTY metering module
- Galvanized steel templates for fixing the valves shut-off to the bottom of the housing

Code	Dimensions (mm)	Price €	Unit/Box
650 0279	500 x 420 x 120 ÷ 170		1/1



6502C01-3C

Pre-installation metal housing for "STATIC SHORTY AND THREE DOMESTIC WATER LINES" system. Pre-set stubs included.

DESCRIPTION

- Galvanized steel housing complete with painted frame and cover white RAL 9010
- Dimensions (WxHxD) 500 x 500 x 120 ÷ 170 mm
- Shut-off ball valves for heating/cooling circuit with connections 3/4" M and 1" F with idle nut
- Shut-off ball valves for domestic water circuits with 3/4" M and 3/4" F fittings with idle nut (with or without built-in non-return valve)
- "Pre-installation" stubs for system testing and/or wash and subsequent installation of domestic water meters 110 mm interaxle DN15 (3/4")/SHORTY metering module
- Galvanized steel templates for fixing the valves shut-off to the bottom of the housing

3 domestic water lines

Code	Dimensions (mm)	Price €	Unit/Box
650 0618	500 x 500 x 120 ÷ 170		1/1

6502C01

DIMENSIONAL DIAGRAM FUNCTIONAL DIAGRAM

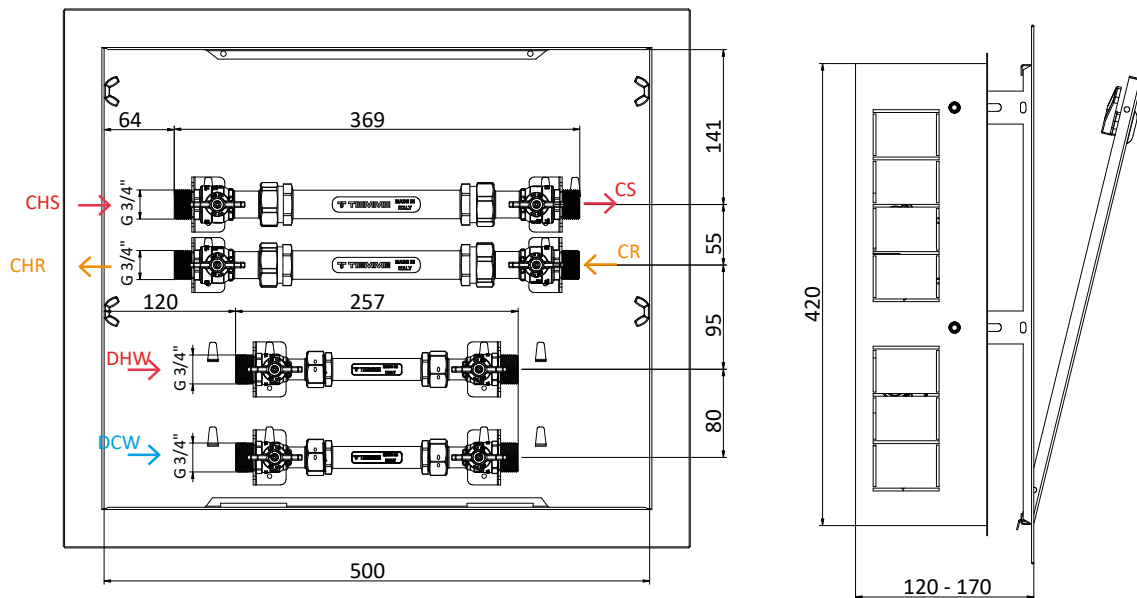

Abbreviation	Description	Abbreviation	Description
CHS	Central heating supply	CR	Consumer return
CHR	Central heating return	DHW	Domestic hot water
CS	Consumer supply	DCW	Domestic cold water



6502C01DUO

Pre-installation metal housing for "SHORTY DUO STATIC" system. Pre-set stubs included.

DESCRIPTION

- Galvanized steel housing complete with painted frame and cover white RAL 9010
 - Dimensions (WxHxD) 500 x 800 x 120 ÷ 170 mm
- Shut-off ball valves for heating/cooling circuit with connections 3/4" M and 1" F with idle nut
- Shut-off ball valves for domestic water circuits with 3/4" M and 3/4" F fittings with idle nut (with or without built-in non-return valve)
- "Pre-installation" stubs for system testing and/or wash and subsequent installation of domestic water meters 110 mm interaxle DN15 (3/4")/SHORTY metering module
- Galvanized steel templates for fixing the valves shut-off to the bottom of the housing

Compact solution for 2 utilities

Code	Dimensions (mm)	Price €	Unit/Box
650 0286	500 x 800 x 120 ÷ 170		1/1



6502C01DUO-3C

Pre-installation metal housing for "SHORTY DUO STATIC AND THREE DOMESTIC WATER LINES" system. Pre-set stubs included.

DESCRIPTION

- Galvanized steel housing complete with painted frame and cover in white RAL 9010
 - Dimensions (WxHxD) 500 x 980 x 120 ÷ 170 mm
- Shut-off ball valves for heating/cooling circuit with connections 3/4" M and 1" F with idle nut
- Shut-off ball valves for domestic water circuits with 3/4" M and 3/4" F fittings with idle nut (with or without built-in non-return valve)
- "Pre-installation" stubs for system testing and/or wash and subsequent installation of domestic water meters 110 mm interaxle DN15 (3/4")/SHORTY metering module
- Galvanized steel templates for fixing the valves shut-off to the bottom of the housing

3 domestic water lines

Compact solution for 2 utilities

Code	Dimensions (mm)	Price €	Unit/Box
650 0619	500 x 980 x 120 ÷ 170		1/1



6502C01TRIO

Pre-installation metal housing for "SHORTY TRIO STATIC" system. Pre-set stubs included.

DESCRIPTION

- Galvanized steel housing complete with painted frame and cover in white RAL 9010
 - Dimensions (WxHxD) 500 x 1200 x 120 ÷ 170 mm
- Shut-off ball valves for heating/cooling circuit with connections 3/4" M and 1" F with idle nut
- Shut-off ball valves for domestic water circuits with 3/4" M and 3/4" F fittings with idle nut (with or without built-in non-return valve)
- "Pre-installation" stubs for system testing and/or wash and subsequent installation of domestic water meters 110 mm interaxle DN15 (3/4")/SHORTY metering module
- Galvanized steel templates for fixing the valves shut-off to the bottom of the housing

Compact solution for 3 utilities

Code	Dimensions (mm)	Price €	Unit/Box
650 0287	500 x 1200 x 120 ÷ 170		1/1



6502C01TRIO-3C

Pre-installation metal housing for "SHORTY TRIO STATIC AND DOMESTIC WATER LINES" system. Predisposition stubs included.

DESCRIPTION

- Galvanized steel housing complete with painted frame and cover in white RAL 9010
 - Dimensions (WxHxD) 500 x 1450 x 120 ÷ 170 mm
- Shut-off ball valves for heating/cooling circuit with connections 3/4" M and 1" F with idle nut
- Shut-off ball valves for domestic water circuits with 3/4" M and 3/4" F fittings with idle nut (with or without built-in non-return valve)
- "Pre-installation" stubs for system testing and/or wash and subsequent installation of domestic water meters 110 mm interaxle DN15 (3/4")/SHORTY metering module
- Galvanized steel templates for fixing the valves shut-off to the bottom of the housing

3 domestic water lines

Compact solution for 3 utilities

Code	Dimensions (mm)	Price €	Unit/Box
650 0620	500 x 1450 x 120 ÷ 170		1/1





6502KP
"SHORTY" System wall mount pre-installation kit. Pre-set stubs included.

DESCRIPTION

- Shut-off ball valves for heating/cooling circuit with 3/4" M and 1" F fittings with idle nut
- Shut-off ball valves for domestic water circuits with 3/4" M and 3/4" F fittings with idle nut (with or without built-in non-return valve)
- "Pre-installation" stubs for system testing and/or wash and subsequent installation of domestic water meters 110 mm interaxle DN15 (3/4")/SHORTY metering module
- Galvanized steel templates for fixing the valves shut-off to the bottom of the housing

 For possible third domestic water line metering according to art. 6502LS



Code	Dimensions (mm)	Price €	Unit/Box
650 0581	-		1/1

6502LS
Hot water/cold water domestic water lines without meter.



DESCRIPTION

- Shut-off ball valves with 3/4" M E ports 3/4" F with idle nut (with or without integrated non-return valve)
- "Pre-installation" stub for testing and/or flushing system and subsequent installation of the domestic water meter 110 mm interaxle DN15 (3/4")
- Flat washers
- Galvanized steel supports for fixing shut-off valves to the bottom of the housing

Code	Type	Price €	Unit/Box
 red handle			
650 0601	DN15 domestic hot water		1/1
 blue handle			
650 0602	DN15 domestic cold water		1/1



6502G03
"SHORTY" compact heat meter metering module, 3-way motorized zone valve for heating/cooling systems.



DESCRIPTION

- 3-way zone valve with motorized bypass (230 VAC or 24 VAC power supply)
- Differential bypass tee
- Supply temperature probe holder fitting with M10x1 port
- Impurity-removing filter
- Static balance valve
- Compact calorie/frigory meter 130 mm DN20 (1") Qp = 2.5 m³/h complete with electronic unit and 2x Ø5 mm probes

Code	Type	Power supply	Price €	Unit/Box
650 0280	Local reading	230 VAC		1/1
650 0399	Local reading	24 VAC		1/1
650 0281	M-Bus reading	230 VAC		1/1
650 0400	M-Bus reading	24 VAC		1/1
650 0545	Wireless reading	230 VAC		1/1
650 0586	Wireless reading	24 VAC		1/1



6502G03U
"SHORTY" metering module consisting of compact ULTRASONIC calorie counter, 3-way motorized zone valve for heating/cooling systems.



DESCRIPTION

- 3-way zone valve with motorized bypass (230 VAC or 24 VAC power supply)
- Differential bypass tee
- Supply temperature probe holder fitting with M10x1 port
- Impurity-removing filter
- Static balancing valve
- Compact ultrasonic calorie/frigory meter 130 mm (1") interaxle DN20 Qp = 2.5 m³/h with electronic unit and 2x Ø5 mm probes

Code	Type	Power supply	Price €	Unit/Box
650 0582	Local reading	230 VAC		1/1
650 0583	Local reading	24 VAC		1/1
650 0585	M-Bus reading	230 VAC		1/1
650 0584	M-Bus reading	24 VAC		1/1
650 0587	Wireless reading	230 VAC		1/1
650 0588	Wireless reading	24 VAC		1/1



6561C

Single jet meter for hot or cold water with local or remote M-Bus reading.



TECHNICAL SPECIFICATIONS

- Brass casing with direct reading on 8 numbered rollers: 5 (black) for cubic meters – 3 (red) for sub-multiples
- Maximum operating temperature:
 - 50 °C (domestic cold water model)
 - 90 °C (domestic hot water model)
- Nominal pressure (PN) 16 bar
- Certified according to Directive 2014/32/EU (Annex MI-001)

i For installation on horizontal or vertical pipes

i Prearranged for remote reading if combined with art. 6561E

Code	Size	Type	Price €	Unit/Box
651 0024	DN15 (3/4")* Q3 = 2.5 m ³ /h	domestic cold water		1/12
651 0026	DN15 (3/4")* Q3 = 2.5 m ³ /h	domestic hot water		1/12

* Size of thread body



6561E

Pulse launcher cable. 1/10 pulse/liter.



TECHNICAL SPECIFICATIONS

- Cable length: 1 m

Code	Type	Price €	Unit/Box
651 0085	For 6561C		1/10



6561CR 6561HR

Single jet meter for hot or cold water with local or wireless remote reading



TECHNICAL SPECIFICATIONS

- Brass casing with direct reading on 8 numbered rollers: 5 (black) for cubic meters – 3 (red) for sub-multiples
- Maximum operating temperature:
 - 50 °C (domestic cold water model)
 - 90 °C (domestic hot water model)
- Nominal pressure (PN) 16 bar
- Approved in accordance with Directive 2014/32/EU (Annex MI-001)

i For installation on horizontal or vertical pipes

i Prearranged for wireless data transmission when combined with art. 6561MR

Code	Size	Type	Price €	Unit/Box
651 0484	DN15 (3/4")* Q3 = 2.5 m ³ /h	domestic cold water		1/12
651 0514	DN15 (3/4")* Q3 = 2.5 m ³ /h	domestic hot water		1/12

* Size of thread body



6561MR

Compact radio module with integrated 868 MHz WIRELESS M-Bus inductive wireless sensor.



TECHNICAL SPECIFICATIONS

- Power supply: lithium battery, service life 11+1 years
- Protection rating: IP67

Code	Type	Price €	Unit/Box
651 0486	For 6561CR - 6561HR		1/40





6502K

Fixing kit components for "SHORTY" and "SHORTY DYNAMIC" metering modules

DESCRIPTION

- Shut-off ball valves for heating/cooling circuit with 3/4" M and 1" F fittings with idle nut
- Shut-off ball valves for domestic hot/cold water line with 3/4" M and 3/4" F fittings with idle nut (with or without built-in non-return valve)
- Flat washers
- Galvanized steel supports for fixing shut-off valves to the bottom of the housing

Code	Type	Price €	Unit/Box
650 0301	SHORTY/SHORTY DYNAMIC		1/4



6502T

Temporary stubs for "SHORTY" pre-installation housing.

TECHNICAL SPECIFICATIONS

- Interaxle 194 mm (for SHORTY metering module)
- Interaxle 110 mm (for domestic water meters)

i To be used for flushing and/or hydraulic testing of the system

Code	Type	Price €	Unit/Box
651 0284	SHORTY		1/10



6502I

Thermoformed thermal insulation for "SHORTY" metering modules

TECHNICAL SPECIFICATIONS

- Insulation shell material: PEX closed cell foam

Code	Type	Price €	Unit/Box
650 0284	SHORTY		1/1

10_B SHORTY DYNAMIC METERING SYSTEM

INTRODUCTION

Metering module for heating/cooling and domestic water circuits, featuring **reduced proportions**. Ideal system solution where space is limited and for flow rates up to 2.5 m³/h.

Fitted with a dynamic balancing PICV (Pressure Independent Control Valves), the system-side flow rate can be adjusted from a minimum of 529 l/h to a maximum of 1470 l/h. Even in the face of flow variations due to the opening/closing by the individual utilities on the branches of the system, the PICV valve operates by keeping the set flow rate constant, avoiding both hydraulic imbalances and discomfort and energy consumption issues.

Available in different versions and configurations to meet various installation needs:

- Available with 3 domestic water lines.
- Available on request; module housed in flush-mounted casing or version with metal clamps for mounting the module to the wall.
- Multi-utility housing available: Serving 2 or 3 adjacent utilities, thus creating a single, easy point of access to metering devices.

The core of Shorty Dynamic modules is the hydraulic unit that may be installed within the housing, which ordered separately according to usage reading requirements. The multi-function unit means calorie and frigory consumption can be read in local mode via the LCD reader display, as well as in remote M-Bus or wireless mode. Also available in volumetric or ultrasonic heat meter versions to meet the most demanding requirements, ultrasonic -based flow rate measurement means greater precision in consumption counting and increased wear resistance due to lack of moving parts.



- | | |
|--|---|
| 1. Shut-off valves | 7. Metal housing complete with cover and supports |
| 2. Motorized 3-way zone valve | 8. Compact thermal energy meter |
| 3. Control bypass | 9. Domestic hot water meter |
| 4. Heating-cooling system flow rate control valve | 10. Domestic cold water meter |
| 5. Impurity-trapping filter with flow probe holder | |
| 6. Dynamic balancing valve | |



10_B SHORTY DYNAMIC METERING SYSTEM

INSTALLATION COMPONENTS



6502C01DYN

Pre-installation metal housing for "SHORTY DYNAMIC" system. Setup stubs included.

DESCRIPTION

- Galvanized steel housing complete with painted frame and cover in white RAL 9010
 - Dimensions (WxHxD) 500 x 420 x 120 ÷ 170 mm
- Shut-off ball valves for heating/cooling circuit with 3/4" M and 1" F fittings with idle nut
- Shut-off ball valves for domestic water circuits with 3/4" M and 3/4" F fittings with idle nut (with or without built-in non-return valve)
- "Pre-installation" stubs for testing and/or flushing system and subsequent installation of domestic water meters 110 mm interaxle DN15 (3/4")/ SHORTY DYNAMIC metering module
- Galvanized steel templates for fixing shut-off valves to the bottom of the housing

Code	Dimensions (mm)	Price €	Unit/Box
650 0604	500 x 420 x 120 ÷ 170		1/1



6502C01DYN-3C

Pre-installation metal housing for "SHORTY DYNAMIC AND THREE DOMESTIC WATER LINES" system. Setup stubs included.

DESCRIPTION

- Galvanized steel housing complete with painted frame and cover in white RAL 9010
 - Dimensions (WxHxD) 500 x 500 x 120 ÷ 170 mm
- Shut-off ball valves for heating/cooling circuit with 3/4" M and 1" F fittings with idle nut
- Shut-off ball valves for domestic water circuits with 3/4" M and 3/4" F fittings with idle nut (with or without built-in non-return valve)
- "Pre-installation" stubs for testing and/or flushing system and subsequent installation of 110 mm (3/4") interaxle DN15/ SHORTY DYNAMIC metering module
- Galvanized steel templates for fixing the valves shut-off to the bottom of the housing

 3 domestic water lines

Code	Dimensions (mm)	Price €	Unit/Box
650 0621	500 x 500 x 120 ÷ 170		1/1

6502C01DYN

DIMENSIONAL DIAGRAM FUNCTIONAL DIAGRAM

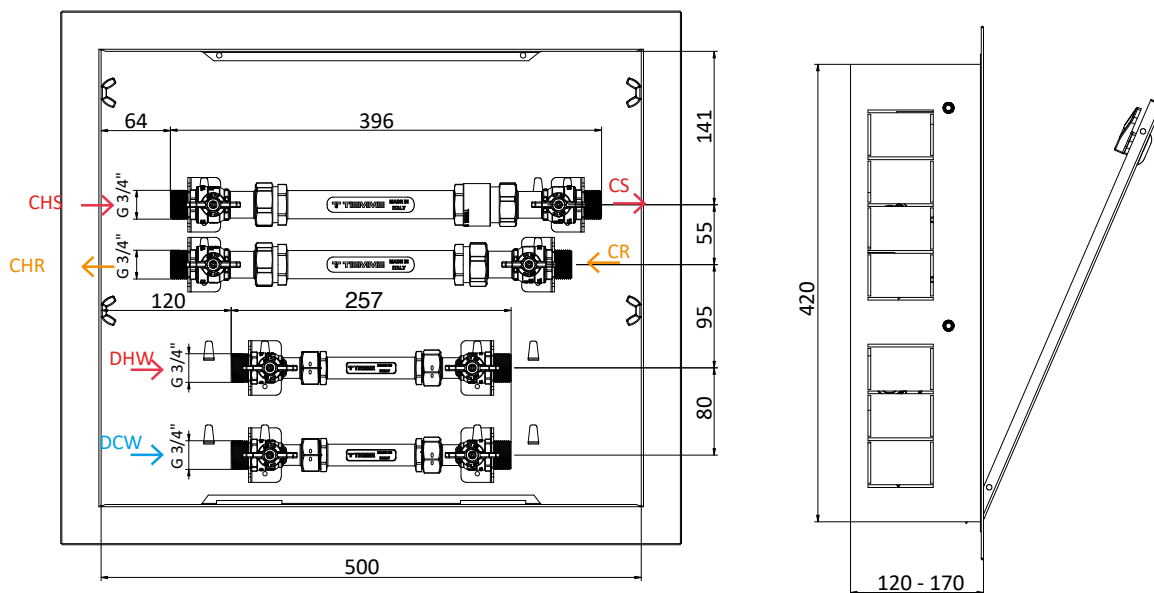

Abbreviation	Description
CHS	Central heating supply
CHR	Central heating return
CS	Consumer supply

Abbreviation	Description
CR	Consumer return
DHW	Domestic hot water
DCW	Domestic cold water

INSTALLATION COMPONENTS



6502C01DUODYN

Pre-installation metal housing for "SHORTY DUO DYNAMIC" system. Setup stubs included.

DESCRIPTION

- Galvanized steel housing complete with painted frame and cover in white RAL 9010
 - Dimensions (WxHxD) 500 x 800 x 120 ÷ 170 mm
- Shut-off ball valves for heating/cooling circuit with 3/4" M and 1" F fittings with idle nut
- Shut-off ball valves for domestic water circuits with 3/4" M and 3/4" F fittings with idle nut (with or without built-in non-return valve)
- "Pre-installation" stubs for testing and/or flushing system and subsequent installation of domestic water meters 110 mm interaxle DN15 (3/4")/ SHORTY DYNAMIC metering module
- Galvanized steel templates for fixing shut-off valves to the bottom of the housing

 Compact solution for 2 utilities

Code	Dimensions (mm)	Price €	Unit/Box
650 0608	500 x 800 x 120 ÷ 170		1/1

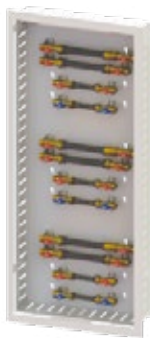

6502C01TRIODYN

Pre-installation metal housing for "SHORTY TRIO DYNAMIC" system. Setup stubs included.

DESCRIPTION

- Galvanized steel housing complete with painted frame and cover in white RAL 9010
 - Dimensions (WxHxD) 500 x 1200 x 120 ÷ 170 mm
- Shut-off ball valves for heating/cooling circuit with 3/4" M and 1" F fittings with idle nut
- Shut-off ball valves for domestic water circuits with 3/4" M and 3/4" F fittings with idle nut (with or without built-in non-return valve)
- "pre-installation" stubs for testing and/or flushing system and subsequent installation of 110 mm interaxle DN15 (3/4")/ SHORTY DYNAMIC metering module
- Galvanized steel templates for fixing the valves shut-off to the bottom of the housing

 Compact solution for 3 utilities

Code	Dimensions (mm)	Price €	Unit/Box
650 0609	500 x 1200 x 120 ÷ 170		1/1



6502C01DUODYN-3C

Pre-installation metal housing for "SHORTY DUO DYNAMIC AND THREE DOMESTIC WATER LINES" system. Setup stubs included.

DESCRIPTION

- Galvanized steel housing complete with painted frame and cover in white RAL 9010
 - Dimensions (WxHxD) 500 x 980 x 120 ÷ 170 mm
- Shut-off ball valves for heating/cooling circuit with 3/4" M and 1" F fittings with idle nut
- Shut-off ball valves for domestic water circuits with 3/4" M and 3/4" F fittings with idle nut (with or without built-in non-return valve)
- "Pre-installation" stubs for testing and/or flushing system and subsequent installation of domestic water meters 110 mm interaxle DN15 (3/4")/ SHORTY DYNAMIC metering module
- Galvanized steel templates for fixing the valves shut-off to the bottom of the housing

 3 domestic water lines

 Compact solution for 2 utilities

Code	Dimensions (mm)	Price €	Unit/Box
650 0622	500 x 980 x 120 ÷ 170		1/1



6502C01TRIODYN-3C

Pre-installation metal housing for "SHORTY TRIO DYNAMIC AND THREE DOMESTIC WATER LINES" system. Setup stubs included.

DESCRIPTION

- Galvanized steel housing complete with painted frame and cover in white RAL 9010
 - Dimensions (WxHxD) 500 x 1450 x 120 ÷ 170 mm
- Shut-off ball valves for heating/cooling circuit with 3/4" M and 1" F fittings with idle nut
- Shut-off ball valves for domestic water circuits with 3/4" M and 3/4" F fittings with idle nut (with or without built-in non-return valve)
- "Pre-installation" stubs for testing and/or flushing system and subsequent installation of domestic water meter 110 mm interaxle DN15 (3/4")/ SHORTY DYNAMIC metering module
- Galvanized steel templates for fixing the valves shut-off to the bottom of the housing

 3 domestic water lines

 Compact solution for 3 utilities

Code	Dimensions (mm)	Price €	Unit/Box
650 0623	500 x 1450 x 120 ÷ 170		1/1



10_B SHORTY DYNAMIC METERING SYSTEM

INSTALLATION COMPONENTS



6502KPDYN
"SHORTY" system wall mounting pre-installation kit. Setup stubs included.

DESCRIPTION

- Shut-off ball valves for heating/cooling circuit with 3/4" M and 1" F fittings with idle nut
- Shut-off ball valves for domestic water circuits with 3/4" M and 3/4" F fittings with idle nut (with or without built-in non-return valve)
- "Pre-installation" stubs for testing and/or flushing system and subsequent installation of domestic water meter 110 mm interaxle DN15 (3/4") / SHORTY DYNAMIC metering module
- Galvanized steel templates for wall mounting shut-off valves

i For possible third domestic water line metering according to art. 6502LS



Code	Dimensions (mm)	Price €	Unit/Box
650 0605	-		1/1

6502LS
Hot /cold domestic water lines without meter.



DESCRIPTION

- Shut-off ball valves with 3/4" M and 3/4" F fittings with idle nut (with or without integrated non-return valve)
- "Pre-installation" stub for testing and/or flushing system and subsequent installation of domestic water meter 110 mm interaxle DN15 (3/4")
- Plain gaskets
- Galvanized steel supports for fixing shut-off valves to the bottom of the housing

Code	Type	Price €	Unit/Box
 red handle			
650 0601	DN15 domestic hot water		1/1
 blue handle			
650 0602	DN15 domestic cold water		1/1



6502G03DYN
"SHORTY DYNAMIC" metering module consisting of compact calorimeter counter, 3-way motorized zone valve for heating/cooling systems, PICV dynamic balancing valve.



DESCRIPTION

- 3-way zone valve with motorized bypass (230 VAC or 24 VAC power supply)
- Differential bypass tee
- Flow temperature probe holder with M10x1 fitting
- Impurity-removing filter
- PICV dynamic balancing valve (529÷1470 l/h adjustment)
- Compact calorimeter/frigory meter 130 mm (1") interaxle DN20 Qp = 2.5 m³/h with electronic unit and 2x Ø5 mm probes

Code	Type	Power supply	Price €	Unit/Box
650 0589	Local reading	230 VAC		1/1
650 0590	Local reading	24 VAC		1/1
650 0591	M-Bus reading	230 VAC		1/1
650 0592	M-Bus reading	24 VAC		1/1
650 0593	Wireless reading	230 VAC		1/1
650 0594	Wireless reading	24 VAC		1/1



6502G03DYNU
Metering module "SHORTY DYNAMIC" consisting of compact **ULTRASONIC calorimeter counter** 3-way motorized zone valve for heating/cooling systems, PICV dynamic balancing valve.



DESCRIPTION

- 3-way zone valve with motorized bypass (230 VAC or 24 VAC power supply)
- Differential bypass tee
- Flow temperature probe holder with M10x1 fitting
- Impurity-removing filter
- PICV dynamic balancing valve (529÷1470 l/h adjustment)
- Compact ultrasonic calorimeter/frigory meter 130 mm (1") interaxle DN20 Qp = 2.5 m³/h with electronic unit and 2x Ø5 mm probes

Code	Type	Power supply	Price €	Unit/Box
650 0595	Local reading	230 VAC		1/1
650 0596	Local reading	24 VAC		1/1
650 0597	M-Bus reading	230 VAC		1/1
650 0598	M-Bus reading	24 VAC		1/1
650 0599	Wireless reading	230 VAC		1/1
650 0600	Wireless reading	24 VAC		1/1



6561C

Single jet meter for hot or cold water with local or remote M-Bus reading.



TECHNICAL SPECIFICATIONS

- Brass casing with direct reading on 8 numbered rollers: 5 (black) for cubic metres – 3 (red) for sub-multiples
- Maximum operating temperature:
 - 50 °C (domestic cold water model)
 - 90 °C (domestic hot water model)
- Nominal pressure (PN) 16 bar
- Certified according to Directive 2014/32/EU (Annex MI-001)

i For installation on horizontal or vertical pipes

i Prearranged for remote reading if combined with art. 6561E

Code	Size	Type	Price €	Unit/Box
651 0024	DN15 (3/4")* Q3 = 2.5 m ³ /h	domestic cold water		1/12
651 0026	DN15 (3/4")* Q3 = 2.5 m ³ /h	domestic hot water		1/12

* Size of thread body



6561E

Pulse emitter cable. 1/10 pulse/liter.



TECHNICAL SPECIFICATIONS

- Cable length: 1 m

Code	Type	Price €	Unit/Box
651 0085	For 6561C		1/10



6561CR 6561HR

Single jet meter for hot or cold water with local or wireless remote reading



TECHNICAL SPECIFICATIONS

- Brass casing with direct reading on 8 numbered rollers: 5 (black) for cubic metres – 3 (red) for sub-multiples
- Maximum operating temperature:
 - 50 °C (domestic cold water model)
 - 90 °C (domestic hot water model)
- Nominal pressure (PN) 16 bar
- Approved in accordance with Directive 2014/32/EU (Annex MI-001)

i For installation on horizontal or vertical pipes

i Configured for wireless data transmission when combined with art. 6561MR

Code	Size	Type	Price €	Unit/Box
651 0484	DN15 (3/4")* Q3 = 2.5 m ³ /h	domestic cold water		1/12
651 0514	DN15 (3/4")* Q3 = 2.5 m ³ /h	domestic hot water		1/12

* Size of thread body



6561MR

Compact radio module with integrated 868 MHz WIRELESS M-Bus inductive wireless sensor.



TECHNICAL SPECIFICATIONS

- Power supply: lithium battery, service life 11+1 years
- Protection rating: IP67

Code	Type	Price €	Unit/Box
651 0486	For 6561CR - 6561HR		1/40





6502K

Fixing kit components for "SHORTY" and "SHORTY DYNAMIC" metering modules

DESCRIPTION

- Shut-off ball valves for heating/cooling circuit with 3/4" M and 1" F fittings with idle nut
- Shut-off ball valves for domestic hot/cold water line with 3/4" M and 3/4" F fittings with idle nut (with or without built-in non-return valve)
- Plain gaskets
- Galvanized steel supports for fixing shut-off valves to the bottom of the housing

Code	Type	Price €	Unit/Box
650 0301	SHORTY/SHORTY DYNAMIC		1/4



6502TDYN

Provisional stubs for "SHORTY DYNAMIC" pre-installation housing.

TECHNICAL SPECIFICATIONS

- Interaxle 194 mm (for SHORTY DYNAMIC metering module)
- Interaxle 110 mm (for domestic water meters)

i To be used for flushing and/or hydraulic testing of system

Code	Type	Price €	Unit/Box
651 0641	SHORTY DYNAMIC		1/10



6502IDYN

Thermoformed thermal insulation for "SHORTY DYNAMIC" metering modules

TECHNICAL SPECIFICATIONS

- Insulating shell material: PEX closed cell foam

Code	Type	Price €	Unit/Box
650 0626	SHORTY DYNAMIC		1/1

10_C BASIC METERING SYSTEM

INTRODUCTION

Metering modules for heating/cooling or domestic water circuits, featuring **extremely compact dimensions**. Equipped with wall brackets.

They are the ideal solution for systems where space is limited and for capacities up to 2.5 m³/h for heating/cooling and up to 4 m³/h for domestic water.

HEATING/ COOLING

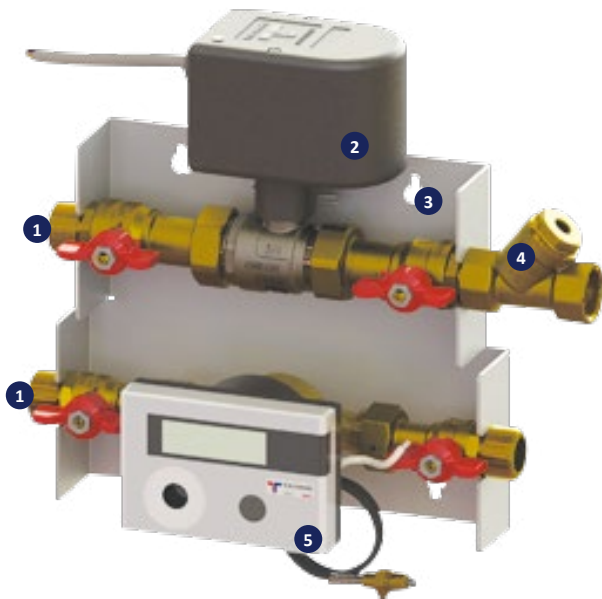

1. Shut-off valves
2. Motorized 2-way zone valve
3. Bracket
4. Flow probe holder
5. Compact thermal energy meter

DOMESTIC WATER

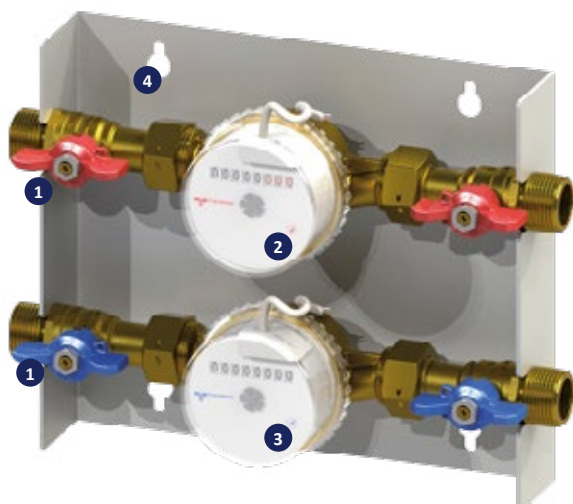

1. Shut-off valves
2. Domestic hot water meter
3. Domestic cold water meter
4. Bracket



10c BASIC METERING SYSTEM

INSTALLATION COMPONENTS



6512P01

Single bracket heating module.



DESCRIPTION

- Motorized 2-way zone valve (230 VAC power supply)
- Shut-off ball valves with 3/4" M and 3/4" F fittings with idle nut or 3/4" M and 1" F with idle nut
- Compact calorie/frigory meter 110 mm interaxle DN15 (3/4")
Qp = 1.5 m³/h or 130mm interaxle DN20 (1") Qp = 2.5 m³/h, with electronic unit and 2x Ø5 mm probes
- "Y" fitting supply temperature probe holder with M10x1 fitting
- Galvanized steel template for wall mounting components

Code	Size	Type	Price €	Unit/Box
650 0078	DN15 Qp = 1.5 m ³ /h	Local reading		1/1
650 0079	DN20 Qp = 2.5 m ³ /h	Local reading		1/1
650 0080	DN15 - 1/10 jmp/l Qp = 1.5 m ³ /h	M-Bus reading		1/1
650 0081	DN20 - 1/10 jmp/l Qp = 2.5 m ³ /h	M-Bus reading		1/1
650 0610	DN15 Qp = 1.5 m ³ /h	Wireless reading		1/1
650 0611	DN20 Qp = 2.5 m ³ /h	Wireless reading		1/1

6510P01

DIMENSIONAL DIAGRAM FUNCTIONAL DIAGRAM

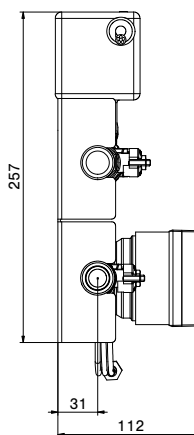
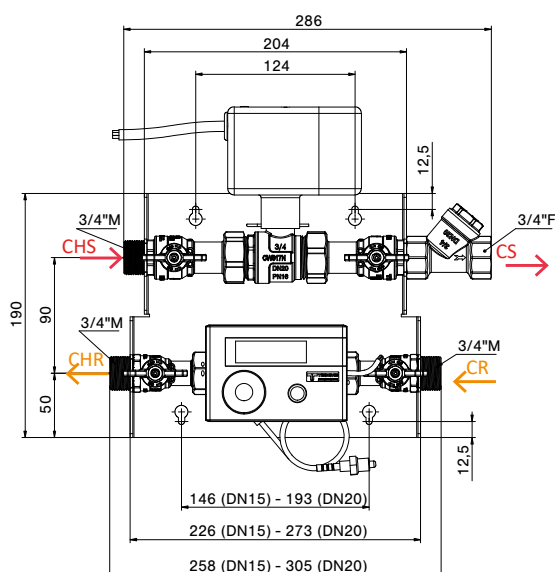

Abbrev.	Description
CHS	Central heating supply
CHR	Central heating return
CS	Consumer supply
CR	Consumer return

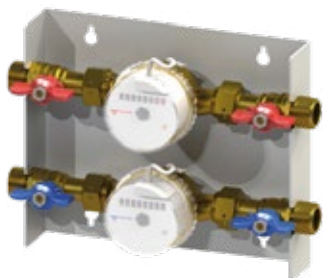

6510P01

Single bracket domestic water module



DESCRIPTION

- Shut-off ball valves with 3/4" M and 3/4" F fittings with idle nut or 3/4" M and 1" F with idle nut (with or without integrated non-return valve)
- Meters for hot and cold domestic water circuit 110 mm interaxle DN15 (3/4") Q3 = 2.5 m³/h or 130 mm interaxle DN20 (1") Q3 = 4.0 m³/h.
- Galvanized steel template for wall mounting components

Code	Size	Type	Price €	Unit/Box
650 0070	DN15 Q3 = 2.5 m ³ /h	Local reading		1/1
650 0071	DN20 Q3 = 4.0 m ³ /h	Local reading		1/1
650 0072	DN15 - 1/10 imp/l Q3 = 2.5 m ³ /h	M-Bus reading		1/1
650 0073	DN20 - 1/10 imp/l Q3 = 4.0 m ³ /h	M-Bus reading		1/1
650 0624	DN15 Q3 = 2.5 m ³ /h	Wireless reading		1/1
650 0625	DN20 Q3 = 4.0 m ³ /h	Wireless reading		1/1

To be combined with art. 6561MR.

IMPORTANT

For the remote control of DHW and DCW consumption using meters configured for M-Bus reading, connecting the meter's pulse emitter to an instrument capable of converting pulses into M-Bus language is necessary:

- via a thermal energy meter configured for M-Bus communication
- via pulse adapter art. 6575C



6561E

Pulse emitter cable. 1/10 pulse/litre.



TECHNICAL SPECIFICATIONS

- Cable length: 1 m

Code	Type	Price €	Unit/Box
651 0085	For 6561C		1/10



6575C

Pulse adapter on M-Bus for meter pairs.

Code	Type	Price €	Unit/Box
651 0074	-		1/10



6561MR

Compact radio module with integrated 868 MHz WIRELESS M-Bus inductive wireless sensor.



TECHNICAL SPECIFICATIONS

- Power supply: lithium battery, service life 11+1 years
- Protection rating: IP67

Code	Type	Price €	Unit/Box
651 0486	For 6561CR - 6561HR		1/40

6510P01

DIMENSIONAL DIAGRAM FUNCTIONAL DIAGRAM

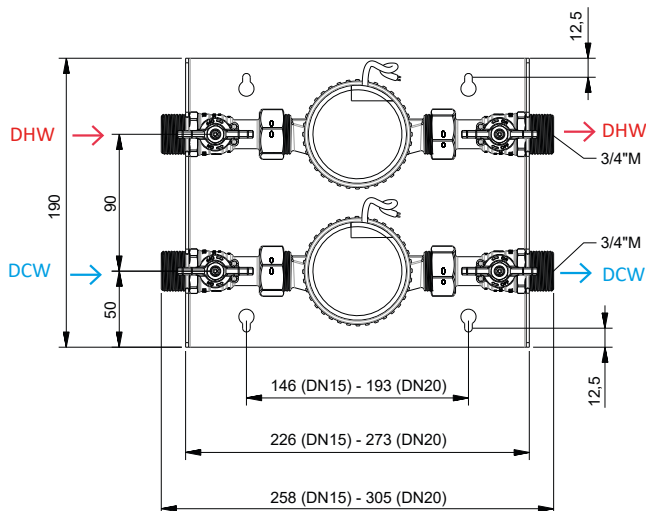

Abbreviation	Description
DHW	Domestic hot water
DCW	Domestic cold water



10_c BASIC HT METERING SYSTEM

INTRODUCTION

Metering module for heating/cooling circuits, mounted on brackets for wall mounting.

It is the ideal solution for metering the consumption of large-scale apartments.

Suitable for flow rates up to 3.5 m³/h (for DN25 measurement) and 6 m³/h (for DN32 measurement). Available with 2 or 3-way zone valve to meet different system requirements.

The pre-installation module is supplied with a stub to allow testing and/or flushing of system. The metering device may be ordered separately in different models according to reading mode.



- | | |
|---------------------------------|--|
| 1. Shut-off valves | 5. Thermal energy meter |
| 2. Motorized 2/3-way zone valve | 6. Return probe holder |
| 3. Bracket | 7. Electronic unit for calorie/frigority calculation |
| 4. Flow probe holder | |

10c BASIC HT METERING SYSTEM

INSTALLATION COMPONENTS

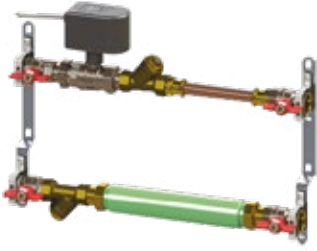

6500G02DN25

Pre-installation module for "BASIC DN25" system with 2-way zone valve, for housing art. 1940. Setup stubs included.

DESCRIPTION

- Shut-off ball valves with 1" F fittings
- Motorized 2-way zone valve (230 VAC supply)
- "Y" supply/return temperature probe holder with M10x1 fitting
- "Pre-installation" stub for testing and/or flushing system and subsequent installation of calorie/frigory meter 260mm interaxle DN25 (1" 1/4)
- Bracket kit for securing components within housing

Code	Type	Price €	Unit/Box
650 0274	DN25 - 2 way		1/1



6500G03DN25

Pre-installation module for "BASIC DN25" system with 3-way zone valve, for housing art. 1940. Setup stubs included.

DESCRIPTION

- Shut-off ball valves with 1" F ports
- 3-way zone valve with motorized by-pass (230 VAC power supply)
- "Y" supply/return temperature probe holder with M10x1 fitting
- "Pre-installation" stub for testing and/or flushing system and subsequent installation of calorie/frigory meter 260mm interaxle DN25 (1" 1/4)
- Bracket kit for securing components within housing

Code	Type	Price €	Unit/Box
650 0275	DN25 - 3 way		1/1

6500G02DN25 6500G03DN25

DIMENSIONAL DIAGRAM FUNCTIONAL DIAGRAM

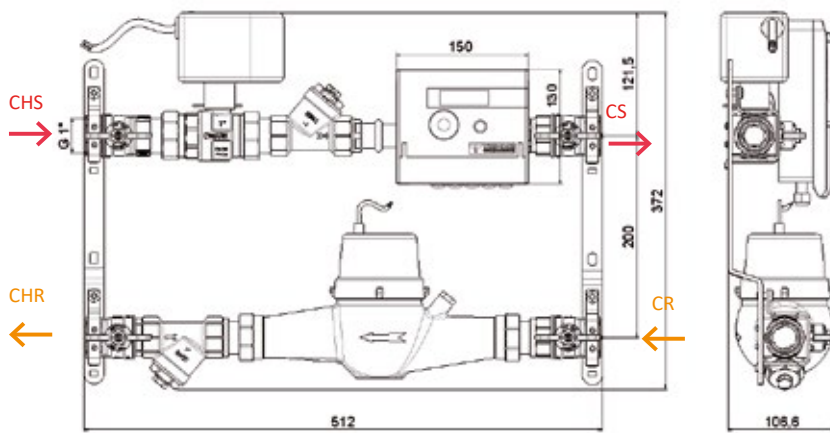

Abbreviation	Description
CHS	Central heating supply
CHR	Central heating return
CS	Consumer supply
CR	Consumer return

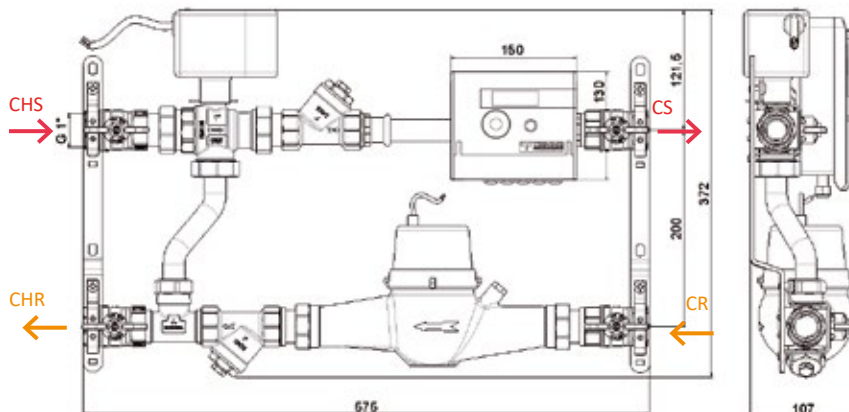

10c BASIC HT METERING SYSTEM

INSTALLATION COMPONENTS

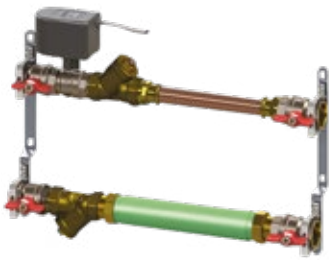

6500G02DN32

Pre-installation module for "BASIC DN32" system with 2-way zone valve, for housing art. 1940. Setup stubs included.

DESCRIPTION

- Shut-off ball valves with 1"1/4 F fittings
- Motorized 2-way zone valve (230 VAC power supply)
- "Y" supply/return temperature probe holder with M10x1 fitting
- "Pre-installation" stub for testing and/or flushing system and subsequent installation of calorie/frigory meter 260mm interaxle DN32 (1" 1/2)
- Bracket kit for securing components within housing

Code	Type	Price €	Unit/Box
650 0276	DN32 - 2 way		1/1



6500G03DN32

Pre-installation module for "BASIC DN32" system with 3-way zone valve, for housing art. 1940. Setup stubs included.

DESCRIPTION

- Shut-off ball valves with 1"1/4 F fittings
- 3-way zone valve with motorized bypass (230 VAC power supply)
- "Y" supply/return temperature probe holder with M10x1 fitting
- "Pre-installation" stub for testing and/or flushing system and subsequent installation of calorie/frigory meter 260mm interaxle DN32 (1" 1/2)
- Bracket kit for securing components within housing

Code	Type	Price €	Unit/Box
650 0277	DN32 - 3 way		1/1

6500G02DN32 6500G03DN32

DIMENSIONAL DIAGRAM FUNCTIONAL DIAGRAM

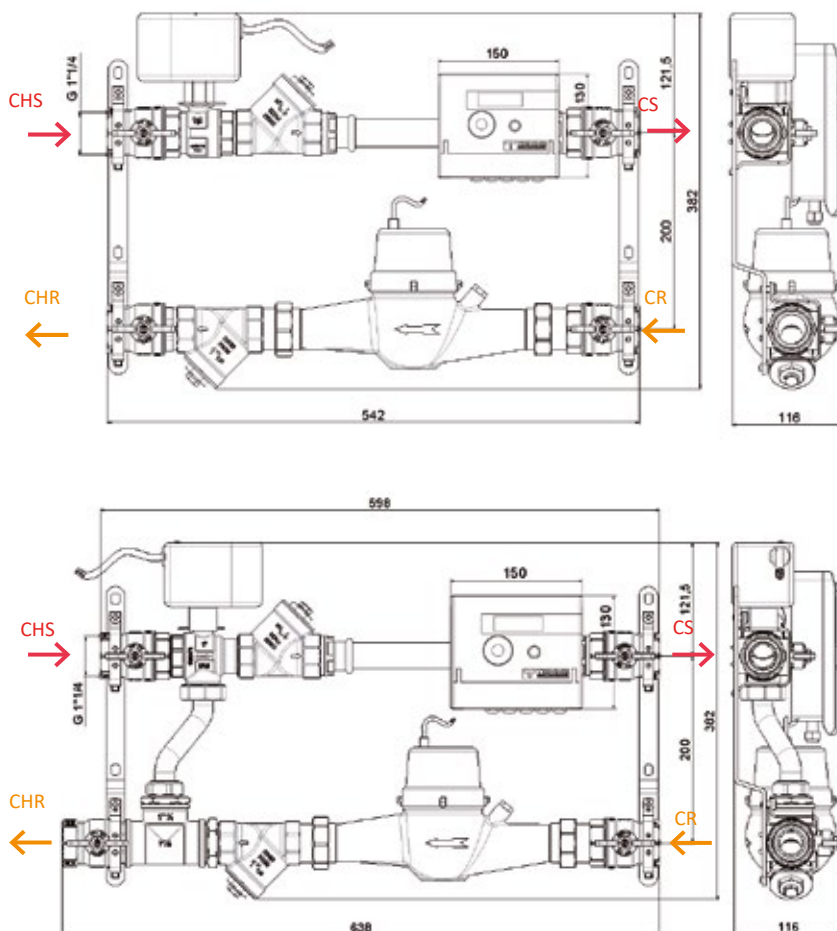

Abbreviation	Description
CHS	Central heating supply
CHR	Central heating return
CS	Consumer supply
CR	Consumer return



6562T

Multiple-jet, super dry, magnetic transmission meter, pulse outlet 1/10 imp/l.



TECHNICAL SPECIFICATIONS

- Brass casing
- Protective metal cap
- Rotatable totalizer for easy reading
- Inlet filter
- Equipped with reed switch pulse emitter
- Maximum operating temperature: 90 °C
- Nominal pressure: PN16
- Certified according to Directive 2014/32/EU (Annex MI-004)

i For installation on horizontal pipes

- i** To be combined with:
- Separate electronics for local reading, M-Bus or wireless (art. 6564C)
 - Pair of PT500 temperature probes for "wet" mounting (art. 6565SB)

Code	Size	Pulse outlet	Price €	Unit/Box
651 0488	DN25 (1"1/4)* qp = 3,5 m³/h	1/10 imp/l		1/2
651 0502	DN32 (1"1/2)* qp = 6 m³/h	1/10 imp/l		1/2

* Size of thread body



6564C

Separate electronic unit for combined heat energy meters.



TECHNICAL SPECIFICATIONS

- Calorie and frigory measurement
- 3V Lithium Replaceable Battery, 10 year service life
- Communication interfaces: Wireless M-Bus + 3 pulse inlets, M-Bus + 3 pulse inlets, volume and energy pulse outlet, calorie and frigory pulse outlet
- IP65 protection rating
- Yearly reading date settable, 15 monthly values viewable from display, 24 monthly values viewable via optical interface or M-Bus
- Dimensions (WxHxD): 150 x 130 x 35 mm

i Programmable pulse factor: to be programmed before installation according to the combined meter pulse features

Code	Type	Price €	Unit/Box
651 0642	Local reading, programmable		1/4
651 0046	M-Bus reading, programmable		1/4
6510495	Wireless reading, programmable		1/4



6565SB

PT500 temperature probe pair (EN 60751) for wells art. 3670PS ("wet" mount).

Code	Type	Price €	Unit/Box
651 0049	∅ 5 mm - 3 m		1/10



1940

Height- and depth-adjustable housing with lock kit.

i Depth adjustable from 120 mm to 170 mm

Code	Type	Price €	Unit/Box
181 0020	600 x 670 x 120 ÷ 170		1/1
181 0016	700 x 670 x 120 ÷ 170		1/1

Housing for 2-way module

Housing for 3-way module

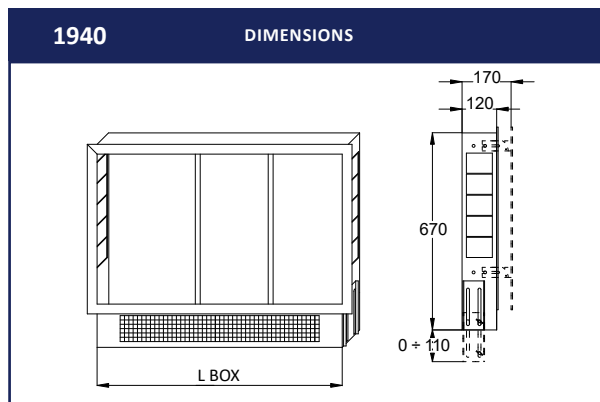

6500I

Thermoformed thermal insulation for "VARIO, FLOOR, DUO, BASIC HT DN32" 2- or 3-way metering module.



TECHNICAL SPECIFICATIONS

- Insulating shell material: PEX closed cell foam

Code	Type	Price €	Unit/Box
650 0119	DN25 - 2 way		1/1
650 0120	DN25 - 3 way		1/1
650 0121	DN32 - 2 way		1/1
650 0122	DN32 - 3 way		1/1



10_D MULTI MODUL METERING SYSTEM

INTRODUCTION

Multi-utility metering module for heating/cooling or domestic water circuits.
Suitable for flow rates up to 2.5 m³/h.

The module can be installed directly within the shaft or in a metal housing (optional) that accommodates up to 5 measurement units.

The DN40 mounting on which the various modules are installed is directly detachable from the main column and **may be positioned both horizontally and vertically** to meet any system requirements and facilitate installation.

The various modules are supplied with stubs to allow the testing and/or flushing of the system.
Metering devices can be ordered separately in different models according to reading mode.

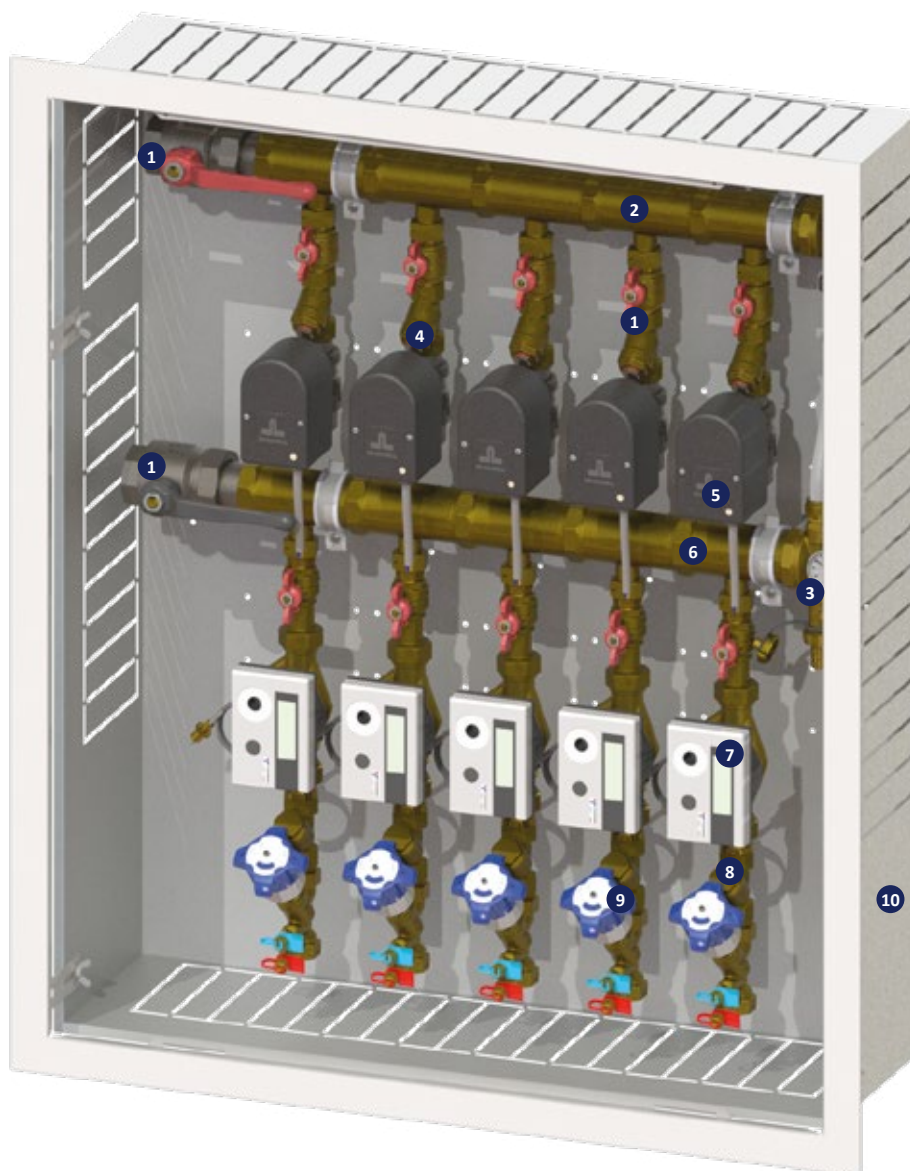

- | | |
|-------------------------------|--|
| 1. Shut-off valves | 7. Compact thermal energy meter |
| 2. Modular supply manifold | 8. Dirt collector filter |
| 3. Bypass terminal kit | 9. Static balancing valve |
| 4. Delivery probe holder | 10. Metal box with locking cover and supports (optional) |
| 5. Motorized 2-way zone valve | |
| 6. Modular return manifold | |

10_D MULTI MODUL METERING SYSTEM

INSTALLATION COMPONENTS



6509MN

Flow rate metering module with 2-way motorized zone valve for "MULTI-MODUL" heating/cooling system

DESCRIPTION

- Manifold 1"1/2 with 3/4" F shunt connection
- Shut-off ball valve
- "Y" fitting probe holder with M10x1 socket for supply temperature reading
- Motorized 2-way zone valve (230 VAC supply)

Modular

May be combined with metal housing art. 1937

Code	Type	Price €	Unit/Box
650 0316	DN40		1/1

6509MN

DIMENSIONAL DIAGRAM FUNCTIONAL DIAGRAM

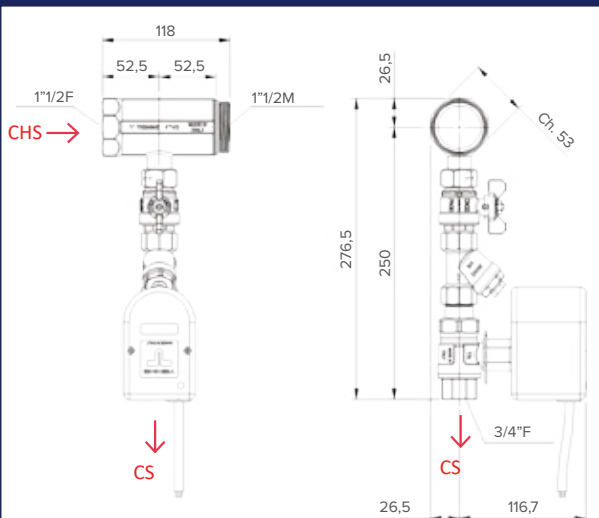

Abbreviation	Description
CHS	Central heating supply
CS	Consumer supply

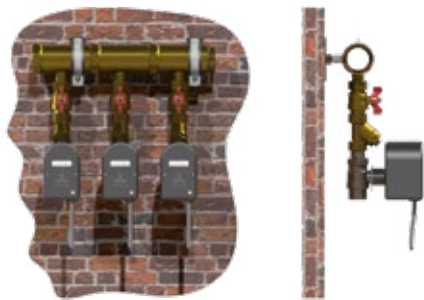

6509RT

Return metering module with pre-installation stub, static balancing valve for "MULTI-MODUL" heating/cooling system

DESCRIPTION

- Manifold 1"1/2 with 3/4" F shunt connection
- Shut-off ball valve
- "Pre-installation" stub for system testing and/or flushing and subsequent installation of the calorie/frigory meter 130 mm interaxis DN20 (1")
- Impurity-removing filter
- Static balancing valve

Modular

May be combined with metal housing art. 1937

Code	Type	Price €	Unit/Box
650 0353	DN40		1/1

6509RT

DIMENSIONAL DIAGRAM FUNCTIONAL DIAGRAM

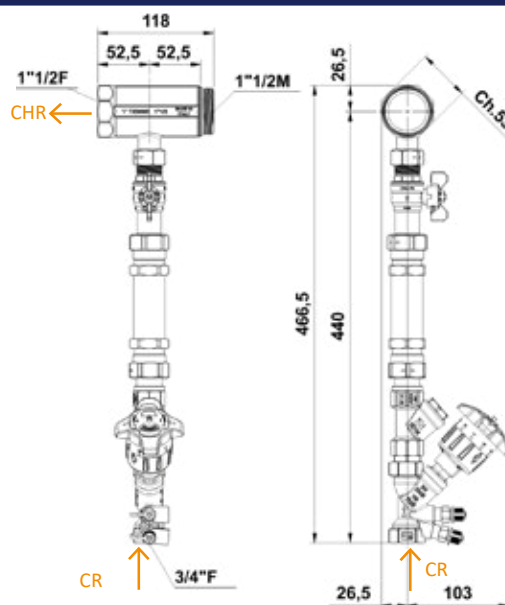

Abbreviation	Description
CHR	Central heating return
CR	Consumer return

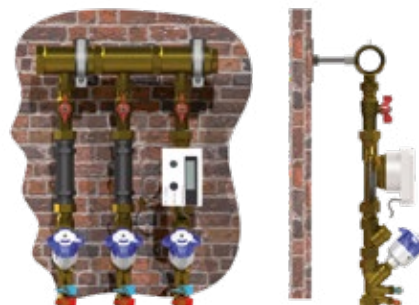



6509SNC

Metering module for domestic hot water with pre-installation stub for "MULTI-MODUL" system

DESCRIPTION

- Manifold 1"1/2 with 3/4" F shunt connection
- Shut-off ball valves (with or without built-in non-return valve)
- "Pre-installation" stub for testing and/or flushing system and subsequent installation of domestic water meter 110 mm (3/4") interaxle DN15

Modular

May be combined with metal housing art. 1937

Code	Type	Price €	Unit/Box
650 0319	DN40 - DHW		1/10

6509SNC

DIMENSIONAL DIAGRAM FUNCTIONAL DIAGRAM

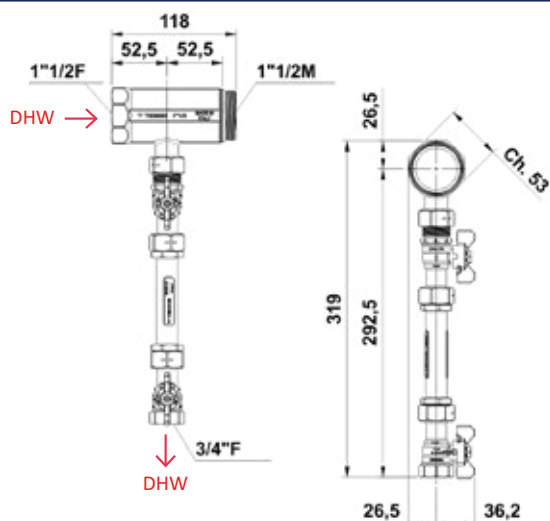

Abbreviation	Description
DHW	Domestic hot water

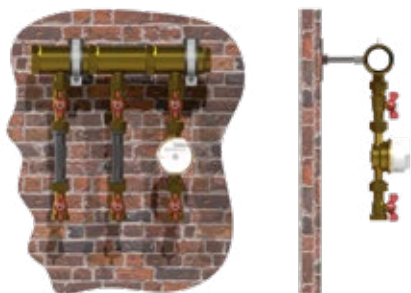

6509SNF

Metering module for domestic cold water with pre-installation stub for "MULTI-MODUL" system

DESCRIPTION

- Manifold 1"1/2 with 3/4" F shunt connection
- Shut-off ball valves (with or without built-in non-return valve)
- "Pre-installation" stub for testing and/or flushing system and subsequent installation of domestic water meter 110 mm (3/4") interaxle DN15

Modular

May be combined with metal housing art. 1937

Code	Type	Price €	Unit/Box
650 0329	DN40 - DCW		1/10

6509SNF

DIMENSIONAL DIAGRAM FUNCTIONAL DIAGRAM

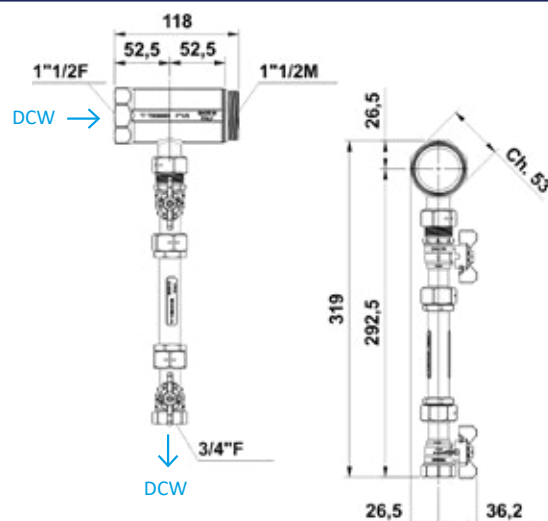

Abbreviation	Description
DCW	Domestic cold water

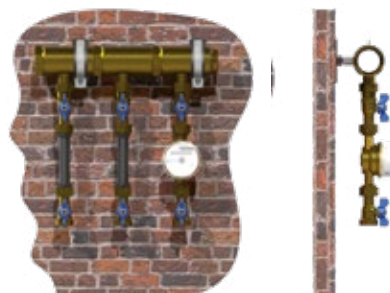

10_D MULTI MODUL METERING SYSTEM

ACCESSORIES



6509K
Pair of clamps.

Code	Type	Price €	Unit/Box
651 0351	L = 20 mm		1/10
651 0352	L = 65 mm		1/10



1882
Male plug with O-ring for manifolds

Code	Type	Price €	Unit/Box
195 0041	1" 1/2		5/70



1880
Female plug for manifolds

Code	Type	Price €	Unit/Box
150 0327	1" 1/2		5/75



6509KBY
Terminal kit with bypass for metering modules art. 6509MN and 6509RT.

Code	Type	Price €	Unit/Box
651 0361	1" 1/2		1/5



6509KT
Terminal kit for metering modules art. 6509MN and 6509RT.

Code	Type	Price €	Unit/Box
651 0448	1" 1/2		1/5



6509IMN
Thermoformed thermal insulation for metering module 6509MN.

TECHNICAL SPECIFICATIONS
• Insulating shell material: PEX closed cell foam

Code	Type	Price €	Unit/Box
650 0411	by art.		1/5



6509IRT
Thermoformed thermal insulation for 6509RT metering module.

TECHNICAL SPECIFICATIONS
• Insulating shell material: PEX closed cell foam

Code	Type	Price €	Unit/Box
650 0412	by art. 6509RT		1/5



6509IBY
Thermoformed thermal insulation for terminal kit with bypass.

TECHNICAL SPECIFICATIONS
• Insulation shell material: PEX closed cell foam

Code	Type	Price €	Unit/Box
650 0421	by art. 6509KBY		1/5



6509IT
Thermoformed thermal insulation for terminal kit.

TECHNICAL SPECIFICATIONS
• Insulating shell material: PEX closed cell foam

Code	Type	Price €	Unit/Box
650 0501	by art. 6509KT		1/5





2121CP

ISO 228 male/female ball valve with aluminium handle for manifolds and Flat washer

Code	Type	Price €	Unit/Box
	 red handle		
212 0122	1"1/2		3/12
	 black handle		
212 0124	1"1/2		3/12



1937

Metal housing for "MULTI-MODUL" system metering modules art. 6509MN and 6509RT or 6509SNC and 6509SNF.

 Depth adjustable from 200 mm to 250 mm

Code	Type	Price €	Unit/Box
181 0128	750 x 900 x 200 ÷ 250		1/1



6560CW 6560C

Compact single-jet calorimeter/ frigorimeter for local reading, M-Bus remote reading and wireless reading.



TECHNICAL SPECIFICATIONS

- Brass casing with 8-digit LCD display electronic unit, 360° positionable and detachable from main body (cable length 50 cm)
- Communication interfaces: Wireless M-Bus + 3 pulse inlets, M-Bus + 3 pulse inlets, local reading + 3 pulse inlets
- 3V Lithium Battery, 10 years service life (replaceable) - setup for external power supply via 3V power supply
- Pt1000 platinum temperature probes
- Nominal pressure: PN16
- Maximum operating temperature: 90 °C
- Protection rating: IP65
- Certified according to Directive 2014/32/EU (Annex MI-004)

 Equipped with 3 pulse inlets

 For installation on horizontal or vertical pipes

 If used in conjunction with cooled water, the detachable electronics may be attached to the bottom of the housing/shaft in order to avoid possible occurrences of condensation.

Code	Size	Type	Price €	Unit/Box
651 0022	DN20 (1")* Qp = 2.5 m³/h	Local reading		1/6
651 0023	DN20 (1")* Qp = 2.5 m³/h	M-Bus reading		1/6
651 0492	DN20 (1")* Qp = 2.5 m³/h	Wireless reading		1/6

* Size of thread body



6560CUW 6568C

Compact ultrasonic calorimeter/ frigorimeter for local reading, M-Bus remote reading and wireless reading.



TECHNICAL SPECIFICATIONS

- Brass casing with 8-digit LCD display electronic unit, 360° positionable and detachable from main body (cable length 85 cm)
- Communication interfaces: Wireless M-Bus + 3 pulse inlets, M-Bus + 3 pulse inlets, local reading + 3 pulse inlets
- 3V Lithium Battery, 10 years service life (replaceable) - setup for external power supply via 3V power supply
- Pt1000 platinum temperature probes
- Nominal pressure: PN16
- Maximum operating temperature: 90 °C
- Protection rating: IP65
- Certified according to Directive 2014/32/EU (Annex MI-004)

 Equipped with 3 pulse inlets

 It provides greater durability and accuracy over time, thanks to the absence of moving parts

 For installation on horizontal or vertical pipes

 If used in conjunction with cooled water, the detachable electronics may be attached to the bottom of the housing/shaft in order to avoid possible occurrences of condensation.

Code	Size	Type	Price €	Unit/Box
651 0601	DN20 (1")* Qp = 2.5 m³/h	Local reading		1/1
651 0056	DN20 (1")* Qp = 2.5 m³/h	M-Bus reading		1/1
651 0494	DN20 (1")* Qp = 2.5 m³/h	Wireless reading		1/6

* Size of thread body



6561C

Single-jet meter for hot or cold water with local or remote M-Bus reading



TECHNICAL SPECIFICATIONS

- Brass casing with direct reading on 8 numbered rollers: 5 (black) for cubic metres – 3 (red) for sub-multiples
- Maximum operating temperature:
 - 50 °C (domestic cold water model)
 - 90 °C (domestic hot water model)
- Nominal pressure (PN) 16 bar
- Certified according to Directive 2014/32/EU (Annex MI-001)

i For installation on horizontal or vertical pipes

i Configured for remote reading if combined with art. 6561E

Code	Size	Type	Price €	Unit/Box
651 0024	DN15 (3/4")* Q3 = 2.5 m ³ /h	domestic cold water		1/12
651 0026	DN15 (3/4")* Q3 = 2.5 m ³ /h	domestic hot water		1/12

* Size of thread body



6561CR 6561HR

Single-jet meter for hot or cold water with local or wireless remote reading



TECHNICAL SPECIFICATIONS

- Brass casing with direct reading on 8 numbered rollers: 5 (black) for cubic metres – 3 (red) for sub-multiples
- Maximum operating temperature:
 - 50 °C (domestic cold water model)
 - 90 °C (domestic hot water model)
- Nominal pressure (PN) 16 bar
- Approved in accordance with Directive 2014/32/EU (Annex MI-001)

i For installation on horizontal or vertical pipes

i Configured for wireless data transmission when combined with art. 6561MR

Code	Size	Type	Price €	Unit/Box
651 0484	DN15 (3/4")* Q3 = 2.5 m ³ /h	domestic cold water		1/12
651 0514	DN15 (3/4")* Q3 = 2.5 m ³ /h	domestic hot water		1/12

* Size of thread body



6561E

Pulse emitter cable. 1/10 pulse/litre.



TECHNICAL SPECIFICATIONS

- Cable length: 1 m

Code	Type	Price €	Unit/Box
651 0085	For 6561C		1/10



6561MR

Compact radio module with integrated 868 MHz WIRELESS M-Bus inductive wireless sensor.



TECHNICAL SPECIFICATIONS

- Power supply: lithium battery, service life 11+1 years
- Protection rating: IP67

Code	Type	Price €	Unit/Box
651 0486	For 6561CR - 6561HR		1/40



6575C

Pulse adapter on M-Bus for meter pairs.

Code	Type	Price €	Unit/Box
651 0074	-		1/10

IMPORTANT

For the remote control of DHW and DCW consumption using meters configured for M-Bus reading, connecting the meter's pulse emitter to an instrument capable of converting pulses into M-Bus language is necessary:

- via a thermal energy meter configured for M-Bus communication
- via pulse adapter art. 6575C



10_E VARIO METERING SYSTEM

INTRODUCTION

Metering module for heating/cooling and domestic water circuits.

It is the ideal solution for metering the consumption of large-scale apartments.

Suitable for flow rates up to 3.5 m³/h (for DN25 measurement) and 6 m³/h (for DN32 measurement). Available with 2- or 3-way zone valve to meet different system requirements.

The pre-installation housing is supplied with stubs to allow system testing and/or flushing. Metering devices can be ordered separately in different models according to reading mode.

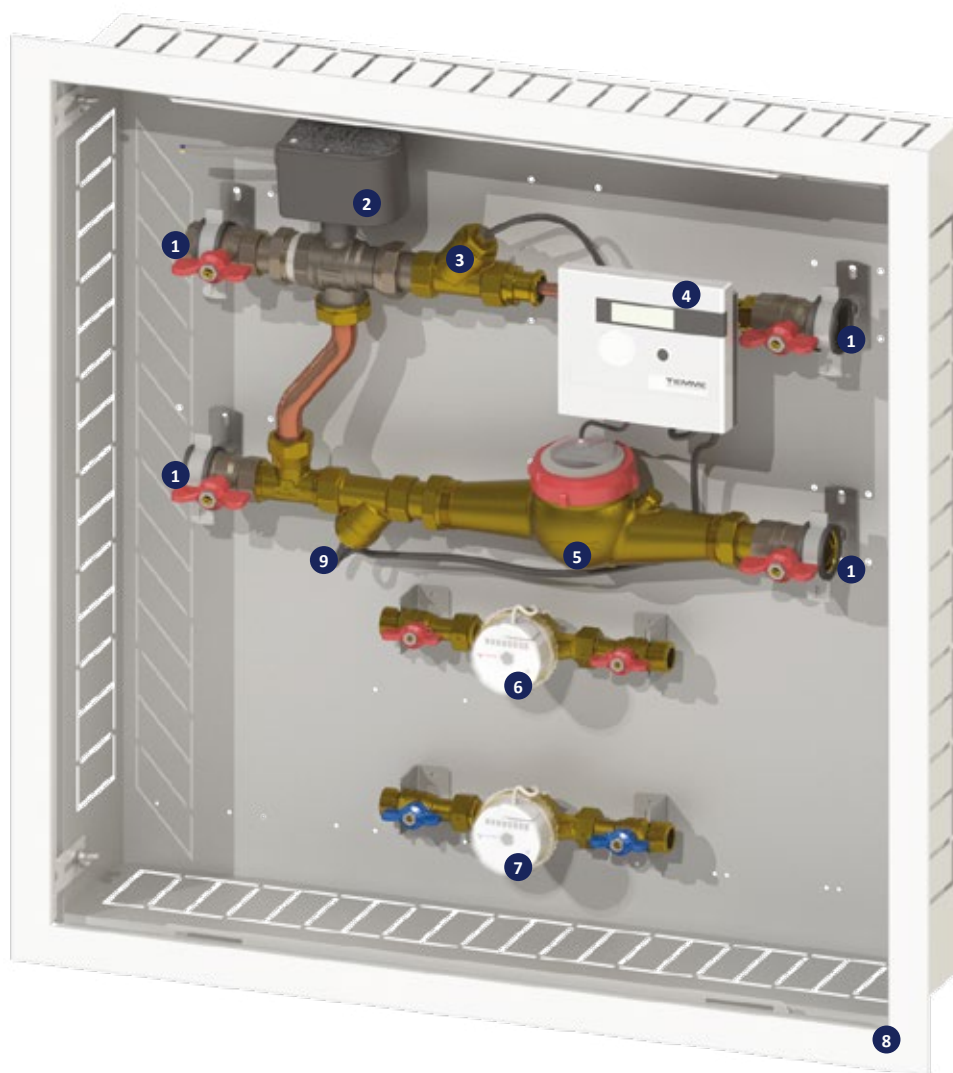

- | | |
|--|--|
| 1. Shut-off valves | 6. Domestic hot water meter |
| 2. Motorized 2/3-way zone valve | 7. Domestic cold water meter |
| 3. Delivery probe holder | 8. Metal housing with locking cover and supports |
| 4. Electronic unit for calorie-frigory calculation | 9. Return probe holder |
| 5. Meter for heating-cooling circuit | |

10_E VARIO METERING SYSTEM

INSTALLATION COMPONENTS



6500C0125V2
Pre-installation metal housing for "VARIO DN25" system, with 2-way zone valve. Setup stubs included.

DESCRIPTION

- Galvanized steel housing complete with painted frame and cover in white RAL 9010
 - Dimensions (WxHxD) 750 x 750 x 140 ÷ 190 mm
- Shut-off ball valves for heating/cooling circuit with 1" F fittings
- Motorized 2-way zone valve (230 VAC power supply)
- "Y" supply/return temperature probe holder with M10x1 fitting
- Shut-off ball valves for domestic water circuits with 3/4" M and 3/4" F fittings with idle nut (with or without built-in non-return valve)
- "Pre-installation" stubs for testing and/or flushing of system and subsequent installation of the calorie/frigory meter 260mm interaxle DN25 (1" 1/4) and 110 mm interaxle DN15 (3/4) domestic water meters
- Bracket kit for securing components within housing

Code	Type	Price €	Unit/Box
650 0395	DN25 - 2 way		1/1



6500C0125V3
Pre-installation metal housing for "VARIO DN25" system, with 3-way zone valve. Setup stubs included.

DESCRIPTION

- Galvanized steel housing with painted frame and cover in white RAL 9010
 - Dimensions (WxHxD) 750 x 750 x 140 ÷ 190 mm
- Shut-off ball valves for heating/cooling circuit with 1" F fittings
- 3-way zone valve with motorized bypass (230 VAC power supply)
- "Y" supply/return temperature probe holder with M10x1 fitting
- Shut-off ball valves for domestic water circuits with 3/4" M and 3/4" F fittings with idle nut (with or without built-in non-return valve)
- "Pre-installation" stubs for testing and/or flushing of system and subsequent installation of the calorie/frigory meter 260mm interaxle DN25 (1" 1/4) and 110 mm interaxle DN15 (3/4) domestic water meters
- Bracket kit for securing components within housing

Code	Type	Price €	Unit/Box
650 0396	DN25 - 3-way		1/1

6500C0125V2
6500C0125V3

DIMENSIONAL DIAGRAM
FUNCTIONAL DIAGRAM

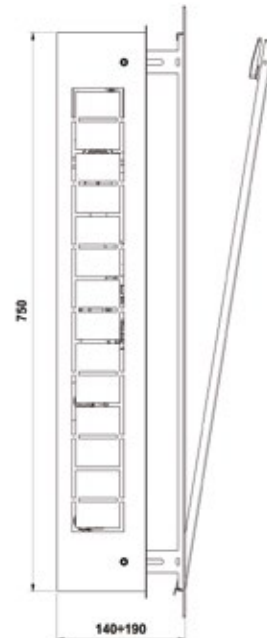
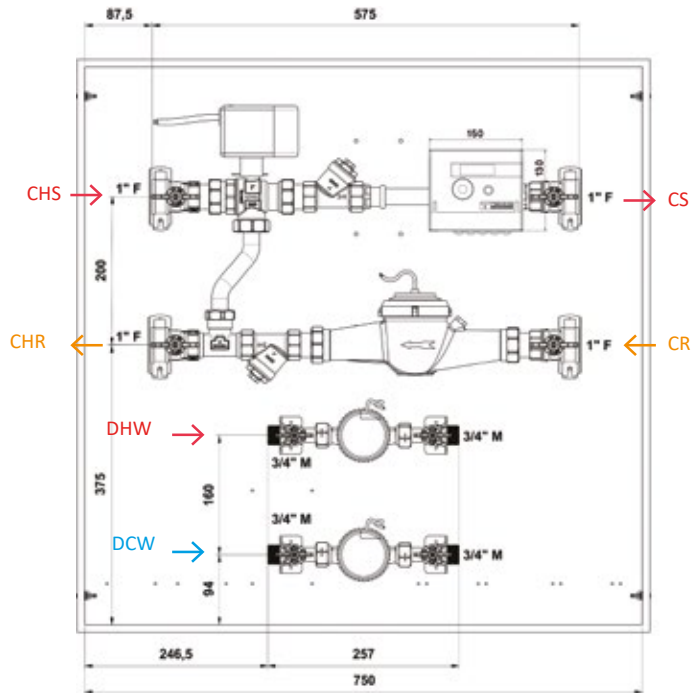

Abbrev.	Description	Abbrev.	Description	Abbrev.	Description
CHS	Central heating supply	CS	Consumer supply	DHW	Domestic hot water
CHR	Central heating return	CR	Consumer return	DCW	Domestic cold water



10_E VARIO METERING SYSTEM

INSTALLATION COMPONENTS



6500C0132V2
Pre-installation metal housing for "VARIO DN32" system, with 2-way zone valve. Setup stubs included.

DESCRIPTION

- Galvanized steel housing with painted frame and cover in white RAL 9010
 - Dimensions (WxHxD) 750 x 750 x 140 ÷ 190 mm
- Shut-off ball valves for heating/cooling circuit with 1"1/4 F fittings
- Motorized 2-way zone valve (230 VAC power supply)
- "Y" supply/return temperature probe holder with M10x1 fitting
- Shut-off ball valves for domestic water circuits with 3/4" M and 3/4" F fittings with idle nut (with or without integrated non-return valve)
- "Pre-installation" stubs for testing and/or flushing of system and subsequent installation of the calorie/frigory meter 260mm (1" 1/2) interaxle DN32 and 110 mm (3/4) interaxle DN15 domestic water meters.
- Bracket kit for securing components within housing

Code	Type	Price €	Unit/Box
650 0397	DN32 - 2-way		1/1

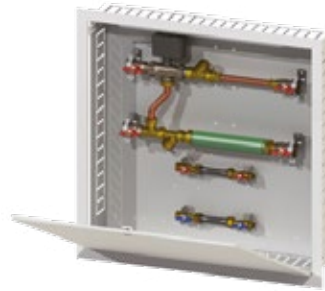

6500C0132V3
Pre-installation metal housing for "VARIO DN32" system, with 3-way zone valve. Setup stubs included.

DESCRIPTION

- Galvanized steel housing with painted frame and cover in white RAL 9010
 - Dimensions (WxHxD) 750 x 750 x 140 ÷ 190 mm
- Shut-off ball valves for heating/cooling circuit with 1"1/4 F fittings
- 3-way zone valve with motorized bypass (230 VAC power supply)
- "Y" supply/return temperature probe holder with M10x1 fitting
- Shut-off ball valves for domestic water circuits with 3/4" M and 3/4" F fittings with idle nut (with or without built-in non-return valve)
- "Pre-installation" stubs for testing and/or flushing of system and subsequent installation of the calorie/frigory meter 260mm (1" 1/2) interaxle DN32 and 110 mm (3/4) interaxle DN15 domestic water meters.
- Bracket kit for securing components within housing

Code	Type	Price €	Unit/Box
650 0398	DN32 - 3-way		1/1

6500C0132V2
6500C0132V3

DIMENSIONAL DIAGRAM
FUNCTIONAL DIAGRAM

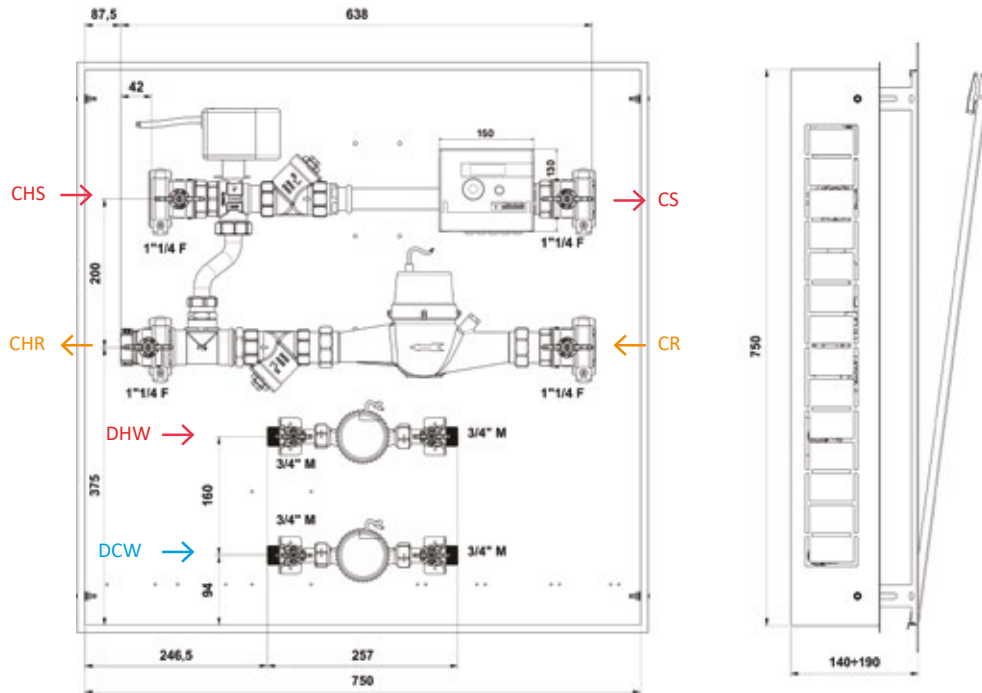

Abbrev.	Description	Abbrev.	Description	Abbrev.	Description
CHS	Central heating supply	CS	Consumer supply	DHW	Domestic hot water
CHR	Central heating return	CR	Consumer return	DCW	Domestic cold water



6562T

Multiple-jet, super dry, magnetic transmission meter, pulse outlet 1/10 imp/l.



TECHNICAL SPECIFICATIONS

- Brass casing
- Protective metal cap
- Rotatable totalizer for easy reading
- Inlet filter
- Equipped with reed switch pulse emitter
- Maximum operating temperature: 90 °C
- Nominal pressure: PN16
- Certified according to Directive 2014/32/EU (Annex MI-004)

i For installation on horizontal or vertical pipes

- i** To be combined with:
- Separate electronics for local reading, M-Bus or wireless (art. 6564C)
 - Pair of PT500 temperature probes for "wet" mounting (art. 6565SB)

Code	Size	Pulse outlet	Price €	Unit/Box
651 0488	DN25 (1"1/4)* Qp = 3,5 m³/h	1/10 imp/l		1/2
651 0502	DN32 (1"1/2)* Qp = 6 m³/h	1/10 imp/l		1/2

* Size of thread body



6565SB

Temperature probe pair Pt 500 (EN 60751) for wells art. 3670PS ("wet" mounting).

Code	Type	Price €	Unit/Box
651 0049	∅ 5 mm - 3 m		1/10



6564C

Separate electronic unit for combined heat energy meters.



TECHNICAL SPECIFICATIONS

- Calorie and frigory measurement
- 3V replaceable lithium battery, 10 year service life
- Communication interfaces: Wireless M-Bus + 3 pulse inlets, M-Bus + 3 pulse inlets, volume and energy pulse outlet, calorie and frigory pulse outlet
- IP65 protection rating
- Settable annual reading date, 15 monthly values viewable on display, 24 monthly values viewable via optical interface or M-Bus
- Dimensions (WxHxD): 150 x 130 x 35 mm

i Programmable pulse factor: to be programmed before installation according to the combined meter pulse features

Code	Type	Price €	Unit/Box
651 0642	Local reading, programmable		1/4
651 0046	M-Bus reading, programmable		1/4
6510495	Wireless reading, programmable		1/4



6500I

Thermoformed thermal insulation for "VARIO, FLOOR, DUO, BASIC HT DN32" 2- or 3-way metering module.

TECHNICAL SPECIFICATIONS

- Insulating shell material: PEX closed cell foam

Code	Type	Price €	Unit/Box
650 0119	DN25 - 2-way		1/1
650 0120	DN25 - 3-way		1/1
650 0121	DN32 - 2-way		1/1
650 0122	DN32 - 3-way		1/1





6561C

Single-jet meter for hot or cold water with local or remote M-Bus reading.



TECHNICAL SPECIFICATIONS

- Brass casing with direct reading on 8 numbered rollers: 5 (black) for cubic metres – 3 (red) for sub-multiples
- Maximum operating temperature:
 - 50 °C (domestic cold water model)
 - 90 °C (domestic hot water model)
- Nominal pressure (PN) 16 bar
- Certified according to Directive 2014/32/EU (Annex MI-001)

i For installation on horizontal or vertical pipes

i Configured for remote reading if combined with art. 6561E

Code	Size	Type	Price €	Unit/Box
651 0024	DN15 (3/4")* Q3 = 2.5 m ³ /h	domestic cold water		1/12
651 0026	DN15 (3/4")* Q3 = 2.5 m ³ /h	domestic hot water		1/12

* Size of thread body



6561E

Pulse emitter cable. 1/10 pulse/litre.



TECHNICAL SPECIFICATIONS

- Cable length: 1 m

Code	Type	Price €	Unit/Box
651 0085	For 6561C		1/10



6561CR 6561HR

Single-jet meter for hot or cold water with local or wireless remote reading



TECHNICAL SPECIFICATIONS

- Brass casing with direct reading on 8 numbered rollers: 5 (black) for cubic metres – 3 (red) for sub-multiples
- Maximum operating temperature:
 - 50 °C (domestic cold water model)
 - 90 °C (domestic hot water model)
- Nominal pressure (PN) 16 bar
- Approved in accordance with Directive 2014/32/EU (Annex MI-001)

i For installation on horizontal or vertical pipes

i Configured for wireless data transmission when combined with art. 6561MR

Code	Size	Type	Price €	Unit/Box
651 0484	DN15 (3/4")* Q3 = 2.5 m ³ /h	domestic cold water		1/12
651 0514	DN15 (3/4")* Q3 = 2.5 m ³ /h	domestic hot water		1/12

* Size of thread body



6561MR

Compact radio module with integrated 868 MHz WIRELESS M-Bus inductive wireless sensor.



TECHNICAL SPECIFICATIONS

- Power supply: lithium battery, service life 11+1 years
- Protection rating: IP67

Code	Type	Price €	Unit/Box
651 0486	For 6561CR - 6561HR		1/40

10_F FLOOR DN20 METERING SYSTEM

INTRODUCTION

Metering module for heating/cooling and domestic water circuits with system-side connection fittings at the bottom of the housing.

It is the ideal solution for horizontal distribution systems.

Available with 2- or 3- way zone valve.

The presence of a bypass differential valve makes it an extremely precise and functional system.

Suitable for flow rates up to 2.5 m³/h.

The pre-installation housing is supplied with stubs to allow system testing and/or flushing.

Metering devices can be ordered separately in different models according to reading mode.

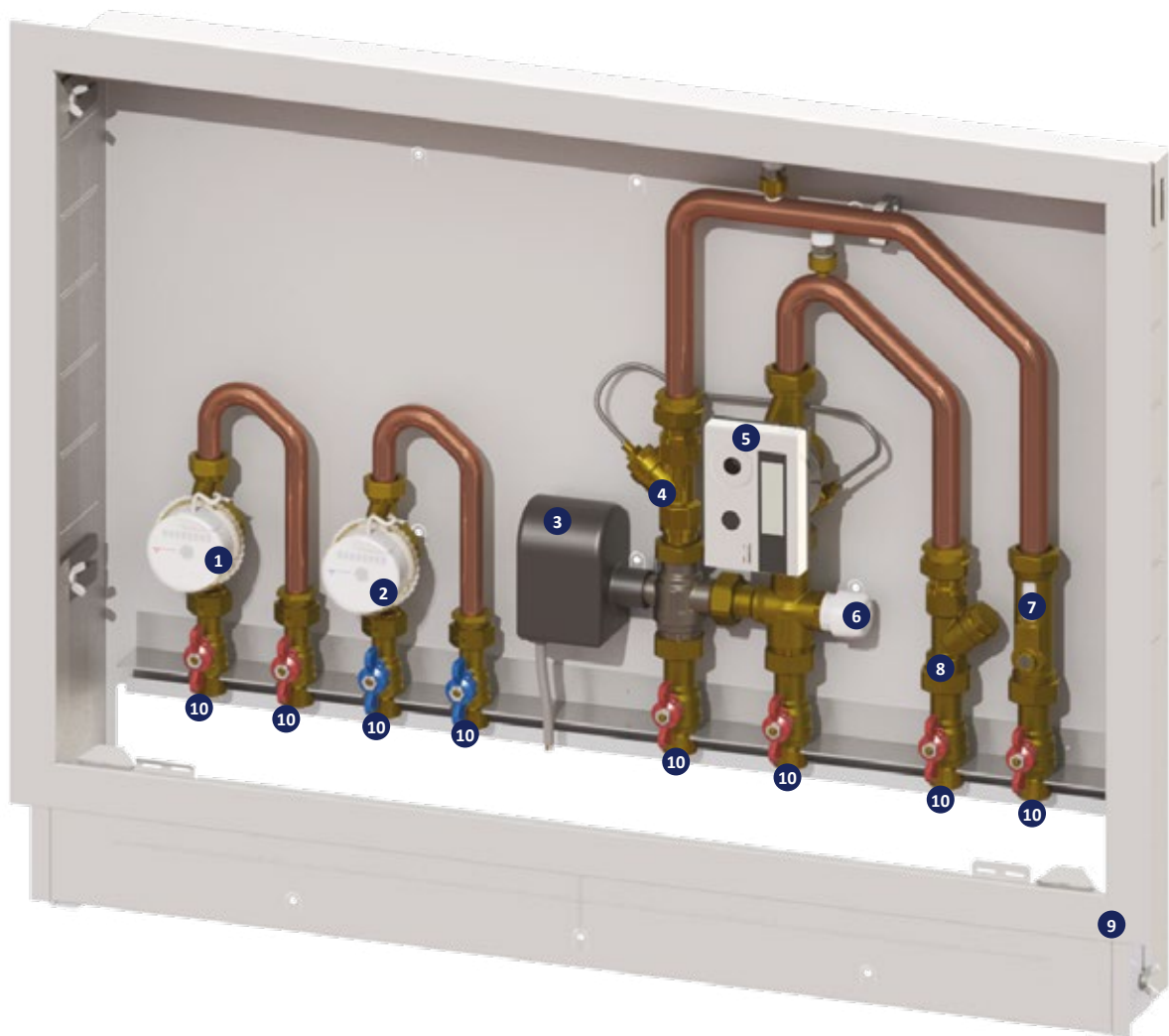

1. Domestic hot water meter
2. Domestic cold water meter
3. Motorized 2/3-way zone valve
4. Delivery probe holder
5. Compact thermal energy meter

6. Differential bypass valve
7. Flow meter
8. Impurity-trapping filter
9. Metal housing with locking cover and supports
10. Shut-off valves



10_F FLOOR DN20 METERING SYSTEM

INSTALLATION COMPONENTS



6501C0120

Pre-installation metal casing for "FLOOR DN20" system. Setup stubs included

DESCRIPTION

- Galvanized steel housing with painted frame and cover in white RAL 9010
- Dimensions (WxHxD) 850 x 670 x 120 ÷ 170 mm
- Shut-off ball valves for heating/cooling circuit with 3/4" M and 1" F fittings with idle nut
- Shut-off ball valves for domestic water circuits with 3/4" M and 3/4" F fittings with idle nut (with or without built-in non-return valve)
- "Pre-installation" stubs for testing and/or flushing system and subsequent installation of the metering module
- Galvanized steel template for mounting the shut-off valves at the bottom of the casing

Code	Type	Price €	Unit/Box
650 0026	850 x 670 x 120 ÷ 170		1/1

6501G02

Metering module consisting of compact calorimeter, 2-way motorized zone valve and 2 "FLOOR DN20" meters for DHW and DCW



DESCRIPTION

- Motorized 2-way zone valve (230 VAC power supply)
- "Y" fitting supply temperature probe holder with M10x1 fitting
- Balancing valve (regulation 4÷15 or 8÷30 l/min)
- Impurity-removing "Y" filter
- Compact calorie/frigorie counter 130 mm (1") interaxle DN20
Qp = 2.5 m³/h, with electronic unit and 2x probes Ø5 mm
- Meters for hot and cold domestic water circuit 110 mm interaxle DN15 (3/4") Q3 = 2.5 m³/h
- Copper fittings for connecting components

i For pre-installation housing art. 6501C0120

Code	Flow meter adjustment	Type	Price €	Unit/Box
650 0027	4 - 15 l/min	Local reading		1/1
650 0028	8 - 30 l/min	Local reading		1/1
650 0030	4 - 15 l/min	M-Bus reading		1/1
650 0031	8 - 30 l/min	M-Bus reading		1/1
650 0612	4 - 15 l/min	Wireless reading		1/1
650 0613	8 - 30 l/min	Wireless reading		1/1

6501G03

Metering module consisting of compact calorimeter counter units, 3-way motorized zone valve and 2 "FLOOR DN20" meters for DHW and DCW



DESCRIPTION

- Motorized 3-way zone valve (230 VAC power supply)
- Differential bypass (0÷400 mbar adjustable range)**
- "Y" fitting supply temperature probe holder with M10x1 fitting
- Balancing valve (4÷15 or 8÷30 l/min adjustable range)
- Impurity-removing "Y" filter
- Compact calorie/frigorie meter 130 mm (1") interaxle DN20
Qp = 2.5 m³/h, with electronic unit and 2x probes Ø5 mm
- Meters for hot and cold domestic water circuit 110 mm interaxle DN15 (3/4") Q3 = 2.5 m³/h
- Copper fittings for components connection

i For pre-installation housing art. 6501C0120

Code	Flow meter adjustment	Type	Price €	Unit/Box
650 0033	4 - 15 l/min	Local reading		1/1
650 0034	8 - 30 l/min	Local reading		1/1
650 0036	4 - 15 l/min	M-Bus reading		1/1
650 0037	8 - 30 l/min	M-Bus reading		1/1
650 0614	4 - 15 l/min	Wireless reading		1/1
650 0615	8 - 30 l/min	Wireless reading		1/1

6501I

Thermoformed thermal insulation for metering module



TECHNICAL SPECIFICATIONS

- Insulation shell material: PEX closed cell foam

Code	Type	Price €	Unit/Box
650 0058	FLOOR - DN20		1/5

10_F FLOOR DN20 METERING SYSTEM

INSTALLATION COMPONENTS

6501C0120 + 6501G02
6501C0120 + 6501G03

DIMENSIONAL DIAGRAM
FUNCTIONAL DIAGRAM

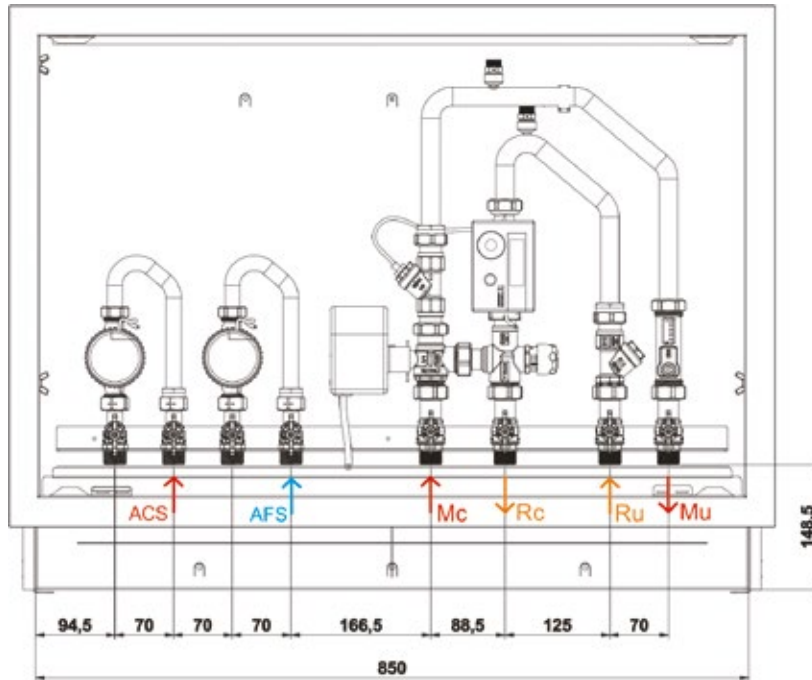

Abbrev.	Description
CHS	Central heating supply
CHR	Central heating return
CS	Consumer supply
CR	Consumer return
DHW	Domestic hot water
DCW	Domestic cold water



10_F FLOOR METERING SYSTEM DN25 - DN32

INTRODUCTION

Metering module for heating/cooling and domestic water circuits with system-side connection fittings at the bottom of the housing.

The ideal solution when metering consumption across large-footprint apartments with horizontal distribution.

Suitable for flow rates up to 3.5 m³/h (DN25) and 6 m³/h (DN32).

Available with 2- or 3-way zone valve to meet different system requirements.

The pre-installation housing is supplied with stubs to allow system testing and/or flushing.

Metering devices can be ordered separately in different models according to reading mode.

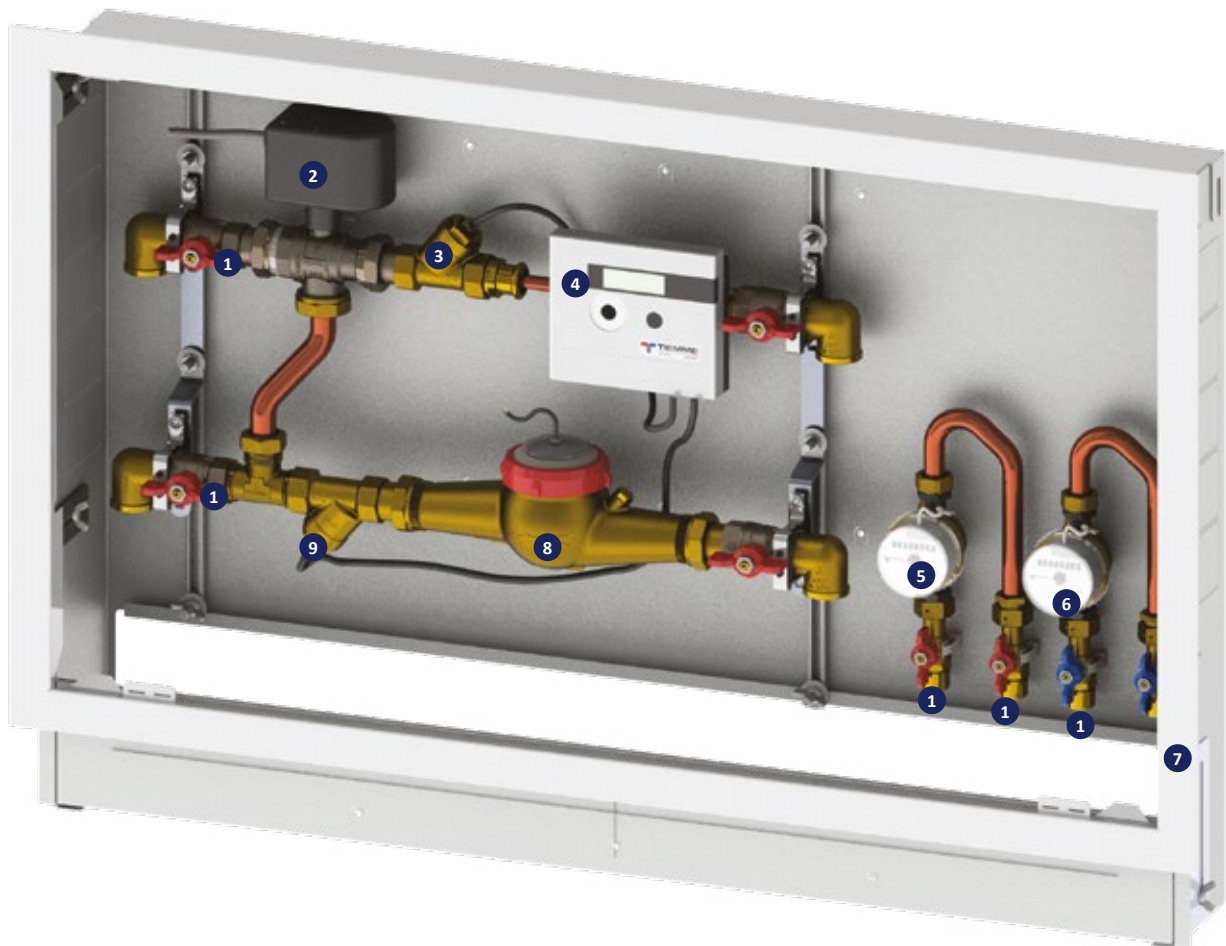

- | | |
|--|--|
| 1. Shut-off valve | 6. Domestic cold water meter |
| 2. Motorized 2/3-way zone valve | 7. Metal housing with locking cover and supports |
| 3. Flow probe holder | 8. Meter for heating - cooling circuit |
| 4. Electronic unit of calculation for calories - frigorities | 9. Return probe holder |
| 5. Domestic hot water meter | |

10_F FLOOR METERING SYSTEM DN25 - DN32

INSTALLATION COMPONENTS

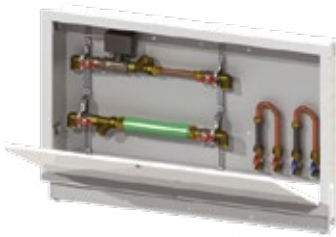

6501C0125V2

Pre-installation metal housing for "FLOOR DN25 WITH 2-WAY ZONE VALVE" system. Setup stubs included.

DESCRIPTION

- Galvanized steel housing with painted frame and cover in white RAL 9010
- Dimensions (WxHxD) 1000 x 670 x 120 ÷ 170 mm
- Shut-off ball valves for heating/cooling circuit and bend fittings with 1" F connections
- Motorized 2-way zone valve (230 VAC power supply)
- "Y" fitting supply/return temperature probe with M10x1 fitting
- Shut-off ball valves for domestic water circuits with 3/4" M and 3/4" F fittings with idle nut (with or without built-in non-return valve)
- "Pre-installation" stubs for testing and/or flushing of system and subsequent installation of the calorie/frigorie meter 260mm (1" 1/4) interaxle DN25 and 110 mm (3/4) interaxle DN15 domestic water meters.
- Copper fittings for component connection
- Bracket kit for securing components within housing

Code	Type	Price €	Unit/Box
650 0189	DN25 - 2-way		1/1

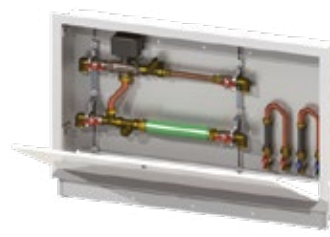

6501C0125V3

Pre-installation metal housing for "FLOOR DN25 WITH 3-WAY ZONE VALVE" system. Setup stubs included.

DESCRIPTION

- Galvanized steel housing with painted frame and cover in white RAL 9010
- Dimensions (WxHxD) 1000 x 670 x 120 ÷ 170 mm
- Shut-off ball valves for heating/cooling circuit and bend fittings with 1" F connections
- 3-way zone valve with motorized bypass (230 VAC power supply)
- "Y" fitting supply/return temperature probe with M10x1 fitting
- Shut-off ball valves for domestic water circuits with 3/4" M and 3/4" F fittings with idle nut (with or without built-in non-return valve)
- "Pre-installation" stubs for testing and/or flushing of system and subsequent installation of the calorie/frigorie meter 260mm (1" 1/4) interaxle DN25 and 110 mm (3/4) interaxle DN15 domestic water meters.
- Copper fittings for component connection
- Bracket kit for securing components within housing

Code	Type	Price €	Unit/Box
650 0101	DN25 - 3-way		1/1

6501C0125V2 6501C0125V3

DIMENSIONAL DIAGRAM FUNCTIONAL DIAGRAM

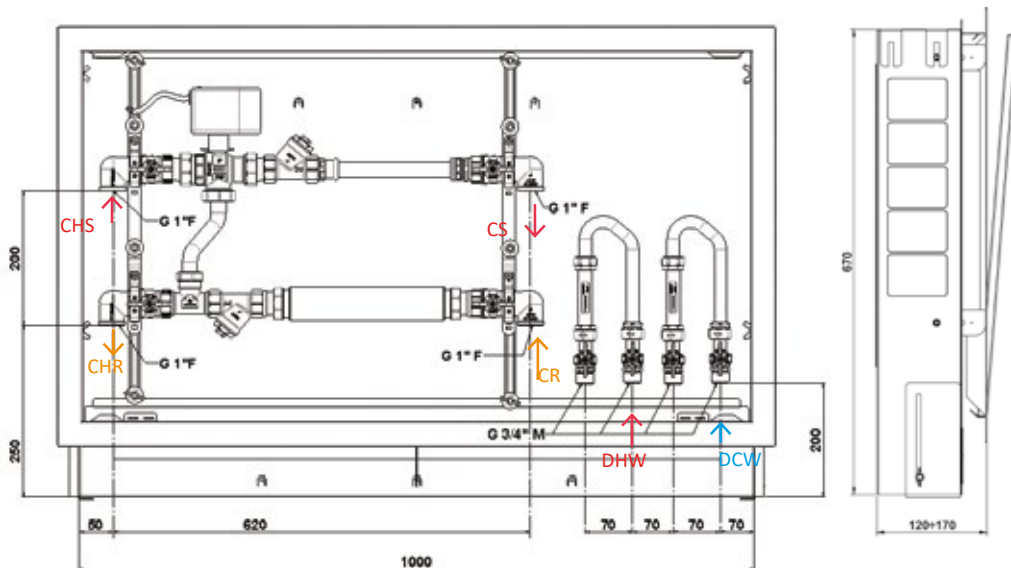

Abbrev.	Description	Abbrev.	Description
CHS	Central heating supply	CR	Consumer return
CHR	Central heating return	DHW	Domestic hot water
CS	Consumer supply	DCW	Domestic cold water



10_F FLOOR METERING SYSTEM DN25 - DN32

INSTALLATION COMPONENTS

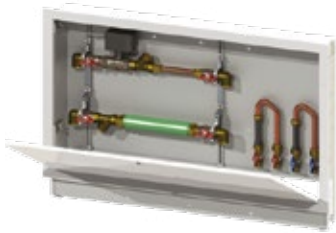

6501C0132V2
Pre-installation metal housing for "FLOOR DN32" system, with 2-way zone valve. Setup stubs included.

DESCRIPTION

- Galvanized steel housing with painted frame and cover in white RAL 9010
- Dimensions (WxHxD) 1200 x 670 x 120 ÷ 170 mm
- Shut-off ball valves for heating/cooling circuit and bend fittings with 1"1/4 F connections
- Motorized 2-way zone valve (230 VAC power supply)
- "Y" fitting supply/return temperature probe with M10x1 fitting
- Shut-off ball valves for domestic water circuits with 3/4" M and 3/4" F fittings with idle nut (with or without built-in non-return valve)
- "Pre-installation" stubs for testing and/or flushing of system and subsequent installation of the calorie/frigory meter 260mm (1" 1/2) interaxle DN32 and 110 mm (3/4) interaxle DN15 domestic water meters.
- Copper fittings for component connection
- Bracket kit for securing components within housing

Code	Type	Price €	Unit/Box
650 0190	DN32 - 2-way		1/1



6501C0132V3
Pre-installation metal housing for "FLOOR DN32" system, with 3-way zone valve. Setup stubs included.

DESCRIPTION

- Galvanized steel housing with painted frame and cover in white RAL 9010
- Dimensions (WxHxD) 1200 x 670 x 120 ÷ 170 mm
- Shut-off ball valves for heating/cooling circuit and bend fittings with 1"1/4 F connections
- 3-way zone valve with motorized bypass (230 VAC power supply)
- "Y" fitting supply/return temperature probe with M10x1 fitting
- Shut-off ball valves for domestic water circuits with 3/4" M and 3/4" F fittings with idle nut (with or without built-in non-return valve)
- "Pre-installation" stubs for testing and/or flushing of system and subsequent installation of the calorie/frigory meter 260mm (1" 1/2) interaxle DN32 and 110 mm (3/4) interaxle DN15 domestic water meters.
- Copper fittings for component connection
- Bracket kit for securing components within housing

Code	Type	Price €	Unit/Box
650 0191	DN32 - 3-way		1/1

**6501C0132V2
6501C0132V3**

**DIMENSIONAL DIAGRAM
FUNCTIONAL DIAGRAM**

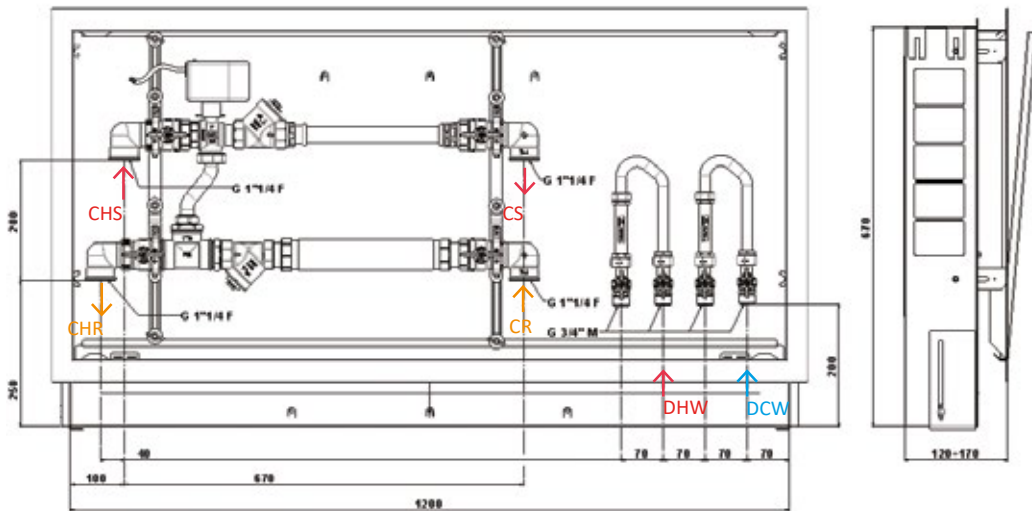

Abbrev.	Description	Abbrev.	Description
CHS	Central heating supply	CR	Consumer return
CHR	Central heating return	DHW	Domestic hot water
CS	Consumer supply	DCW	Domestic cold water



6562T

Multiple-jet, super dry, magnetic transmission meter, pulse output 1/10 imp/l.



TECHNICAL SPECIFICATIONS

- Brass casing
- Protective metal cap
- Rotatable totalizer for ease of reading
- Inlet filter
- Equipped with reed switch pulse emitter
- Maximum operating temperature: 90 °C
- Nominal pressure: PN16
- Certified according to Directive 2014/32/EU (Annex MI-004)

i For installation on horizontal or vertical pipes

- i** To be combined with:
- Separate electronics for local reading, M-Bus or wireless (art. 6564C)
 - Pair of PT500 temperature probes for "wet" mounting (art. 6565SB)

Code	Size	Pulse outlet	Price €	Unit/Box
651 0488	DN25 (1"1/4)* Qp = 3.5 m³/h	1/10 imp/l		1/2
651 0502	DN32 (1"1/2)* Qp = 6 m³/h	1/10 imp/l		1/2

* Size of thread body



6565SB

Pair of PT500 temperature probes (EN 60751) for wells art. 3670PS ("wet" mount).

Code	Type	Price €	Unit/Box
651 0049	∅ 5 mm - 3 m		1/10



6564C

Separate electronic unit for combined heat energy meters.



TECHNICAL SPECIFICATIONS

- Calorie and frigory measurement
- 3V replaceable lithium battery, 10 year service life
- Communication interfaces: Wireless M-Bus + 3 pulse inlets, M-Bus + 3 pulse inlets, volume and energy pulse outlet, calorie and frigory pulse outlet
- IP65 protection rating
- Settable annual reading date, 15 monthly values viewable on display, 24 monthly values viewable via optical interface or M-Bus
- Dimensions (WxHxD): 150 x 130 x 35 mm

i Programmable pulse factor: to be programmed before installation according to the combined meter pulse features

Code	Type	Price €	Unit/Box
651 0642	Local reading, programmable		1/4
651 0046	M-Bus reading, programmable		1/4
6510495	Wireless reading, programmable		1/4



6500I

Thermoformed thermal insulation for "VARIO, FLOOR, DUO, BASIC HT DN32" 2- or 3-way metering module.

TECHNICAL SPECIFICATIONS

- Insulation shell material: PEX closed cell foam

Code	Type	Price €	Unit/Box
650 0119	DN25 - 2-way		1/1
650 0120	DN25 - 3-way		1/1
650 0121	DN32 - 2-way		1/1
650 0122	DN32 - 3-way		1/1





6561C

Single-jet meter for hot or cold water with local or remote M-Bus reading.



TECHNICAL SPECIFICATIONS

- Brass casing with direct reading on 8 numbered rollers: 5 (black) for cubic metres – 3 (red) for sub-multiples
- Maximum operating temperature:
 - 50 °C (domestic cold water model)
 - 90 °C (domestic hot water model)
- Nominal pressure (PN) 16 bar
- Certified according to Directive 2014/32/EU (Annex MI-001)

i For installation on horizontal or vertical pipes

i Configured for remote reading if combined with art. 6561E

Code	Size	Type	Price €	Unit/Box
651 0024	DN15 (3/4")* Q3 = 2.5 m ³ /h	domestic cold water		1/12
651 0026	DN15 (3/4")* Q3 = 2.5 m ³ /h	domestic hot water		1/12

* Size of thread body



6561E

Pulse emitter cable. 1/10 pulse/litre



TECHNICAL SPECIFICATIONS

- Cable length: 1 m

Code	Type	Price €	Unit/Box
651 0085	For 6561C		1/10



6561CR 6561HR

Single-jet meter for hot or cold water with local or wireless remote reading



TECHNICAL SPECIFICATIONS

- Brass casing with direct reading on 8 numbered rollers: 5 (black) for cubic metres – 3 (red) for sub-multiples
- Maximum operating temperature:
 - 50 °C (domestic cold water model)
 - 90 °C (domestic hot water model)
- Nominal pressure (PN) 16 bar
- Approved in accordance with Directive 2014/32/EU (Annex MI-001)

i For installation on horizontal or vertical pipes

i Configured for wireless data transmission when combined with art. 6561MR

Code	Size	Type	Price €	Unit/Box
651 0484	DN15 (3/4")* Q3 = 2.5 m ³ /h	domestic cold water		1/12
651 0514	DN15 (3/4")* Q3 = 2.5 m ³ /h	domestic hot water		1/12

* Size of thread body



6561MR

Compact radio module with integrated 868 MHz WIRELESS M-Bus inductive wireless sensor



TECHNICAL SPECIFICATIONS

- Power supply: lithium battery, service life 11+1 years
- Protection rating: IP67

Code	Type	Price €	Unit/Box
651 0486	For 6561CR - 6561HR		1/40

10_G HEAT METERING SYSTEM

INTRODUCTION

Metering module for heating-only circuits with instant DHW production via steel exchanger.

The instant production of domestic hot water avoids the energy losses along the distribution lines and guarantees DHW at the correct temperature everywhere throughout the building without the need for a recycling network.

The module is equipped with a brazed plate heat exchanger and a domestic water priority valve that switches all available heat power to the heat exchanger. The domestic water temperature at usage points is controlled by a thermostatic mixing valve. By virtue of the different use times and the considerable inertia differences, the fast-switching valve does not affect heating side efficiency when DHW production is in operation.

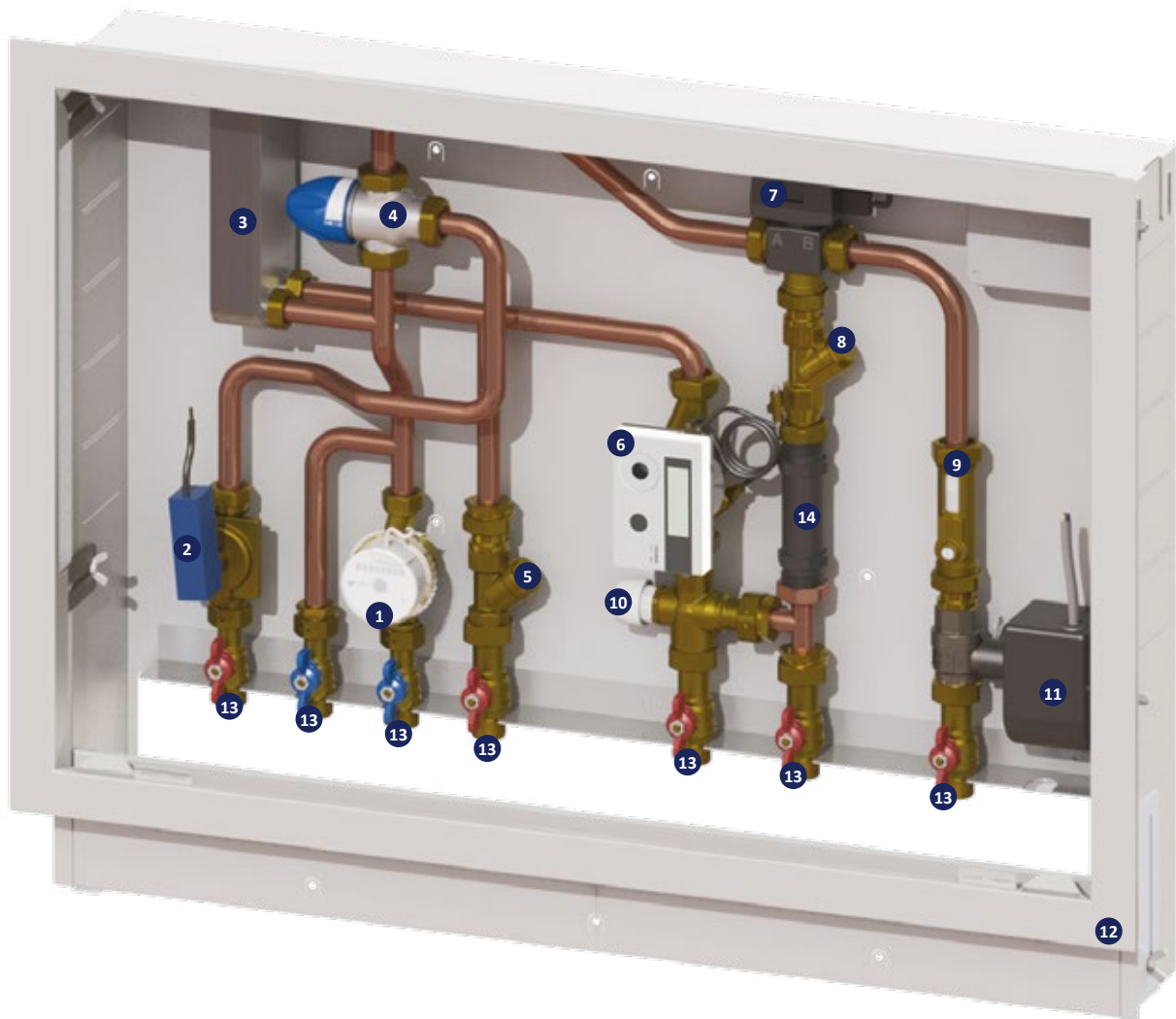

1. Domestic cold water meter
2. Flow switch
3. Heat exchanger
4. Thermostatic mixing valve
5. Impurity-trapping filter
6. Compact thermal energy meter
7. Motorized DHW priority valve
8. Delivery probe holder
9. Flow meter
10. Differential bypass valve
11. Motorized 2/3-way zone valve
12. Metal housing with locking cover and supports
13. Shut-off valves
14. Stub for possible circulating pump installation



10_G HEAT METERING SYSTEM

INSTALLATION COMPONENTS

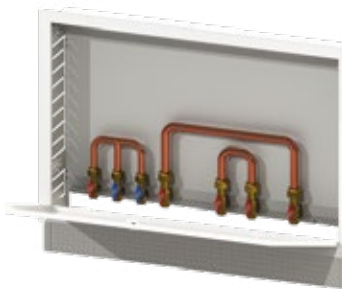

6503C01

Pre-installation metal housing for "HEAT" system. Setup stubs included.

DESCRIPTION

- Galvanized steel housing with painted frame and cover in white RAL 9010
- Dimensions (WxHxD) 850 x 670 x 120 ÷ 170 mm
- Shut-off ball valves for heating/cooling circuit with 3/4" M and 1" F fittings with idle nut
- Shut-off ball valves for domestic water circuits with 3/4" M and 3/4" F fittings with idle nut (with or without built-in non-return valve)
- "Pre-installation" stubs for testing and/or flushing system and subsequent installation of the metering module
- Galvanized steel template for mounting the shut-off valves at the bottom of the housing

Code	Type	Price €	Unit/Box
650 0059	850 x 670 x 120 ÷ 170		1/1



6503G03P

Metering module with instant DHW production consisting of motorized 2-way zone valve, priority valve for domestic water circuit, heat exchanger, thermostatic mixer, compact meter for heating/cooling system and domestic water meter. Local/remote reading. For pre-installation housing art. 6503C01.



DESCRIPTION

- Motorized 2-way zone valve (230 VAC power supply)
- Priority valve for domestic water circuit
- Plate heat exchanger (35 kW or 50 kW)
- Thermostatic anti-scalding mixing valve.
- Differential bypass (0÷400 mbar setting)
- "Y" fitting delivery temperature probe holder with M10x1 fitting
- Balancing valve (8÷30 l/min adjustable range)
- Impurity-removing "Y" filter
- Compact calorie/frigorie meter 130 mm (1") interaxle DN20
Qp = 2.5 m³/h, with electronic unit and 2x probes Ø5 mm
- Meter for domestic cold water circuit, 110 mm interaxle DN15 (3/4")
Q3 = 2.5 m³/h configured with outlet pulse
- Copper fittings for component connection

Code	Exchanger power	Type	Price €	Unit/Box
650 0064	35 kW	M-Bus reading		1/1
650 0065	50 kW	M-Bus reading		1/1
650 0616	35 kW	Wireless reading		1/1
650 0617	50 kW	Wireless reading		1/1

6503C01 + 6503G03P

DIMENSIONAL DIAGRAM FUNCTIONAL DIAGRAM

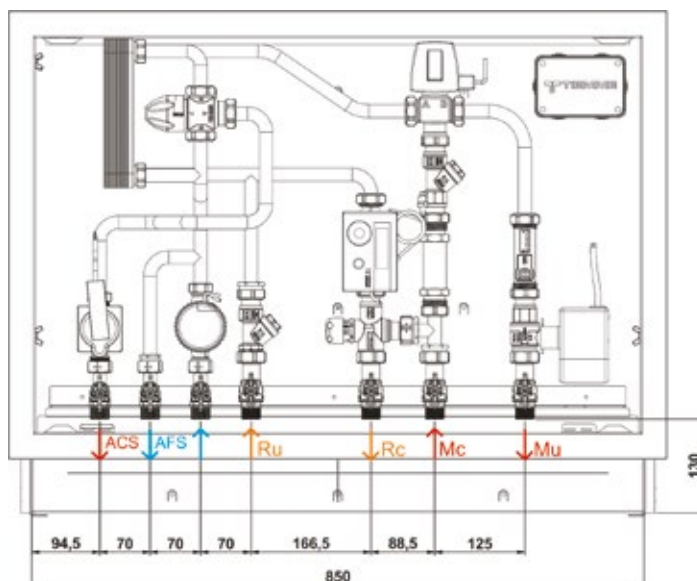

Abbrev.	Description
CHS	Central heating supply
CHR	Central heating return
CS	Consumer supply
CR	Consumer return
DHW	Domestic hot water
DCW	Domestic cold water

Metering module for heating circuits with instant DHW production via steel exchanger and, if equipped, fitting for recirculation. With dynamic balancing valve, pressostatic valve for domestic water priority, zone valve and insulation. It is one of the most widely used systems for metering energy combined with DHW production.

All Heat-EVO modules are insulated and available in 4 versions depending on the configuration:

- **HEAT-EVO1:** Metering module with outlet for low temperature heating (for radiant systems); heating system pump and DHW recirculation pump
- **HEAT-EVO2:** Metering module with outlet for low temperature heating (for radiant systems) and heating system pump
- **HEAT-EVO3:** Metering module with outlet for high temperature heating (for radiators); DHW recirculation pump
- **HEAT-EVO4:** Metering module with outlet for high temperature heating (for radiators)
- **HEAT-EVO1DYN:** Metering module with outlet for low temperature heating (for radiant systems); heating system pump and DHW recirculation pump. Version equipped with balancing valve with differential pressure control on the primary and dynamic balancing on the DHW.

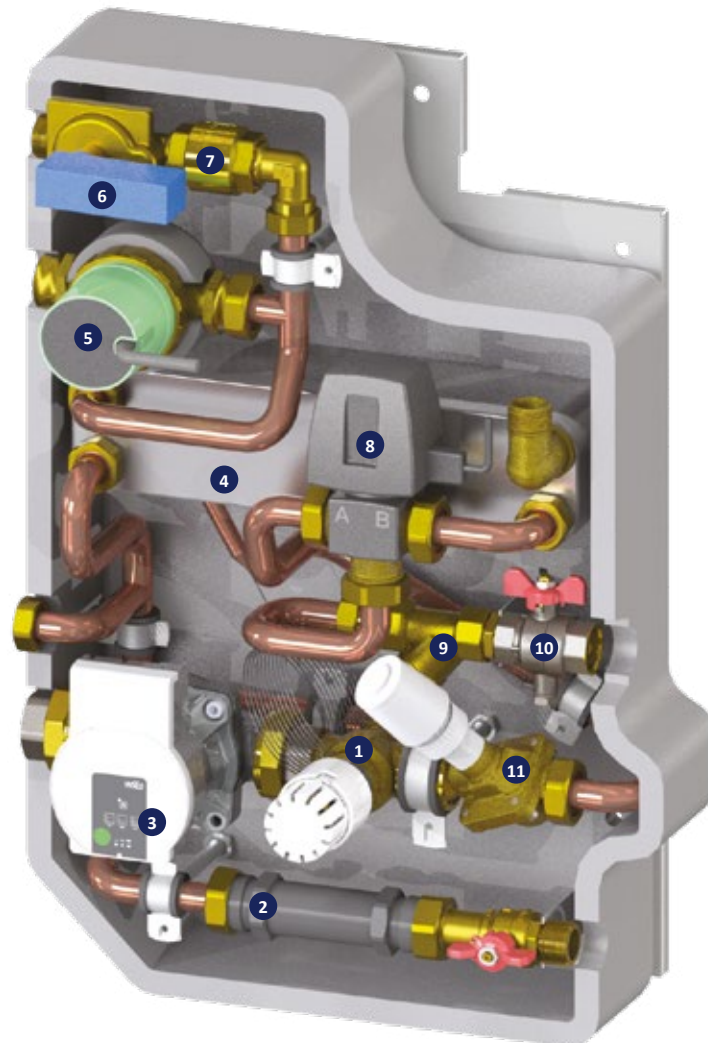

1. Mixing valve
2. Support stub for energy meter installation
3. Heat pump
4. Heat exchanger
5. Recirculation pump
6. Flow switch

7. Non-return valve
8. Diverter valve
9. Impurity-trapping filter
10. Probe holder ball valve
11. Dynamic balancing valve with ON/OFF actuator



10_H HEAT-EVO METERING SYSTEM

INSTALLATION COMPONENTS



HEAT-EVO1

Metering module with outlet for low temperature heating (with mixing) for radiant systems, pump for heating system and pump for DHW recirculation

DESCRIPTION

- Plate heat exchanger 53 kW
- Priority valve for domestic water circuit
- **Domestic recirculation pump**
- Dynamic balancing valve (180÷1080 l/h adjustable range) with Normally Closed actuator with ON/OFF control (230 VAC power supply)
- "Pre-installation" stub for system testing and/or flushing and subsequent installation of the calorie/frigory meter 130 mm (1") interaxis DN20
- Impurity-removing strainer
- Fixed point mixing valve (20÷50 °C setting)
- **Heat pump**
- Copper fittings for component connection
- Insulation shell
- Metal plate for wall mounting

Code	Type	Price €	Unit/Box
650 0636	53 kW		1/1



HEAT-EVO2

Metering module with outlet for low temperature heating (with mixing) for radiant systems and pump for heating system

DESCRIPTION

- Plate heat exchanger 53 kW
- Priority valve for domestic water circuit
- Dynamic balancing valve (180÷1080 l/h adjustable range) with Normally Closed actuator with ON/OFF control (230 VAC power supply)
- "Pre-installation" stub for system testing and/or flushing and subsequent installation of the calorie/frigory meter 130 mm (1") interaxis DN20
- Impurity-removing strainer
- Fixed point mixing valve (20÷50 °C setting)
- **Heat pump**
- Copper fittings for component connection
- Insulation shell
- Metal plate for wall mounting

Code	Type	Price €	Unit/Box
650 0637	53 kW		1/1

HEAT-EVO1 HEAT-EVO2

DIMENSIONAL DIAGRAM FUNCTIONAL DIAGRAM

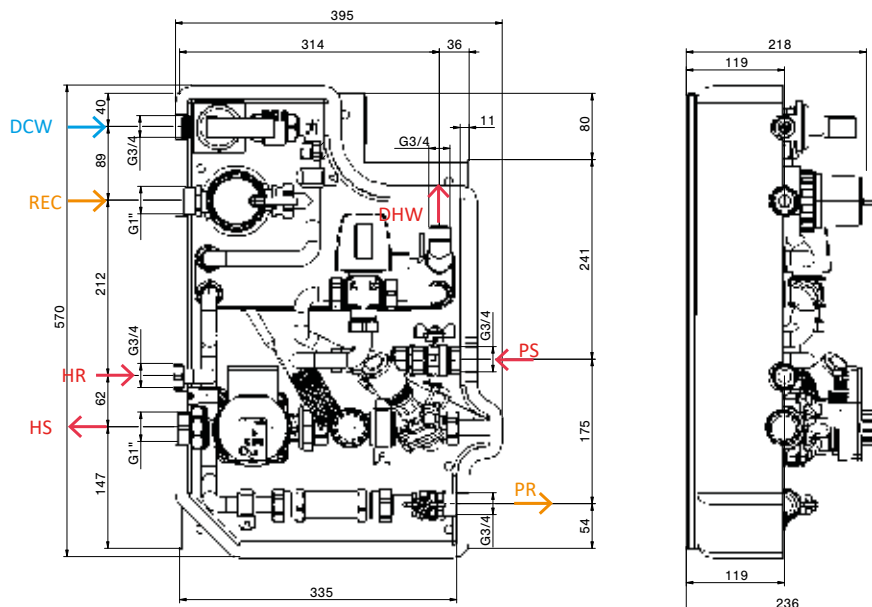

Abbrev.	Description
DHW	Domestic hot water
DCW	Domestic cold water
REC	Recirculation (heat-EVO1 only)
HS	Heating supply

Abbrev.	Description
HR	Heating return
PS	Primary supply
PR	Primary return

10_H HEAT-EVO METERING SYSTEM

INSTALLATION COMPONENTS



HEAT-EVO3
Metering module with outlet for high temperature heating (for radiators) and DHW recirculation pump

DESCRIPTION

- Plate heat exchanger 53 kW
- Priority valve for domestic water circuit
- Domestic water recirculation pump
- Dynamic balancing valve (180÷1080 l/h adjustment) with Normally Closed actuator with ON/OFF control (230 VAC power supply)
- "Pre-installation" stub for system testing and/or flushing and subsequent installation of the calorie/frigory meter 130 mm (1") interaxis DN20
- Impurity-removing strainer
- Copper fittings for component connection
- Insulation shell
- Metal plate for wall mounting

Code	Type	Price €	Unit/Box
650 0638	53 kW		1/1



HEAT-EVO4
Metering module with outlet for high temperature heating (for radiators)

DESCRIPTION

- Plate heat exchanger 53 kW
- Priority valve for domestic water circuit
- Dynamic balancing valve (180÷1080 l/h adjustment) with Normally Closed actuator with ON/OFF control (230 VAC power supply)
- "Pre-installation" stub for system testing and/or flushing and subsequent installation of the calorie/frigory meter 130 mm (1") interaxis DN20
- Impurity-removing strainer
- Copper fittings for component connection
- Insulation shell
- Metal plate for wall mounting

Code	Type	Price €	Unit/Box
650 0639	53 kW		1/1

**HEAT-EVO3
HEAT-EVO4**

**DIMENSIONAL DIAGRAM
FUNCTIONAL DIAGRAM**

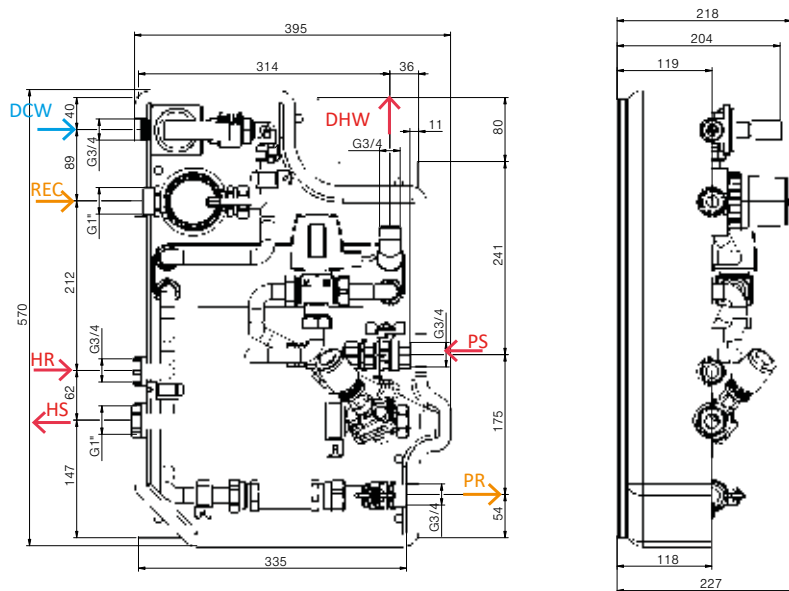

Abbrev.	Description
DHW	Domestic hot water
DCW	Domestic cold water
REC	Recirculation (heat-EVO3 only)
HS	Heating supply

Abbrev.	Description
HR	Heating return
PS	Primary supply
PR	Primary return





6560CW 6560C

Compact single-jet calorie/ frigory meter for local reading, M-Bus remote reading and wireless reading.



TECHNICAL SPECIFICATIONS

- Brass casing with 8-digit LCD display electronic unit, 360° positionable and detachable from main body (cable length 50 cm)
- Communication interfaces: Wireless M-Bus + 3 pulse inlets, M-Bus + 3 pulse inlets, local reading + 3 pulse inlets
- 3V Lithium Battery, 10 years service life (replaceable) - setup for external power supply via 3V power supply
- Pt1000 platinum temperature probes
- Nominal pressure: PN16
- Maximum operating temperature: 90 °C
- Protection rating: IP65
- Certified according to Directive 2014/32/EU (Annex MI-004)

Equipped with 3 pulse inlets

For installation on horizontal or vertical pipes

If used in conjunction with cooled water, the detachable electronics may be attached to the bottom of the housing/shaft in order to avoid possible occurrences of condensation.

Code	Size	Type	Price €	Unit/Box
651 0022	DN20 (1")* Qp = 2.5 m³/h	Local reading		1/6
651 0023	DN20 (1")* Qp = 2.5 m³/h	M-Bus reading		1/6
651 0492	DN20 (1")* Qp = 2.5 m³/h	Wireless reading		1/6

* Size of thread body



6560CUW 6568C

Compact ultrasonic calorie/ frigory meter for local reading, M-Bus remote reading and wireless reading.



TECHNICAL SPECIFICATIONS

- Brass casing with 8-digit LCD display electronic unit, 360° positionable and detachable from main body (cable length 85 cm)
- Communication interfaces: Wireless M-Bus + 3 pulse inlets, M-Bus + 3 pulse inlets, local reading + 3 pulse inlets
- 3V Lithium Battery, 10 years service life (replaceable) - setup for external power supply via 3V power supply
- Pt1000 platinum temperature probes
- Nominal pressure: PN16
- Maximum operating temperature: 90 °C
- Protection rating: IP65
- Certified according to Directive 2014/32/EU (Annex MI-004)

Equipped with 3 pulse inlets

Provides greater durability and accuracy over time, thanks to the absence of moving parts

For installation on horizontal or vertical pipes

If used in conjunction with cooled water, the detachable electronics may be attached to the bottom of the housing/shaft in order to avoid possible occurrences of condensation.

Code	Size	Type	Price €	Unit/Box
651 0601	DN20 (1")* Qp = 2.5 m³/h	Local reading		1/1
651 0056	DN20 (1")* Qp = 2.5 m³/h	M-Bus reading		1/1
651 0494	DN20 (1")* Qp = 2.5 m³/h	Wireless reading		1/6

* Size of thread body



10, TECHNO SEP METERING SYSTEM

INTRODUCTION

Metering module for heating/cooling and domestic water circuits with hydraulic separator **suitable for thermal systems where flow rates and operating temperatures are significantly different**. Set-up for fixed-point or climatic adjustment.

Equipped with a two or three module hydraulic separator able to separate the primary circuit from the secondary circuit. Available in different configurations depending on system requirements. Available for versions which allow for the simultaneous management of high and low temperature is a double circulation pump for secondary branch-off in high temperature and low temperature or with single pump on low temperature with direct high temperature circuit. The secondary branch-off may be managed with thermostatic mixing valve and low temperature recirculation or direct recirculation without mixing.

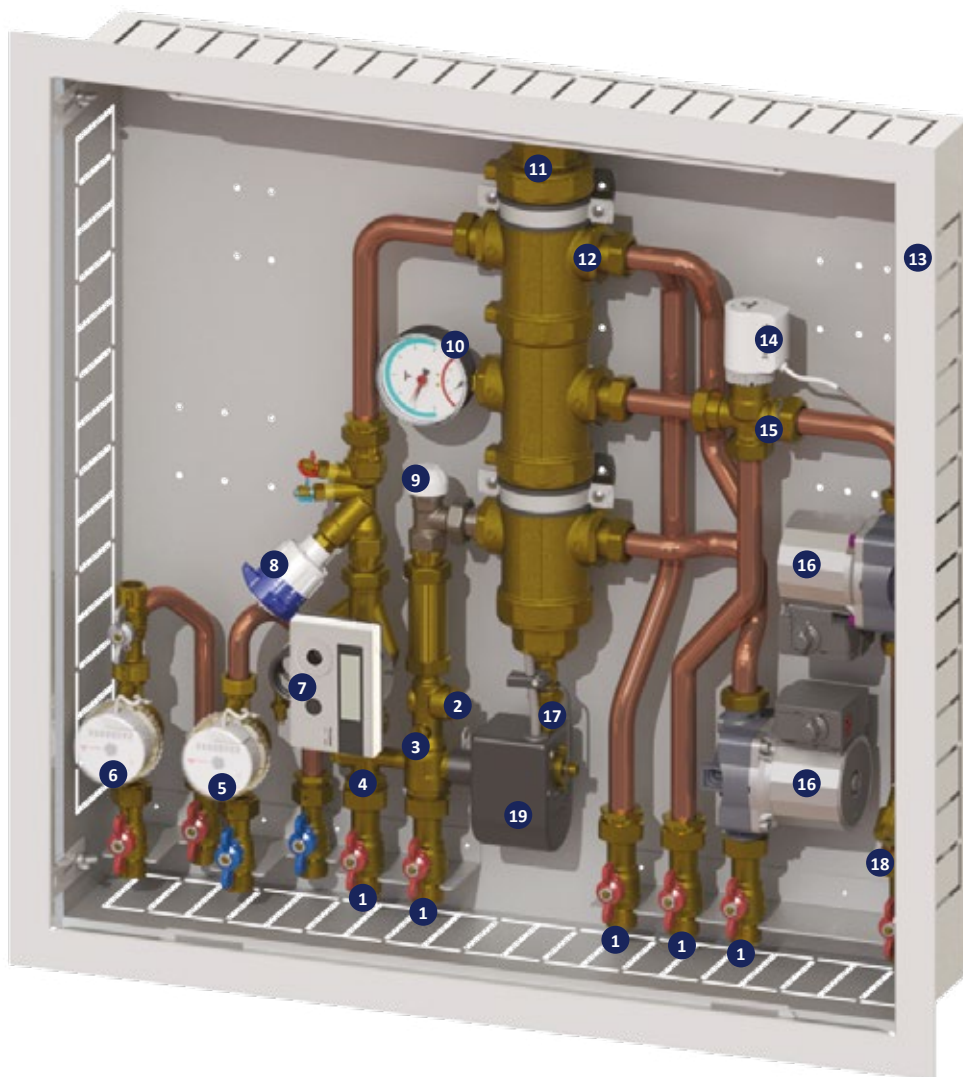

- | | |
|---|---|
| 1. Shut-off valve | 11. Relief valve |
| 2. Dirt collector filter with delivery temperature probe holder | 12. Hydraulic separator |
| 3. Heating-cooling system flow rate control valve | 13. Metal housing with locking cover and supports |
| 4. Control bypass | 14. Actuator |
| 5. Domestic cold water meter | 15. Mixing valve |
| 6. Domestic hot water meter | 16. High efficiency pump |
| 7. Compact thermal energy meter | 17. Load-unload valve |
| 8. Static balancing valve | 18. Probe holder well |
| 9. Lockshield valve | 19. Motorized 3-way zone valve |
| 10. Thermometer manometer | |

10, TECHNO SEP METERING SYSTEM

INSTALLATION COMPONENTS



6506C02

Metering module with three-module separator and low and high temperature distribution. Complete with booster pump for low temperature secondary branch-off and booster pump for high temperature secondary branch-off

DESCRIPTION

- Galvanized steel housing complete with painted frame and cover in white RAL 9010
 - Dimensions (WxHxD) 750 x 750 x 140 ÷ 190 mm
- 3-module hydraulic separator complete with thermomanometer, system load/unload valve and air vent valve
- Ball shut-off valves 3/4" M fittings
- Primary circuit branch-off with 3-way zone valve with motorized adjustable bypass (supply 230 VAC), delivery probe holder well and "pre-installation" stub for testing and/or flushing system and subsequent installation of the calorie/frigory meter 130 mm (1") interaxle DN20, static balancing valve, lockshield valve
- Secondary low temperature distribution circuit branch-off with thermostatic mixing valve and high efficiency circulating pump (EEI <0.23)
- High temperature distribution secondary circuit branch-off high efficiency circulating pump (EEI<0.23)
- Domestic hot and cold water distribution branch-offs with "pre-installation" stubs for system testing and/or flushing and subsequent installation of 110 mm (3/4") interaxle DN15 meters

i Thermostatic/electrothermal control not included

Code	Type	Price €	Unit/Box
650 0373	3M LT-HT		1/1



6506C03

Metering module with two-module separator and low and high temperature distribution. With pump for secondary branch-off in low temperature. Direct high temperature circuit secondary branch-off without circulation pump

DESCRIPTION

- Galvanized steel housing with painted frame and cover in white RAL 9010
 - Dimensions (WxHxD) 750 x 750 x 140 ÷ 190 mm
- 2-module hydraulic separator with system load/unload valve and air vent valve
- Ball shut-off valves 3/4" M fittings
- Primary circuit branch-off with 3-way zone valve with motorized adjustable bypass (supply 230 VAC), delivery probe holder well and "pre-installation" stub for testing and/or flushing system and subsequent installation of the calorie/frigory meter 130 mm (1") interaxle DN20, static balancing valve, lockshield valve
- Secondary low temperature distribution circuit branch-off with thermostatic mixing valve and high efficiency circulating pump (EEI <0.23)
- High temperature distribution secondary circuit branch-off without circulating pump (direct recirculation from central heating system)
- Domestic hot and cold water distribution trunks "pre-installation" for testing and/or flushing system and subsequent installation of 110 mm DN15 (3/4") interaxle counters

i Thermostatic/electrothermal control not included

Code	Type	Price €	Unit/Box
650 0374	2M LT-HT		1/1

6506C02 6506C03

DIMENSIONAL DIAGRAM FUNCTIONAL DIAGRAM

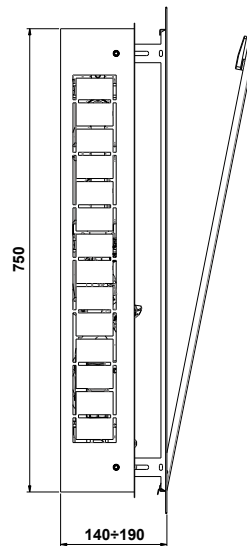
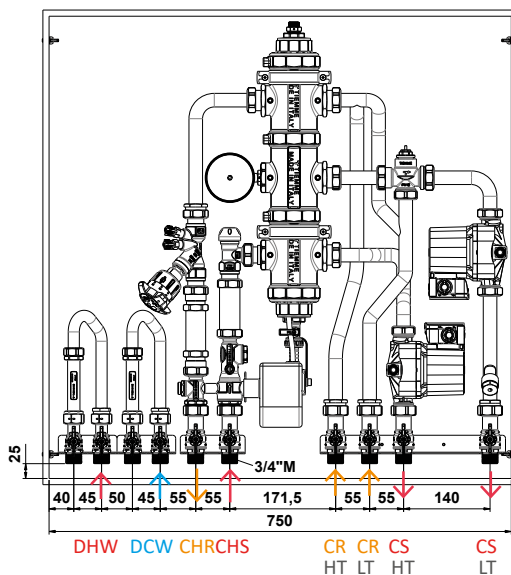

Abbrev.	Description
CHS	Central heating supply
CHR	Central heating return
CS	Consumer supply

Abbrev.	Description
CR	Consumer return
DHW	Domestic hot water
DCW	Domestic cold water

Abbrev.	Description
LT	Low temperature
HT	High temperature



10, TECHNO SEP METERING SYSTEM

INSTALLATION COMPONENTS



6506C04

Metering module with two-module separator and low temperature distribution. With thermostatic mixing valve and secondary booster pump

DESCRIPTION

- Galvanized steel housing with painted frame and cover in white RAL 9010
 - Dimensions (WxHxD) 750 x 750 x 140 ÷ 190 mm
- 2-module hydraulic separator with system load/unload valve and air vent valve
- Ball shut-off valves 3/4" M fittings
- Primary circuit branch-off with 3-way zone valve with motorized adjustable bypass (power supply 230 VAC), delivery probe holder well and "pre-installation" stub for testing and/or flushing system and subsequent installation of the calorie/frigory meter 130 mm (1") interaxle DN20, static balancing valve, lockshield valve
- Secondary low temperature distribution circuit branch-off with thermostatic mixing valve and high efficiency circulating pump (EEI <0.23)
- Domestic hot and cold water distribution branch-offs with "pre-installation" stubs for system testing and/or flushing and subsequent installation of 110 mm (3/4") interaxle DN15 meters

 Thermostatic/electrothermal control not included

Code	Type	Price €	Unit/Box
650 0375	2M LT		1/1



6506C05

Metering module with two-module separator and low or high temperature distribution. Without secondary mixing. With secondary circuit pump

DESCRIPTION

- Galvanized steel housing with painted frame and cover in white RAL 9010
 - Dimensions (WxHxD) 750 x 750 x 140 ÷ 190 mm
- 2-module hydraulic separator with system load/unload valve and air vent valve
- Ball shut-off valves 3/4" M fittings
- Primary circuit branch-off, with 3-way zone valve with motorized adjustable bypass (230 VAC supply), delivery probe holder well and "pre-installation" stub for testing and/or flushing and subsequent installation of the calorie/frigory meter 130 mm interaxle DN20 (1"), static balancing valve, lockshield valve.
- Secondary distribution circuit in low or high temperature branch-off with high efficiency circulating pump (EEI <0.23)
- Domestic hot and cold water distribution branch-offs with "pre-installation" stubs for system testing and/or flushing and subsequent installation of 110 mm (3/4") interaxle DN15 meters

Code	Type	Price €	Unit/Box
650 0376	2M LT OR HT		1/1

6506C04 6506C05

DIMENSIONAL DIAGRAM FUNCTIONAL DIAGRAM

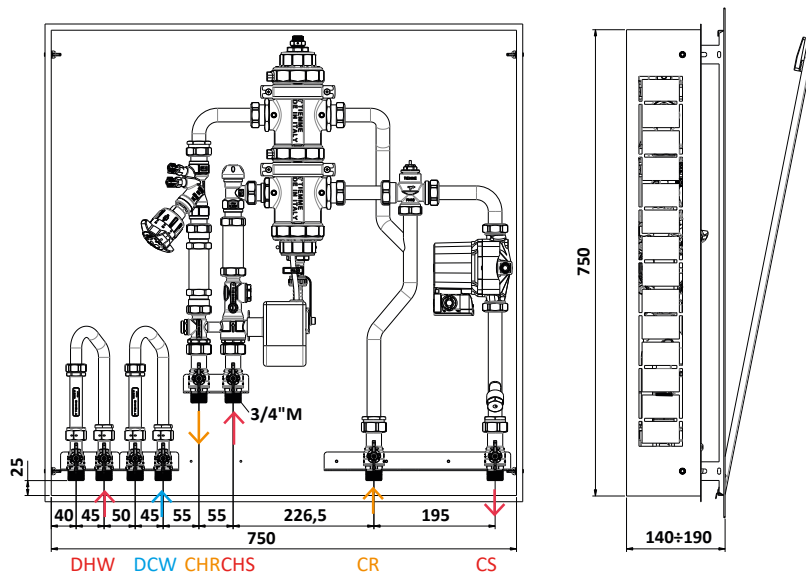

Abbrev.	Description	Abbrev.	Description
CHS	Central heating supply	CR	Consumer return
CHR	Central heating return	DHW	Domestic hot water
CS	Consumer supply	DCW	Domestic cold water



6560CW 6560C

Compact single-jet calorimeter/energy meter for local reading, M-Bus remote reading and wireless reading.



TECHNICAL SPECIFICATIONS

- Brass casing with 8-digit LCD display electronic unit, 360° positionable and detachable from main body (cable length 50 cm)
- Communication interfaces: Wireless M-Bus + 3 pulse inlets, M-Bus + 3 pulse inlets, local reading + 3 pulse inlets
- 3V Lithium Battery, 10 years service life (replaceable) - setup for external power supply via 3V power supply
- Pt1000 platinum temperature probes
- Nominal pressure: PN16
- Maximum operating temperature: 90 °C
- Protection rating: IP65
- Certified according to Directive 2014/32/EU (Annex MI-004)

Equipped with 3 pulse inlets

For installation on horizontal or vertical pipes

If used in conjunction with cooled water, the detachable electronics may be attached to the bottom of the housing/shaft in order to avoid possible occurrences of condensation.

Code	Size	Type	Price €	Unit/Box
651 0022	DN20 (1")* Qp = 2.5 m³/h	Local reading		1/6
651 0023	DN20 (1")* Qp = 2.5 m³/h	M-Bus reading		1/6
651 0492	DN20 (1")* qp = 2,5 m³/h	Wireless reading		1/6

* Size of thread body



6560CUW 6568C

Compact ultrasonic calorimeter/energy meter for local reading, M-Bus remote reading and wireless reading.



TECHNICAL SPECIFICATIONS

- Brass casing with 8-digit LCD display electronic unit, 360° positionable and detachable from main body (cable length 85 cm)
- Communication interfaces: Wireless M-Bus + 3 pulse inlets, M-Bus + 3 pulse inlets, local reading + 3 pulse inlets
- 3V Lithium Battery, 10 years service life (replaceable) - setup for external power supply via 3V power supply
- Pt1000 platinum temperature probes
- Nominal pressure: PN16
- Maximum operating temperature: 90 °C
- Protection rating: IP65
- Certified according to Directive 2014/32/EU (Annex MI-004)

Equipped with 3 pulse inlets

Ensures greater durability and accuracy over time, thanks to the absence of moving parts

For installation on horizontal or vertical pipes

If used in conjunction with cooled water, the detachable electronics may be attached to the bottom of the housing/shaft in order to avoid possible occurrences of condensation.

Code	Size	Type	Price €	Unit/Box
651 0601	DN20 (1")* Qp = 2.5 m³/h	Local reading		1/1
651 0056	DN20 (1")* Qp = 2.5 m³/h	M-Bus reading		1/1
651 0494	DN20 (1")* Qp = 2.5 m³/h	Wireless reading		1/6

* Size of thread body





6561C

Single-jet meter for hot or cold water with local or remote M-Bus reading



TECHNICAL SPECIFICATIONS

- Brass casing with direct reading on 8 numbered rollers: 5 (black) for cubic metres – 3 (red) for sub-multiples
- Maximum operating temperature:
 - 50 °C (domestic cold water model)
 - 90 °C (domestic hot water model)
- Nominal pressure (PN) 16 bar
- Certified according to Directive 2014/32/EU (Annex MI-001)

i For installation on horizontal or vertical pipes

i Configured for remote reading if combined with art. 6561E

Code	Size	Type	Price €	Unit/Box
651 0024	DN15 (3/4")* Q3 = 2.5 m ³ /h	domestic cold water		1/12
651 0026	DN15 (3/4")* Q3 = 2.5 m ³ /h	domestic hot water		1/12

* Size of thread body



6561E

Pulse emitter cable. 1/10 pulse/litre



TECHNICAL SPECIFICATIONS

- Cable length: 1 m

Code	Type	Price €	Unit/Box
651 0085	For 6561C		1/10



6561CR 6561HR

Single-jet meter for hot or cold water with local or wireless remote reading



TECHNICAL SPECIFICATIONS

- Brass casing with direct reading on 8 numbered rollers: 5 (black) for cubic metres – 3 (red) for sub-multiples
- Maximum operating temperature:
 - 50 °C (domestic cold water model)
 - 90 °C (domestic hot water model)
- Nominal pressure (PN) 16 bar
- Approved in accordance with Directive 2014/32/EU (Annex MI-001)

i For installation on horizontal or vertical pipes

i Configured for wireless data transmission when combined with art. 6561MR

Code	Size	Type	Price €	Unit/Box
651 0484	DN15 (3/4")* Q3 = 2.5 m ³ /h	domestic cold water		1/12
651 0514	DN15 (3/4")* Q3 = 2.5 m ³ /h	domestic hot water		1/12

* Size of thread body



6561MR

Compact radio module with integrated 868 MHz inductive wireless sensor WIRELESS M-Bus



TECHNICAL SPECIFICATIONS

- Power supply: lithium battery, service life 11+1 years
- Protection rating: IP67

Code	Type	Price €	Unit/Box
651 0486	For 6561CR - 6561HR		1/40



9561TT
Kit for adjustable fixed point adjustment 20+50°C.

Code	Type	Price €	Unit/Box
040 0179	Fixed point		1/1



5530P
NTC temperature probe 10KΩ @ 25°C, diameter 6 mm

Code	Type	Price €	Unit/Box
555 0149	-		1/10



9562
Electrothermal servocontrol for 3-way mixing valve.

Code	Type	Price €	Unit/Box
450 0383	24 VAC 0±10 VDC		1/10



6506I3M
Thermoformed thermal insulation for "TECHNO SEP" metering module with 3-module hydraulic separator

DESCRIPTION
• Insulation shell material: PEX closed cell foam

Code	Type	Price €	Unit/Box
650 0419	6506C02		1/1



6506I2M
Thermoformed thermal insulation for "TECHNO SEP" metering module with 2-module hydraulic separator

DESCRIPTION
• Insulating shell material: PEX closed cell foam

Code	Type	Price €	Unit/Box
650 0414	6506C03, 6506C04, 6506C05		1/1



2075
Adjustable touch thermostat

TECHNICAL SPECIFICATIONS
• Adjustment range: 0-90°C
• Outlet: Voltage-free changeover contacts 16(4) TO/250 VAC-6(1) TO/400 VAC
• Protection rating IP40
• Differential: 6 ± 2°C
• Fastening spring included

Code	Type	Price €	Unit/Box
957 0001	0/90°C		1/20



11

DIRECT METERING METERS

11A Meters - introduction

232

11B Thermal energy meters



233

11C Domestic water meters



233

11A METERS - INTRODUCTION

Meters are instruments used to measure thermal energy and domestic water usage.

The particularly wide range permits their application both in domestic-type systems and in industrial-type systems.

Available in local reading, M-Bus or wireless versions.

M-Bus-enabled meters allow the transfer of tracking data to a data concentrator.

The wireless version means the transfer of data to a radio device at 868 MHz, in line with WIRELESS M-Bus (EN 13757) standards and with the benefit of installation and remote reading even in existing buildings without the need for costly masonry work.

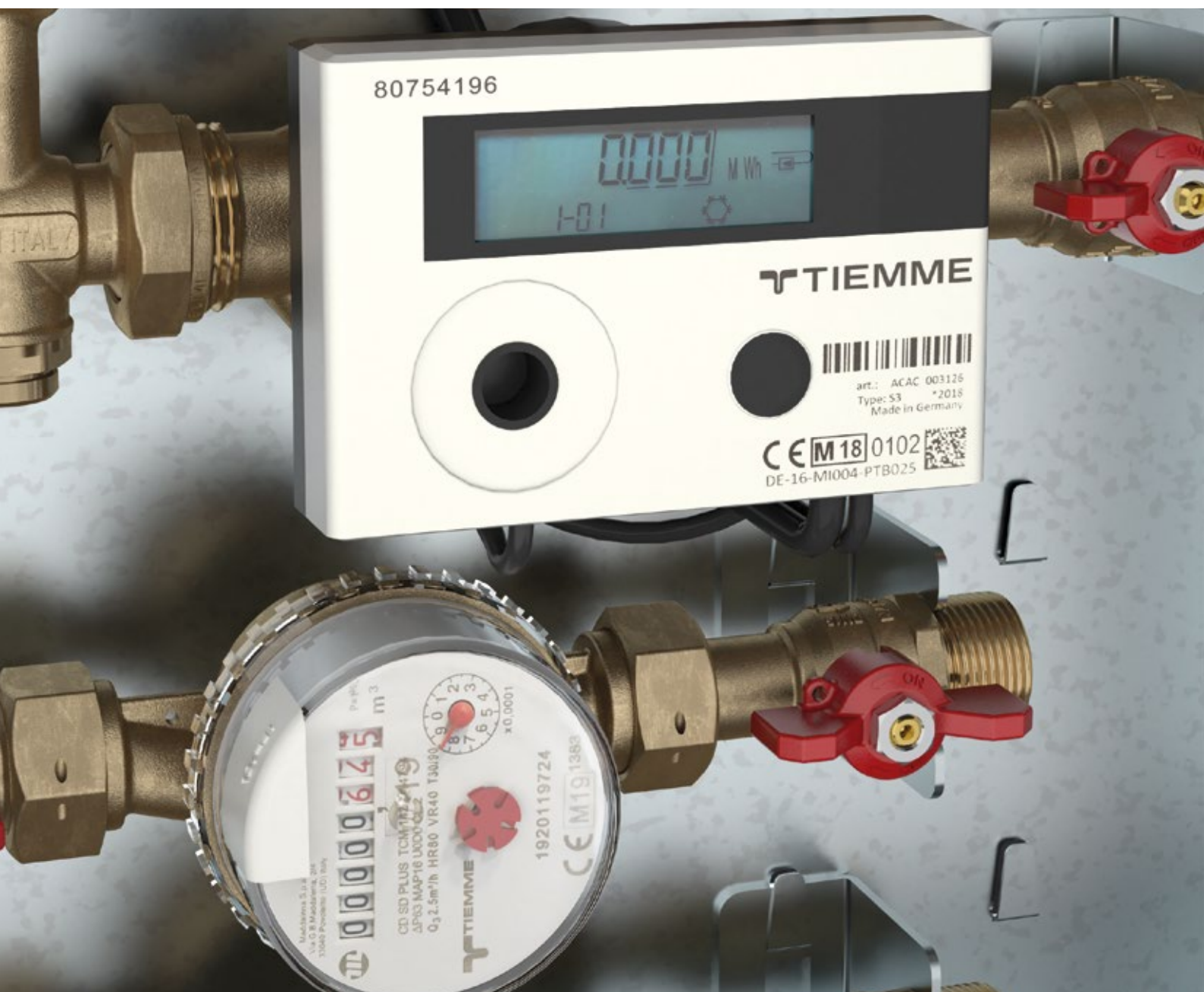

11_B THERMAL ENERGY METERS

COMPACT SINGLE-JET MECHANICAL METER



6560CW 6560C

Compact single-jet calorie/frigory meter for local reading, M-Bus remote reading and wireless reading.



TECHNICAL SPECIFICATIONS

- Brass casing with 8-digit LCD display electronic unit, 360° positionable and detachable from main body (cable length 50 cm)
- Communication interfaces: Wireless M-Bus + 3 pulse inlets, M-Bus + 3 pulse inlets, local reading + 3 pulse inlets
- 3V Lithium Battery, 10 years service life (replaceable) - setup for external power supply via 3V power supply
- Pt1000 platinum temperature probes
- Nominal pressure: PN16
- Maximum operating temperature: 90 °C
- Protection rating: IP65
- Certified according to Directive 2014/32/EU (Annex MI-004)

Equipped with 3 pulse inlets

For installation on horizontal or vertical pipes

If used in conjunction with cooled water, the detachable electronics may be attached to the bottom of the housing/shaft in order to avoid possible occurrences of condensation.

To be combined with:
• Probe holder well "wet" mounted (art.3670PS).

Code	Size	Type	Price €	Unit/Box
651 0020	DN15 (3/4")* Qp = 1.5 m³/h	Local reading		1/6
651 0021	DN15 (3/4")* Qp = 1.5 m³/h	M-Bus reading		1/6
651 0491	DN15 (3/4")* Qp = 1.5 m³/h	Wireless reading		1/6
651 0022	DN20 (1")* Qp = 2.5 m³/h	Local reading		1/6
651 0023	DN20 (1")* Qp = 2.5 m³/h	M-Bus reading		1/6
651 0492	DN20 (1")* Qp = 2.5 m³/h	Wireless reading		1/6

* Size of thread body

COMPACT ULTRASONIC METER



6560CUW 6568C

Compact ultrasonic calorie/frigory meter for local reading, M-Bus remote reading and wireless reading.



TECHNICAL SPECIFICATIONS

- Brass casing with 8-digit LCD display electronic unit, 360° positionable and detachable from main body (cable length 85 cm)
- Communication interfaces: Wireless M-Bus + 3 pulse inlets, M-Bus + 3 pulse inlets, local reading + 3 pulse inlets
- 3V Lithium Battery, 10 years service life (replaceable) - setup for external power supply via 3V power supply
- Pt1000 platinum temperature probes
- Nominal pressure: PN16
- Maximum operating temperature: 90 °C
- Protection rating: IP65
- Certified according to Directive 2014/32/EU (Annex MI-004)

Equipped with 3 pulse inlets

Provides greater durability and accuracy over time, thanks to the absence of moving parts

For installation on horizontal or vertical pipes

If used in conjunction with cooled water, the detachable electronics may be attached to the bottom of the housing/shaft in order to avoid possible occurrences of condensation.

To be combined with:
• Probe holder well "wet" mounted (art.3670PS).

Code	Size	Type	Price €	Unit/Box
651 0600	DN15 (3/4")* Qp = 1.5 m³/h	Local reading		1/1
651 0055	DN15 (3/4")* Qp = 1.5 m³/h	M-Bus reading		1/1
651 0493	DN15 (3/4")* Qp = 1.5 m³/h	Wireless reading		1/6
651 0601	DN20 (1")* Qp = 2.5 m³/h	Local reading		1/1
651 0056	DN20 (1")* Qp = 2.5 m³/h	M-Bus reading		1/1
651 0494	DN20 (1")* Qp = 2.5 m³/h	Wireless reading		1/6

* Size of thread body

11_B THERMAL ENERGY METERS

HIGH FLOW RATE METERS - SEPARATE ELECTRONICS



6562T

Multiple-jet, super dry, magnetic transmission meter, pulse outlet 1/10 imp/l.



M-Bus
OPTIONAL

M-Bus
Wireless
OPTIONAL

TECHNICAL SPECIFICATIONS

- Brass casing
- Protective metal cap
- Rotatable totalizer for ease of reading
- Inlet filter
- Equipped with reed switch pulse emitter
- Maximum operating temperature: 90 °C
- Nominal pressure: PN16
- Certified according to Directive 2014/32/EU (Annex MI-004)

i For installation on horizontal pipes

To be combined with:

- Separate electronics for local reading, M-Bus or wireless (art. 6564C)
- Pair of temperature probes PT500 for "dry" mounting (art.6565SA) or "wet" mounting (art.6565SB) and corresponding pair of probe holder wells "dry" mount (art.6567C) o "wet" mount (art.3670PS).

Code	Size	Pulse outlet	Price €	Unit/ Box
651 0488	DN25 (1"1/4)* Qp = 3.5 m³/h	1/10 imp/l		1/2
651 0502	DN32 (1"1/2)* Qp = 6 m³/h	1/10 imp/l		1/2
651 0503	DN40 (2")* Qp = 10 m³/h	1/10 imp/l		1/2
651 0504	DN50 (2" 3/8)* Qp = 15 m³/h	1/10 imp/l		1/1

* Size of thread body



6563CC130

Woltmann flanged series thermal energy meter.



M-Bus
OPTIONAL

M-Bus
Wireless
OPTIONAL

TECHNICAL SPECIFICATIONS

- Cast iron casing, internally and externally powder coated
- Hermetically-sealed clockwork (IP68) and fully 360 degrees rotatable
- Removable measuring element
- Supplied with reed switch pulse emitter (IP66 and 3 m cable)
- Reed switch electrical features: max. 24 V, 0.2 A, max. 4W
- Maximum operating temperature 130/120 °C
- Nominal pressure: PN16
- Certified according to Directive 2014/32/EU (Annex MI-004)

i For installation on horizontal or vertical pipes

To be combined with:

- Separate electronics for local reading, M-Bus or wireless (art. 6564C)
- Pair of temperature probes PT500 for "dry" mounting (art.6565SA) and corresponding pair of probe holder wells "dry" mount (art.6567C)

Code	Size	Pulse outlet	Price €	Unit/ Box
651 0509	DN50 Qp = 15 m³/h	1/100 imp/l		1/1
651 0510	DN65 Qp = 25 m³/h	1/100 imp/l		1/1
651 0511	DN80 Qp = 40 m³/h	1/100 imp/l		1/1
651 0512	DN100 Qp = 60 m³/h	1/100 imp/l		1/1
651 0643	DN125 Qp = 100 m³/h	1/100 imp/l		1/1
651 0644	DN150 Qp = 150 m³/h	1/1000 imp/l		1/1
651 0645	DN200 Qp = 200 m³/h	1/1000 imp/l		1/1



11_B THERMAL ENERGY METERS

ULTRASONIC HIGH FLOW RATE METERS - SEPARATE ELECTRONICS



6569CW

Ultrasonic thermal energy meter with flanged fittings PN25. Suitable for industrial installation



TECHNICAL SPECIFICATIONS

- Maximum operating temperature 130 °C
- Nominal pressure: PN25
- With electronics - cable length 2m
- Battery powered, service life 10 years
- Protection rating IP65

+ Provides greater durability and accuracy over time, thanks to the absence of moving parts

i For installation on horizontal or vertical pipes

To be combined with:

- Separate electronics for local reading, M-Bus or wireless (art. 6564C)
- Pair of temperature probes PT500 for "dry" mounting (art.6565SA) or "wet" mounting (art.6565SB) and corresponding pair of probe holder wells "dry" mount (art.6567C) o "wet" mount (art.3670PS).

Code	Size	Pulse outlet	Price €	Unit/Box
651 0496	DN25 Qp = 6 m ³ /h	1/10 imp/l		1/1
651 0497	DN40 Qp = 10 m ³ /h	1/10 imp/l		1/1
651 0498	DN50 Qp = 15 m ³ /h	1/25 imp/l		1/1
651 0499	DN65 Qp = 25 m ³ /h	1/25 imp/l		1/1
651 0500	DN80 Qp = 40 m ³ /h	1/100 imp/l		1/1
651 0501	DN100 Qp = 60 m ³ /h	1/100 imp/l		1/1



6564C

Separate electronic unit for combined heat energy meters.



TECHNICAL SPECIFICATIONS

- Calorie and frigory measurement
- 3V replaceable lithium battery, 10 year service life
- Communication interfaces: Wireless M-Bus + 3 pulse inlets, M-Bus + 3 pulse inlets, volume and energy pulse outlet, calorie and frigory pulse outlet
- IP65 rating
- Settable annual reading date, 15 monthly values viewable on display, 24 monthly values viewable via optical interface or M-Bus
- Dimensions (WxHxD): 150 x 130 x 35 mm

i Programmable pulse factor: to be programmed before installation according to the combined meter pulse features

Code	Type	Price €	Unit/Box
651 0642	Local reading, programmable		1/4
651 0046	M-Bus reading, programmable		1/4
6510495	Wireless reading, programmable		1/4



6565SA

Temperature probe pair PT500 (EN 60751) for wells 6567C ("dry" mounting).

Code	Type	Price €	Unit/Box
651 0050	∅ 6 mm - 3 m		1/10
651 0615	∅ 6 mm - 10 m		1/5



6567C

Pair of probe holder wells ("dry" mounting)

Code	Type	Price €	Unit/Box
651 0052	DN32-DN65		1/100
651 0053	DN80-DN125		1/50
651 0054	DN150-DN200		1/10



6565SB

Temperature probe pair PT500 (EN 60751) for wells art. 3670PS ("wet" mounting).

Code	Type	Price €	Unit/Box
651 0049	∅ 5 mm - 3 m		1/10
651 0450	∅ 5 mm - 10 m		1/5



3670PS

Fitting with M10x1 fitting for temperature probe ("wet" mounting).

Code	Type	Price €	Unit/Box
651 0015	3/4"		18/54
651 0016	1"		10/30
651 0017	1"1/4		4/16



1522

Union kit

i The kit includes: 2 tails, 2 nuts and 2 gaskets

Code	∅ Meter	∅ Fitting	Price €	Unit/Box
150 0035	3/4" F	1/2" M		1/80
150 0042	1" F	3/4" M		1/40
150 0062	1"1/4 F	1" M		1/20
150 0094	1"1/2 F	1"1/4 M		1/15
150 0072	2" F	1"1/2 M		1/10
150 0914	2"3/8 F	2" M		1/5
150 0101	2"1/2 F	2" M		1/5



6561TUSB

USB optical head for programming or parameter modification on heat cost allocators and meters.

i It also includes pairing to programming software for installation on PC. For more information contact the Tiemme Systems Department.

Code	Type	Price €	Unit/Box
651 0051	for 6560CW- 6560C - 6560CUW - 6568C		1/10



11c DOMESTIC WATER METERS

LOCAL READING/M-BUS VOLUMETRIC METER



6561C

Single-jet meter for hot or cold water with local or remote M-Bus reading



TECHNICAL SPECIFICATIONS

- Brass casing with direct reading on 8 numbered rollers: 5 (black) for cubic meters – 3 (red) for sub-multiples
- Maximum operating temperature:
 - 50 °C (domestic cold water model)
 - 90 °C (domestic hot water model)
- Nominal pressure (PN) 16 bar
- Certified according to Directive 2014/32/EU (Annex MI-001)

i For installation on horizontal or vertical pipes

i Configured for remote reading if combined with art. 6561E

Code	Size	Type	Price €	Unit/Box
651 0024	DN15 (3/4")* Q3 = 2.5 m ³ /h	domestic cold water		1/12
651 0026	DN15 (3/4")* Q3 = 2.5 m ³ /h	domestic hot water		1/12
651 0028	DN20 (1")* Q3 = 4 m ³ /h	domestic cold water		1/12
651 0030	DN20 (1")* Q3 = 4 m ³ /h	domestic hot water		1/12

* Size of thread body

ACCESSORIES AND SPARE PARTS



6561E

Pulse emitter cable. 1/10 pulse/liter.



TECHNICAL SPECIFICATIONS

- Cable length: 1 m

Code	Type	Price €	Unit/Box
651 0085	For 6561C		1/10

LOCAL READING/M-BUS VOLUMETRIC METER



6561CR 6561HR

Single-jet meter for hot or cold water with local or wireless remote reading



TECHNICAL SPECIFICATIONS

- Brass casing with direct reading on 8 numbered rollers: 5 (black) for cubic meters – 3 (red) for sub-multiples
- Maximum operating temperature:
 - 50 °C (domestic cold water model)
 - 90 °C (domestic hot water model)
- Nominal pressure (PN) 16 bar
- Approved in accordance with Directive 2014/32/EU (MID MI-001)

i For installation on horizontal or vertical pipes

i Configured for wireless data transmission when combined with art. 6561MR

Code	Size	Type	Price €	Unit/Box
651 0484	DN15 (3/4")* Q3 = 2.5 m ³ /h	domestic cold water		1/12
651 0514	DN15 (3/4")* Q3 = 2.5 m ³ /h	domestic hot water		1/12
651 0513	DN20 (1")* Q3 = 4 m ³ /h	domestic cold water		1/12
651 0515	DN20 (1")* Q3 = 4 m ³ /h	domestic hot water		1/12

* Size of thread body

ACCESSORIES AND SPARE PARTS



6561MR

Compact radio module with integrated 868 MHz WIRELESS M-Bus inductive wireless sensor.



TECHNICAL SPECIFICATIONS

- Power supply: lithium battery, service life 11+1 years
- Protection rating: IP67

Code	Type	Price €	Unit/Box
651 0486	For 6561CR - 6561HR		1/40



6561MM

Compact M-BUS module



TECHNICAL SPECIFICATIONS

- Power supply: lithium battery, service life up to 12 years (with power supply M-Bus)
- Protection rating: IP68

+ Directly connectible to the M-Bus network

Code	Type	Price €	Unit/Box
651 0934	For 6561CR - 6561HR		1/50

11c DOMESTIC WATER METERS

HIGH FLOW RATE DOMESTIC COLD WATER VOLUMETRIC METER



6561D

Local reading multiple-jet meter for domestic cold water for high flow rate equipped with pulse emitter 1/10 pul/l for M-Bus remote reading



TECHNICAL SPECIFICATIONS

- Brass casing
- Equipped with pulse emitter cable (pulse emitter type: reed - switch - Pulse factor: 1 pulse every 10 liters)
- Rotatable totalizer for ease of reading
- Inlet filter
- Maximum operating temperature: 50 °C
- Nominal pressure: PN16
- Certified according to Directive 2014/32/EU (Annex MI-001)

i For installation on horizontal pipes

i Configured for wireless data transmission when combined with art. 6583MR

Code	Size	Pulse outlet	Price €	Unit/Box
651 0516	DN25 (1" 1/4)* Q3 = 6.3 m³/h	1/10 imp/l		1/2
651 0517	DN32 (1" 1/2)* Q3 = 10 m³/h	1/10 imp/l		1/2
651 0518	DN40 (2")* Q3 = 16 m³/h	1/10 imp/l		1/2
651 0519	DN50 (2" 1/2)* Q3 = 25 m³/h	1/10 imp/l		1/2

* Size of thread body

ACCESSORIES AND SPARE PARTS



6583MR

Wireless M-bus module.



TECHNICAL SPECIFICATIONS

- Frequency: 868/915 MHz
- Mode of data transmission: T1 (EN 13757)
- Management: inlet pulses, direction signals and alarms (handling, removal or presumed leaking)
- Configuration: via radio
- Power supply: lithium battery 3 V, service life 12 years
- Protection rating: IP68

Code	Type	Price €	Unit/Box
651 0532	for 6561D - 6562D - 6563CF		1/60

HIGH FLOW RATE DOMESTIC COLD WATER VOLUMETRIC METER



6562D

Local reading multiple-jet meter for domestic cold water for high flow rate equipped with pulse emitter 1/10 pul/l for M-Bus remote reading



TECHNICAL SPECIFICATIONS

- Brass casing
- Equipped with pulse emitter cable (pulse emitter type: reed - switch - Pulse factor: 1 pulse every 10 liters)
- Rotatable totalizer for ease of reading
- Inlet filter
- Maximum operating temperature: 90 °C
- Nominal pressure: PN16
- Certified according to Directive 2014/32/EU (Annex MI-001)

i For installation on horizontal pipes

i Configured for wireless data transmission when combined with art. 6583MR

Code	Size	Pulse outlet	Price €	Unit/Box
651 0520	DN25 (1" 1/4)* Q3 = 6.3 m³/h	1/10 imp/l		1/2
651 0521	DN32 (1" 1/2)* Q3 = 10 m³/h	1/10 imp/l		1/1
651 0522	DN40 (2")* Q3 = 16 m³/h	1/10 imp/l		1/1
651 0523	DN50 (2" 1/2)* Q3 = 25 m³/h	1/10 imp/l		1/1

* Size of thread body

ACCESSORIES AND SPARE PARTS



6583MR

Wireless M-bus module.



TECHNICAL SPECIFICATIONS

- Frequency: 868/915 MHz
- Mode of data transmission: T1 (EN 13757)
- Management: inlet pulses, direction signals and alarms (handling, removal or presumed leaking)
- Configuration: via radio
- Power supply: lithium battery 3 V, service life 12 years
- Protection rating: IP68

Code	Type	Price €	Unit/Box
651 0532	for 6561D - 6562D - 6563CF		1/60



11c DOMESTIC WATER METERS

WOLTMANN FLANGED SERIES DOMESTIC COLD WATER METER



6563CF

Woltmann axial volumetric meter for domestic cold water up to 50° C flanged.



TECHNICAL SPECIFICATIONS

- Cast iron casing
- Clockwork with glass disc and copper capsule (IP68)
- Maximum operating temperature: 50 °C
- Nominal pressure: PN16
- Certified according to Directive 2014/32/EU (Annex MI-001)

i For installation on horizontal or vertical pipes

i Configured for remote reading if combined with art. 6583S

i Configured for wireless data transmission when combined with art. 6583S + art. 6583MR

Code	Size	Price €	Unit/Box
651 0524	DN50 Q3 = 40 m³/h		1/1
651 0525	DN65 Q3 = 63 m³/h		1/1
651 0526	DN80 Q3 = 100 m³/h		1/1
651 0527	DN100 Q3 = 160 m³/h		1/1

ACCESSORIES AND SPARE PARTS

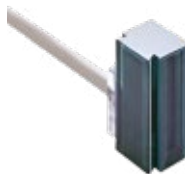

6583S

Reed sensor for Woltmann meters.

1/100 pulse/liter.



TECHNICAL SPECIFICATIONS

- Contact type: reed switch (normally closed)
- Maximum permissible load 24 VAC - 0.1 A
- Protection rating: IP68
- Cable type: 2 x 0.25 mm²
- Cable length: 2 m
- Operating temperature: -25 °C ÷ +90 °C
- Storage temperature: -40 °C ÷ +90 °C

Code	Type	Price €	Unit/Box
651 0533	For 6563CF		1/40



6583MR

Wireless M-bus module.



TECHNICAL SPECIFICATIONS

- Frequency: 868/915 MHz
- Mode of data transmission: T1 (EN 13757)
- Management: inlet pulses, direction signals and alarms (handling, removal or presumed leaking)
- Configuration: via radio
- Power supply: lithium battery 3 V, service life 12 years
- Protection rating: IP68

Code	Type	Price €	Unit/Box
651 0532	for 6561D - 6562D - 6563CF		1/60



6561E
Pulse emitter cable. 1/10 pulse/
liter.



TECHNICAL SPECIFICATIONS

- Cable length: 1 m

Code	Type	Price €	Unit/Box
651 0085	For 6561C		1/10



6561MM
Compact M-BUS module



TECHNICAL SPECIFICATIONS

- Power supply: lithium battery, service life up to 12 years (with power supply M-Bus)
- Protection rating: IP68

Directly connectible to the M-Bus network

Code	Type	Price €	Unit/Box
651 0934	For 6561CR - 6561HR		1/50



6561MR
Compact radio module with
integrated 868 MHz WIRELESS
M-Bus inductive wireless sensor.



TECHNICAL SPECIFICATIONS

- Power supply: lithium battery, service life 11+1 years
- Protection rating: IP67

Code	Type	Price €	Unit/Box
651 0486	For 6561CR - 6561HR		1/40



6561RS
Pulse emitter REED SWITCH
type.
1/10 pulse/liter.



Code	Type	Price €	Unit/Box
651 0531	For 6561D		1/10



6583S
Reed sensor for Woltmann
meters.
1/100 pulse/liter.



TECHNICAL SPECIFICATIONS

- Contact type: reed switch (normally closed)
- Maximum permissible load 24 VAC - 0.1 A
- Protection rating: IP68
- Cable type: 2 x 0.25 mm²
- Cable length: 2 m
- Operating temperature: -25 °C ÷ +90 °C
- Storage temperature: -40 °C ÷ +90 °C

Code	Type	Price €	Unit/Box
651 0533	For 6563CF		1/40



6583MR
Wireless M-bus module.



TECHNICAL SPECIFICATIONS

- Frequency: 868/915 MHz
- Mode of data transmission: T1 (EN 13757)
- Management: inlet pulses, direction signals and alarms (handling, removal or presumed leaking)
- Configuration: via radio
- Power supply: lithium battery 3 V, service life 12 years
- Protection rating: IP68

Code	Type	Price €	Unit/Box
651 0532	for 6561D - 6562D - 6563CF		1/60



11c DOMESTIC WATER METERS

ACCESSORIES



6575C

Pulse adapter on M-Bus for meter pairs.

Code	Type	Price €	Unit/Box
651 0074	-		1/10



6570C

Electrical connections housing (only box to facilitate connections).

Code	Type	Price €	Unit/Box
651 0064	SHORTY/VARIO/FLOOR		1/10
651 0065	HEAT		1/10



1522

Union kit

 The kit includes: 2 tails, 2 nuts and 2 gaskets

Code	Ø Meter	Ø Fitting	Price €	Unit/Box
150 0035	3/4" F	1/2" M		1/80
150 0042	1" F	3/4" M		1/40
150 0062	1"1/4 F	1" M		1/20
150 0094	1"1/2 F	1"1/4 M		1/15
150 0072	2" F	1"1/2 M		1/10
150 0914	2"3/8 F	2" M		1/5
150 0101	2"1/2 F	2" M		1/5

12 INDIRECT METERING HEAT COST ALLOCATORS

12A Hydrothermal consumption metering

Indirect metering - introduction 244

The Tiemme indirect metering system 245

12B Heat cost allocators



246

12C Thermostatically-controlled valve kit with pre-setting



247

12D Thermostatically-controlled valve kit



249

12E Thermostat controls



251

In recent years, the ever greater focus on energy saving and the reduction of polluting emissions has steered the building industry toward the installation of centralized systems and heat metering systems able to determine the calories/frigorios used for ambient climate control in each unit of housing. The aim is to make each individual user completely autonomous in managing their own energy consumption. Therefore, each dwelling may manage its own system and accordingly its own energy consumption, which could not be done in the past since the expenditure was simply divided according to the property's thousandths shares.

The adoption of centralized systems with metering:

- Guarantees the ability to manage the heating requirements of each individual unit independently and then decide independently according to one's own hourly requirements;
- Saves on individual boiler maintenance costs (rather than one boiler for every apartment, only one boiler for all dwelling units);
- Frees up space within the home as accommodating boiler housing is not required;
- Guarantees greater safety to each individual dwelling unit by removing the presence of the boiler (additionally the presence of a centralized boiler ensures that periodic maintenance checks are carried out);
- Guarantees a general reduction in consumption and an accompanying reduction in harmful emissions, safeguarding the environment. Autonomous energy consumption management in a centralized system has been shown to lead to an overall energy saving for the building of up to 25%.

In order to benefit from the advantages linked to centralized management systems, along with those stemming from the autonomous management of each individual property unit's heating requirements, it is necessary to introduce systems for the individual metering of consumption.

In vertical riser distribution systems, if it is not possible to intercept the dwelling unit's single service circuit, the easily adoptable solution is indirect metering.

Indirect metering of heat is based on the value of energy drawn down by every single utility through the data collected on instruments installed on radiators (HEAT COST ALLOCATORS).

The heat cost allocator, therefore, becomes the obligatory instrument for the correct determination of usage in the majority of existing buildings with a centralized system, conforming to the provisions of the regulation in force (UNI 10200).

The regulation imposes contemporaneous installation of thermostatic valves and lockshield valves for regulation, to allow correct regulation of the thermal energy supplied to environments.

Through the installation of heat cost allocators, the user is equipped to responsibly manage the energy consumed, ensuring system-wide energy savings and an effective economic saving, in addition to the fairer division of expenditure compared to the previous system of division according to the property's thousandths shares.

MANAGEMENT WITH ENERGY WASTAGE

Without individual usage metering .

MANAGEMENT WITHOUT ENERGY WASTAGE

With usage metering and individual room thermoregulation.



A centralized heating system, on vertical risers, allows every individual dwelling to regulate their temperature autonomously. To quantify usage and divide the expenditure in proportion to how much each actually uses (voluntary consumption), TIEMME proposes the installation of a specific instrument, the HEAT COST ALLOCATOR.

WHAT IS A HEAT COST ALLOCATOR?

A heat cost allocator is an electronic heat meter that, installed on every single radiator body, allows it to monitor usage and share the data via radio. Installation is very simple and with aid of specialized equipment, the process is quick and does not require plastering or wiring.

WHAT DOES IT REQUIRE?

All the radiant bodies must be equipped with a Tiemme thermostatic kit which is made up of a valve, lockshield valve and thermostatic head (for regulating ambient temperature). The valve stops the flow of hot water from reaching the required temperature and reopens whenever necessary, reducing the operation of the generator with consequent energy saving. With the goal of better managing variations in flow rate, preventing the associated hisses and noises that can manifest, the installation within the central heating system of suitable balancing/bypass valves and a circulation pump is advisable.



HOW IS CONSUMPTION DIVIDED?

The legislation UNI 10200 "Heating systems - allocation of heating costs" supplies the chief instructions for the allocation of costs on the basis of the heat consumption of each utility on centralized heating and water production systems. The heat voluntarily drawn down by apartment buildings should be billed by consumption. The heat drawn down involuntarily (eg for communal areas, or dispersed along the distribution network) should be divided on the basis of heating thousandths.

HOW DOES THE READING WORK?

The usage data reading is carried out without accessing the individual dwelling units and therefore without causing disruption to apartment buildings. Data draws a summary picture of usage metering thanks to which you get to the right allocation of heating costs.

Data acquisition may occur via different methods:

- **Walk-by:** via a device carried by personnel responsible for carrying out readings;
- **Centralized:** via installation within the apartment building of a specific device for receipt and archiving of usage data.

For further details refer to the section "DATA COLLECTION AND READING SYSTEMS" within this catalog.

BENEFITS OF HEAT COST ALLOCATION:

- Money saving;
- Comfort: adjust according to your needs
- Fairness: only pay for what you use;
- Protect the environment: reduced consumption of fossil fuels and reduced CO₂ emissions
- Investment: an economically autonomous heating system = added value to your home
- Tax credit for the expense incurred;
- VAT subsidy in the case of building renovation;
- Safety: use of a single generator means set periodic checks
- Energy efficiency: for the same amount of fuel, a centralized boiler supplies more heat than all the individual autonomous boilers put together;
- Switch-on schedule: each user can freely manage their own system.

Heat cost allocators indirectly measure the usage of every heating body (radiators), via temperature tracking of heating body on which they are installed and the ambient temperature.

Through the proportionality parameters with thermal emission in the room, once the power of the installed radiator is noted, consumption can be determined.

A single dwelling unit's consumption can be derived in proportion to the values measured by the heat cost allocators present in all the other dwelling units that make up the apartment building.

Heat cost allocators are equipped with a display for local reading and provided with a 868 MHz radio in line with WIRELESS M-Bus (EN 13757) standards for remote communication with a suitable device for gathering data (either walk-by or centralized).

STRENGTHS

- Equipped with two sensors for the tracking of heating body and room temperature
- Battery life 11+ 1 years
- Equipped with tamper-proof seal
- Complete with a radio sensor for wireless communication.
- In line with regulation EN 834

PRODUCT RANGE



6580C

Heat cost allocator for centralized systems with riser distribution.



Code	Type	Price €	Unit/Box
651 0286	Standard		1/40



6580CS

Heat cost allocator for centralized systems with riser distribution With distance probe.



Code	Type	Price	Unit/Box
651 0287	With remote sensor.		1/40

ACCESSORIES AND SPARE PARTS



6561TUSB

USB optical head for programming or parameter modification on heat cost allocators and meters

i It also includes pairing to programming software for installation on PC. For more information contact the Tiemme Systems Department.

Code	Type	Price	Unit/Box
651 0051	For 6580C - 6580CS		1/10



12_C THERMOSTATICALLY-CONTROLLED VALVE WITH PRE-SETTING KIT



ADVANTAGES / STRENGTHS



Adjustable flow rate
The thermostatic valves series 331 and 332 are equipped with a fixed orifice water flow rate adjustment element which, via a six-position selector, allows choosing the correct flow rate to get all the system elements working correctly.



Simplified calibration
The screw adjustment method has been designed to make the installer's job easy. By working on the adjustment ring, without the aid of tools, it is possible to vary the valve flow rate by enlisting the help of the easily readable indicator located on the top of the valve.



Energy saving
The ability to accurately adjust every single utility and mount a thermostatic control means not only having the right ambient comfort level but also the right energy consumption level to get the fluid circulating, resulting in reducing energy usage.



Full range
Tiemme presents a new series of thermostatically-controlled valves with pre-setting included in the models and sizes. In fact, the range includes straight and angled valves with iron pipe fitting and male fitting for copper/PEX/multi-layer pipe adapters.

INSTRUCTIONS FOR CORRECT CALIBRATION

1



Unscrew hood from valve body.

2

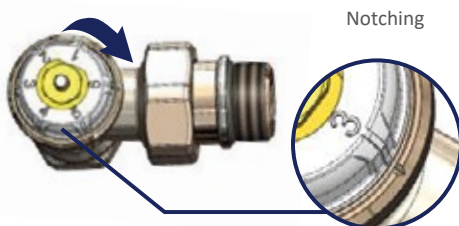

Turn the numbered handle until the number corresponding with the desired Kv (see table) is aligned with the reference notch on the valve body.

KV TABLE

Position		Kv (m ³ /h)
1		0.09
2		0.14
3		0.20
4		0.30
5		0.55
6		0.80

12c THERMOSTATICALLY-CONTROLLED VALVE KIT WITH PRE-SETTING

Thermostatically-controlled valve with pre-setting, thermostatic head and "EXCEL" lockshield valve (version with o-ring)



331HKIT

Three-piece kit comprising: angled valve **THERMOSTATICALLY-CONTROLLED WITH PRE-SETTING**, thermostatic head, **EXCEL angled lockshield valve** with fitting for iron pipe

+ PRE-SETTING

Code	Type	Price €	Unit/Box
331 0036	G 3/8"		1/10
331 0037	G 1/2"		1/10
331 0045	G 3/4"		1/10



331GKIT

Three-piece kit comprising: straight valve **THERMOSTATICALLY-CONTROLLED WITH PRE-SETTING**, thermostatic head, **EXCEL straight lockshield valve** with fitting for iron pipe

+ PRE-SETTING

Code	Type	Price €	Unit/Box
331 0038	G 3/8"		1/10
331 0039	G 1/2"		1/10
331 0044	G 3/4"		1/10



332HKIT

Three-piece kit comprising: angled valve **THERMOSTATICALLY-CONTROLLED WITH PRE-SETTING**, thermostatic head, **EXCEL angled lockshield valve** with fitting for copper, PEX and multilayer pipe

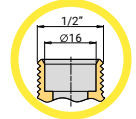

+ PRE-SETTING

Code	Type	Fittings	Price €	Unit/Box
331 0040	G 3/8"	1/2" (ø16)		1/10
331 0041	G 1/2"	1/2" (ø16)		1/10



332GKIT

Three-piece kit comprising: straight valve **THERMOSTATICALLY-CONTROLLED WITH PRE-SETTING**, thermostatic head, **EXCEL straight lockshield valve** with fitting for copper, PEX and multilayer pipe

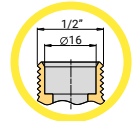

+ PRE-SETTING

Code	Type	Fittings	Price €	Unit/Box
331 0042	G 3/8"	1/2" (ø16)		1/10
331 0043	G 1/2"	1/2" (ø16)		1/10



12_D THERMOSTATICALLY-CONTROLLED VALVE KIT

Thermostatically-controlled valve, thermostatic head and "EXCEL" lockshield valve (version with o-ring)



3308KIT04R

Three-piece kit comprising: **THERMOSTATICALLY-CONTROLLED** angled valve, thermostatic head, **EXCEL** angled lockshield valve with fitting for iron pipe

Code	Type	Price €	Unit/Box
330 0141	G 3/8"		1/10
330 0142	G 1/2"		1/10
330 0150	G 3/4"		1/10



3307KIT04R

Three-piece kit comprising: **THERMOSTATICALLY-CONTROLLED** straight valve, thermostatic head, **EXCEL** straight lockshield valve with fitting for iron pipe

Code	Type	Price €	Unit/Box
330 0143	G 3/8"		1/10
330 0144	G 1/2"		1/10
330 0151	G 3/4"		1/10



3303KIT04R

Three-piece kit comprising: **THERMOSTATICALLY-CONTROLLED** angled valve, thermostatic head, **EXCEL** angled lockshield valve with fitting for copper, PEX and multilayer pipe

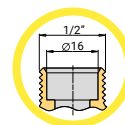

Code	Type	Fittings	Price €	Unit/Box
330 0145	G 3/8"	1/2" (ø16)		1/10
330 0146	G 1/2"	1/2" (ø16)		1/10



3302KIT04R

Three-piece kit comprising: **THERMOSTATICALLY-CONTROLLED** straight valve, thermostatic head, **EXCEL** straight lockshield valve with fitting for copper, PEX and multilayer pipe

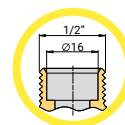

Code	Type	Fittings	Price €	Unit/Box
330 0147	G 3/8"	1/2" (ø16)		1/10
330 0148	G 1/2"	1/2" (ø16)		1/10

12_D THERMOSTATICALLY-CONTROLLED VALVE KIT

Thermostatically-controlled valve, thermostatic head and lockshield valve



3308KIT03

Three-piece kit comprising: **THERMOSTATICALLY-CONTROLLED** angled valve, thermostatic head, angled lockshield valve with fitting for iron pipe

Code	Type	Price €	Unit/Box
330 0133	G 3/8"		1/10
330 0134	G 1/2"		1/10
330 0166	G 3/4"		1/10



3307KIT03

Three-piece kit comprising: **THERMOSTATICALLY-CONTROLLED** straight valve, thermostatic head, straight lockshield valve with fitting for iron pipe

Code	Type	Price €	Unit/Box
330 0135	G 3/8"		1/10
330 0136	G 1/2"		1/10
330 0167	G 3/4"		1/10



3303KIT03

Three-piece kit comprising: **THERMOSTATICALLY-CONTROLLED** angled valve, thermostatic head, angled lockshield valve with fitting for copper, PEX and multilayer pipe

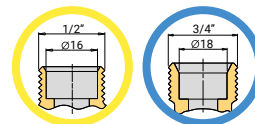

Code	Type	Fittings	Price €	Unit/Box
330 0137	G 3/8"	1/2" (ø16)		1/10
330 0138	G 1/2"	1/2" (ø16)		1/10
330 0206	G 1/2"	3/4" (ø18)		1/10



3302KIT03

Three-piece kit comprising: **THERMOSTATICALLY-CONTROLLED** straight valve, thermostatic head, straight lockshield valve with fitting for copper, PEX and multilayer pipe

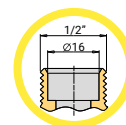

Code	Type	Fittings	Price €	Unit/Box
330 0139	G 3/8"	1/2" (ø16)		1/10
330 0140	G 1/2"	1/2" (ø16)		1/10





Thermostatic controls art. 9553 - 9553C meet the requirements of the Italian Ministry of Economy and Finance Decree dated 19 February 2007 and decree law 6 Dicembre 2011 and subsequent.

ADVANTAGES / STRENGTHS



Quality materials

The Tiemme thermostatic control is produced with high-grade materials and with superior quality mechanics and TECHNICAL SPECIFICATIONS.

Pleasant feel and durability are only two of the elements that characterize the product.



Ergonomic, functional design

Whether in public or private spaces, the clean lines guarantee perfect compatibility between product and placement. The minimal design has been optimized to offer the best in terms of speed of installation and ease of use. Customization and indication of use values are minimal and brought about in such a way as to help, not confuse.



Italian product with a German core

The production process takes place entirely within Tiemme's Italian plants, where the perfect operation of every product is checked and guaranteed before dispatch. Only as far as regards the choice of sensor element we have looked to German technology, perennially at the cutting edge for this type of component.



Intelligent temperature limiting

The control 9553 offers the option of limiting the usage temperature to predefined values.

By inserting the special clips (available on request) it is possible to define a limited range of values or to limit the temperature to a precise value.



9553
Thermostatic head with built-in liquid sensor temperature range 6-28°C

Code	Type	Price €	Unit/Box
955 0025	M30 x 1.5		1/30



9553C
Chrome-plated thermostatic head with built-in liquid sensor. Temperature range 6-28°C

Code	Type	Price €	Unit/Box
955 0026	M30 x 1.5		1/30



9558
Thermostatic head with remote liquid sensor. Capillary length 2 m

Code	Type	Price €	Unit/Box
955 0003	M30 x 1.5		1/15



9551
Thermostatic head with remote control. Capillary length 2 m

Code	Type	Price €	Unit/Box
955 0029	M30 x 1.5		1/5



9553INS
Pair of inserts for temperature limitation for thermostatic head 9553/9553C

Code	Type	Price €	Unit/Box
955 0037	-		5/50



9553AM2
Vandal proof and anti-tampering kit for thermostatic head 9553/9553C

Code	Type	Price €	Unit/Box
955 0033	-		20/80



9553CHT
Key for vandal proof and anti-tampering thermostatic head kit 9553/9553C

Code	Type	Price €	Unit/Box
955 0038	-		1/1



9553AM1
Six anti-vandal and anti-tampering knobs for thermostatic head 9553/9553C including tool

Code	Type	Price €	Unit/Box
955 0036	-		1/4



9556
Programmable electronic thermostatic head. Temperature range 8-28°C

Code	Type	Price €	Unit/Box
955 0015	M30 x 1.5		1/5



9556USB
USB programming key for electronic thermostatic head

Code	Type	Price €	Unit/Box
955 0017	-		10/40



13 TEMPERATURE CONTROLS

13A Thermostats and chronothermostats



254

13B Wireless temperature controls



257

13C Wi-Fi temperature controls



260



9575
Electro-mechanical room thermostat

TECHNICAL CHARACTERISTICS

- Output: normally open contact 16(2,5) A/250 Vac
- Temperature range: 5-30°C
- Differential: ± 0,5°C

Code	Type	Price €	Unit/Box
957 0002	electro-mechanical		1/40



9573
Built-in electronic room thermostat

TECHNICAL SPECIFICATIONS

- Power supply: Two AAA 1.5 V batteries
- Outlet: 8(5) A/250 Vac no voltage input exchange relay
- Function SUMMER-WINTER-OFF
- Adjusting range: 2-50°C
- Min. switching time: 1 minute
- Differential: adjustable from 0.1 to 1°C

 Thanks to different assembly frames provided, the thermostat can be adjusted to widespread plaques and integrated with the civil series employed.

Code	Type	Price €	Unit/Box
957 0008	electronic		1/5



9574
Built-in digital weekly chronothermostat

TECHNICAL SPECIFICATIONS

- Power supply: Two AAA 1.5 V batteries
- Outlet: 8(5) A/250 Vac no voltage input exchange relay
- Function SUMMER-WINTER
- Adjusting range: 2-50°C
- Daily resolution: 1 hour
- Differential: adjustable from 0.1 to 1°C

 Thanks to different assembly frames provided, the thermostat can be adjusted to widespread plaques and integrated with the civil series employed.

Code	Type	Price €	Unit/Box
957 0015	weekly electronic		1/5



9581
Touchscreen electronic room thermostat

TECHNICAL CHARACTERISTICS

- Display touchscreen
- Power supply: 2 x 1,5V miny stylus batteries (AAA)
- Battery life: 1 year
- Output: relay with exchange contact 5 A (230 Vac) free of voltage
- SUMMER-WINTER-OFF functions
- Digital input for 3°C reduction setpoint
- Regulation range: 2-50°C
- Differential: adjustable from 0,1 to 1°C

Code	Type	Price €	Unit/Box
957 0155	electronic		1/10



9580
Touchscreen electronic room cronothermostat

TECHNICAL CHARACTERISTICS

- Display touchscreen
- Power supply: 2 x 1,5V miny stylus batteries (AAA)
- Battery life: 1 year
- Output: relay with exchange contact 5 A (230 Vac) free of voltage
- SUMMER-WINTER-OFF functions
- Programming weekly with 3 temperature levels
- Regulation range: 2-50°C
- Differential: adjustable from 0,1 to 1°C

Code	Type	Price €	Unit/Box
957 0154	electronic-weekly		1/10





9567
Electrothermal actuator

Code	Type	Price €	Unit/Box
450 0026	24V		1/20
450 0012	230V		1/20
450 0045	24V		1/20
450 0006	230V		1/20

Auxiliary microswitch version



9568
Electrothermal actuator
(for thermostatic valves and polyamid manifold art. 3872POL - 3871PMON)

Code	Type	Price €	Unit/Box
450 0543	24V		1/20
450 0539	230V		1/20
450 0545	24V		1/20
450 0541	230V		1/20

Auxiliary microswitch version

9568

INSTALLATION EXAMPLE

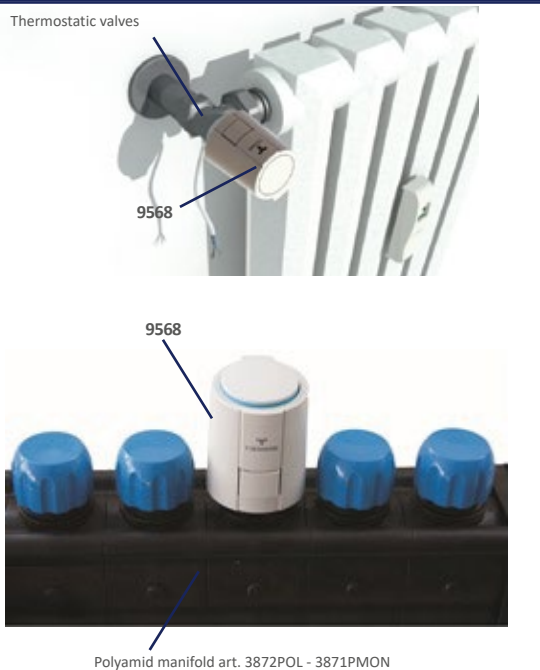

13A THERMOSTATS AND CHRONOTHERMOSTATS



4625D

10 channel control unit to connect the room thermostat (wire connection) and the relevant electrothermal actuators, output relay for pump 230Vac 5(2)A

Code	Type	Price €	Unit/Box
957 0005	230V		1/6

With output relay for pump

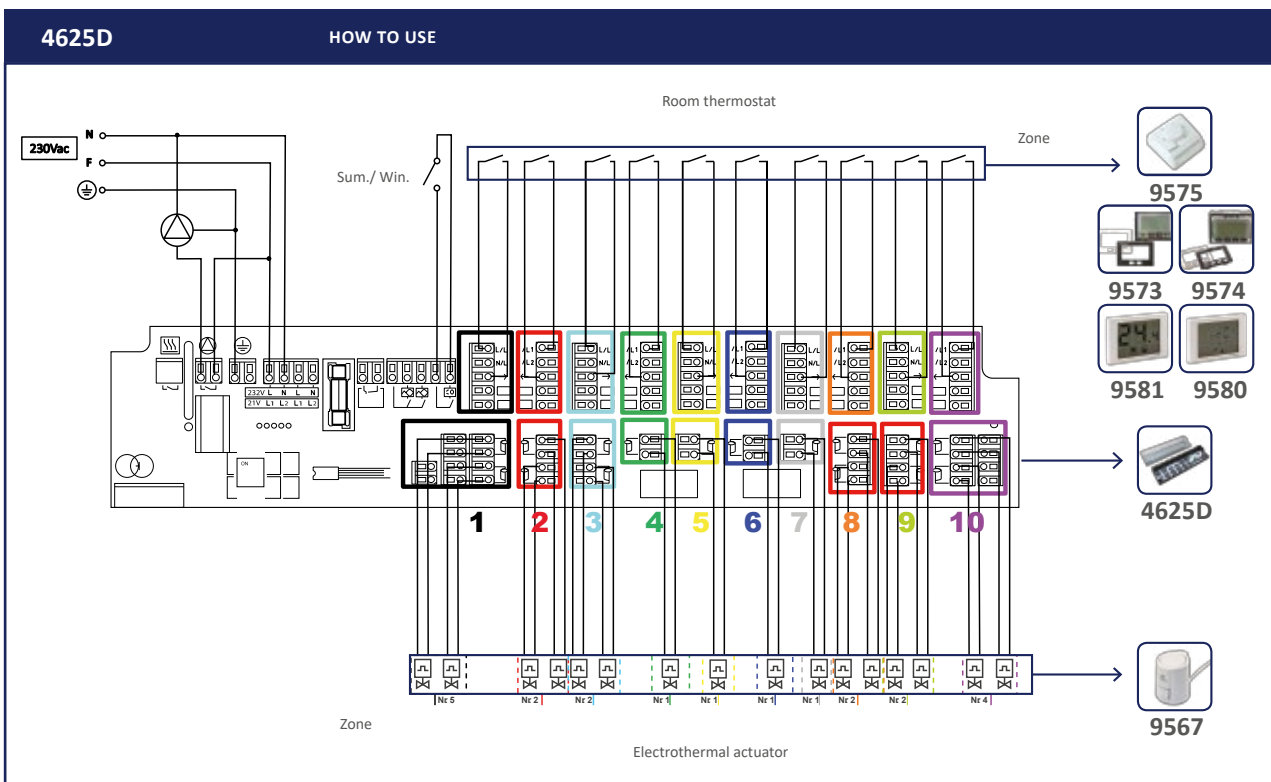

Wireless temperature controls allow ambient climate adjustment without investing in masonry work. Thanks to wireless technology the various elements communicate and control the opening or closing of devices (boiler/heat pump/radiator valves) according to the user's specified profile comfort profile, the whole thing running on battery power.



4601
Electronic touchscreen wireless room thermostat

TECHNICAL SPECIFICATIONS

- Touchscreen display
- Power supply: 2 batteries 1.5V (type AAA)
- Battery life: 1 year
- Transmission frequency: 433.92 MHz
- SUMMER-WINTER-OFF switch
- Adjustment range: 2-50°C
- Differential: adjustable from 0.1 to 1°C

Code	Type	Price €	Unit/Box
957 0156	electronic		1/10



9580W
Electronic touchscreen wireless room chronothermostat

TECHNICAL SPECIFICATIONS

- Touchscreen display
- Power supply: 2 batteries 1.5V (type AAA)
- Battery life: 1 year
- Transmission frequency: 433.92 MHz
- SUMMER-WINTER-OFF switch
- 7-Day programming with three temperature levels
- Adjustment range: 2-50°C
- Differential: adjustable from 0.1 to 1°C

Code	Type	Price €	Unit/Box
957 0172	7-day electronic		1/10

OPERATION ART. 4606

Load activation (air-conditioning, boiler etc) occurs via the remote receiver which is remote controlled by the thermostat (included in kit) across a radio frequency signal. This makes it possible to situate the thermostat anywhere within your home without having to run cabling.



4606
Wireless temperature adjustment system with touchscreen thermostat and single-channel receiver

TECHNICAL SPECIFICATIONS

- THERMOSTAT**
- see TECHNICAL SPECIFICATIONS art. 4601
- RECEIVER**
- see TECHNICAL SPECIFICATIONS art. 4607

Code	Type	Price €	Unit/Box
957 0157	electronic		1/4

OPERATION ART. 4607

Load activation (air-conditioning, boiler etc) occurs via the remote receiver which is remote controlled by the thermostat/chronothermostat (ordered separately) across a radio frequency signal. This makes it possible to situate the the thermostat anywhere within your home without having to run cabling.



4607

Single-channel radio receiver with control for boiler/heat pump/circulating pump

TECHNICAL SPECIFICATIONS

- Power supply: 230 VAC 50 Hz
- 2 DIN module version
- Outlet: free changeover relay rated 8 A (230VAC)

Code	Type	Price €	Unit/Box
957 0183	electronic		1/25

OPERATION ART. 4612

It has been designed to control climate control (hot/cold) equipment by receiving control signals originating from wireless thermostats/chronothermostats (ordered separately) across a radio frequency signal. Features six relays to control up to six zone valves plus a further relay for connecting the circulation pump. Activation of this latter control can be delayed (from 3 seconds to f5 minutes) using the trimmer on the front.



4612

Six-channel wireless receiver electrothermal actuators 9567

TECHNICAL SPECIFICATIONS

- Power supply: 230 VAC 50 Hz
- No. channels: 6
- Actuator control: 5 A (230VAC) relay contact
- Pump control: 5 A (230VAC) relay contact
- Pump control delay settable from 3 seconds to 5 minutes
- External antenna included in the packaging
- 4 DIN module version

Code	Type	Price €	Unit/Box
957 0158	electronic		1/4



9556W

Wireless programmable electronic thermostatic head. Temperature range 8-28°C

TECHNICAL SPECIFICATIONS

- Power supply: 2 batteries 1.5V type AA
- Battery life: 5 years (low battery indicator)
- Adjustment type:
 - for radio frequency function: ON/OFF according to the parameters received from the thermostat/chronothermostat RF
 - for automatic/manual function: modulation of valve opening according to set-point, measured temperature and environment features
- OPERATION:
 - Radio frequency controlled by the associated RF thermostat/chronothermostat
 - automatic with two temperature levels (comfort and economy)
 - manual with temperature set via the selection wheel
- Maximum daily switching number for automatic function 4 in comfort and 4 in economy
- Operating temperature: 0 ÷ 50°C
- Storage temperature: -20 ÷ +70°C
- Temperature adjustment: 8÷ 28°C
- Piston force: >100 N
- Protection rating: IP30
- Dimensions (WxHxD): 52 x 83 x 65 mm

Code	Type	Price €	Unit/Box
955 0027	M30 x 1.5		1/5



13_B WIRELESS TEMPERATURE CONTROLS

9556W-4601-9580W

INSTALLATION EXAMPLE



4601-4612-9567

INSTALLATION EXAMPLE

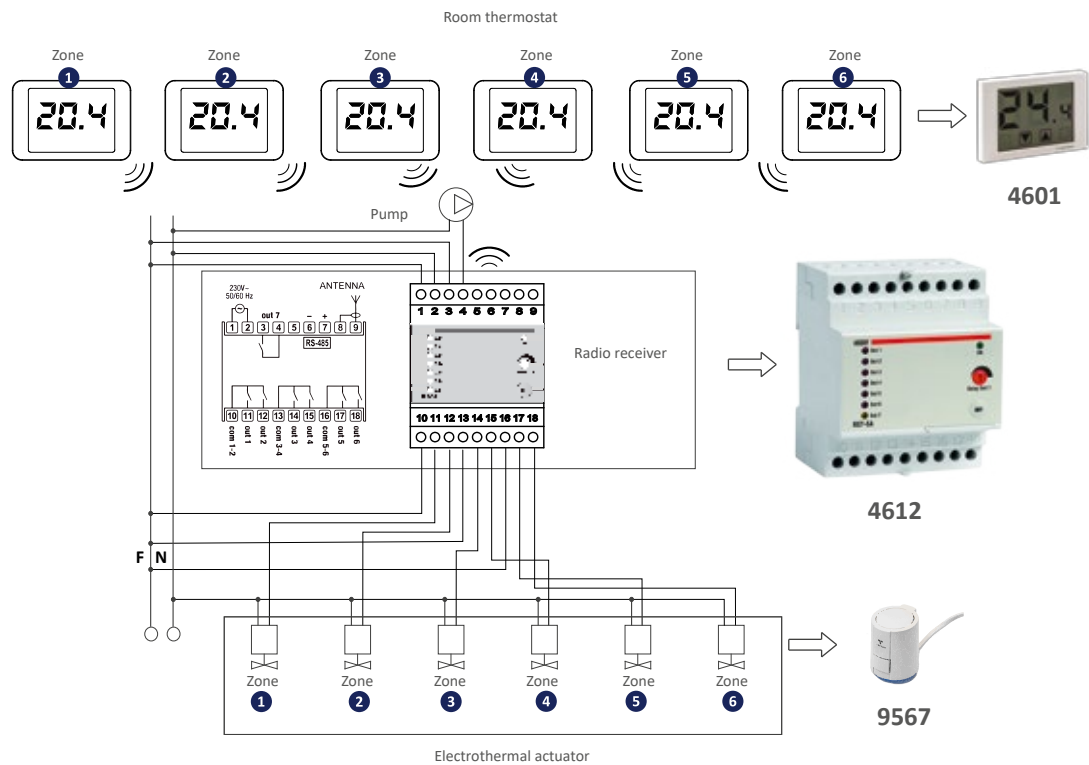

13c WI-FI TEMPERATURE CONTROLS

TIEMME NEXT

Digital electronic chronothermostats with Wi-Fi communication can remotely manage climate control with an App.

Integrated Wi-Fi module allows to remotely control the chronothermostat with your smartphone. You only need to connect the device to your router and install the TIEMME NEXT App on your smartphone, freely available for iOS and Android devices.

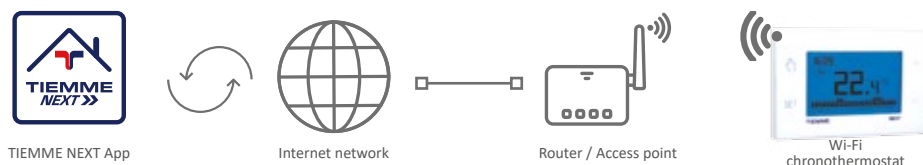

Available for



9589
TIEMME NEXT wall weekly chronothermostat in white Wi-Fi communication.

TECHNICAL SPECIFICATIONS

- Power supply: 230Vac \pm 10% 50/60 Hz/ 4 x 1,5V batteries (AA)
- Outlet: 5 A (250 Vac) no voltage input exchange relay
- Winter/Summer/Off mode
- Schedule: Weekly with 3 levels of temperature (T1 - T2 - T3)
- Adjusting range: 2.0 \div 50.0 °C
- Temperature control: ON/OFF with adjustable differential (0.1 \div 1.0 °C) or proportional with adjustable range
- Wi-Fi module to connect with TIEMME NEXT App
- Installation: On the wall, 130 x 85 th.28 mm

Code	Type	Price €	Unit/Box
957 0201	230 Vac		1/10
957 0211	4 x 1,5 V AA		1/10



9590
TIEMME NEXT RF wall weekly chronothermostat with humidity sensor in white. Wi-Fi communication and RF (radio frequency)

TECHNICAL SPECIFICATIONS

- Power supply: 230Vac \pm 10% 50/60 Hz
- Winter/Summer/Off mode
- Schedule: Weekly with 3 levels of temperature (T1 - T2 - T3)
- Adjusting range: 2.0 \div 50.0 °C
- Temperature control: ON/OFF with adjustable differential (0.1 \div 1.0 °C) or proportional with adjustable range
- Wi-Fi module to connect with TIEMME NEXT App
- Radio frequency module to manage 3 controls (Temperature/Humidity/CMV)
- Frequency range: 433.92 MHz
- Installation: On the wall, 130 x 85 th.28 mm

With humidity sensor

With integrated radio frequency module to communicate with radio receiver no. 4607 - 4612 or thermostatic head no. 9556W

Code	Type	Price €	Unit/Box
957 0203	230 Vac		1/10



9591
TIEMME NEXT IN built-in weekly chronothermostat (square box) . Wi-Fi communication

TECHNICAL SPECIFICATIONS

- Power supply: 230Vac \pm 10% 50/60 Hz
- Outlet: 5 A (250 Vac) no voltage input exchange relay
- Winter/Summer/Off mode
- Schedule: Weekly with 3 levels of temperature (T1 - T2 - T3)
- Adjusting range: 2.0 \div 50.0 °C
- Temperature control: ON/OFF with adjustable differential (0.1 \div 1.0 °C) or proportional with adjustable range
- Wi-Fi module to connect with TIEMME NEXT App
- Built-in (2 module) installation in the main residential series (Bticino, Vimar, Ave, Gewiss)

Code	Type	Price €	Unit/Box
957 0205	230 Vac		1/5



9592
TIEMME NEXT RD built-in weekly chronothermostat (round box). Wi-Fi communication

TECHNICAL SPECIFICATIONS

- Power supply: 230Vac \pm 10% 50/60 Hz
- Outlet: 5 A (250 Vac) no voltage input exchange relay
- Winter/Summer/Off mode
- Schedule: Weekly with 3 levels of temperature (T1 - T2 - T3)
- Adjusting range: 2.0 \div 50.0 °C
- Temperature control: ON/OFF with adjustable differential (0.1 \div 1.0 °C) or proportional with adjustable range
- Wi-Fi module to connect with TIEMME NEXT App
- Built-in installation (round box with 60 mm spacing)

Code	Type	Price €	Unit/Box
957 0207	230 Vac		1/5



14

DATA COLLECTION AND READING SYSTEMS

14A Data collection and reading systems 262

14B M-Bus dataloggers



263

14C Radio dataloggers







267

14_A DATA COLLECTION AND READING SYSTEMS - INTRODUCTION

The ultimate goal of DIRECT and INDIRECT metering is the determination of consumption data for each individual housing unit, so as to proceed with the correct invoicing of expenditure.

Tiemme proposes different devices and systems for collecting and reading data, according to the requirements of the single apartment block.

Nr.	Product description	Type of data transmission	Type of reading	Manageable metering tool
1	M-Bus datalogger		Centralized	M-Bus meters
2	USB transceiver		Walk-by	Wireless meters and heat allocators
3	Transceiver		Walk-by	Wireless meters and heat allocators
4	Datalogger		Centralized	Wireless meters and heat allocators



1



2



3



4



14_B M-BUS DATALOGGERS

INTRODUCTION

M-Bus dataloggers are electronic data collection devices;

They acquire data relating to thermal energy and domestic water consumption from all the devices that make up the system (thermal energy meters and volumetric meters) connected to the M-Bus network.

The consumption data can be read either locally via display or MMC memory card, or remotely by sending an e-mail via the GSM/GPRS network (the device must be equipped with a data SIM card); the latter solution allows to interact remotely with the logger, granting access to all settings.

The single possibilities are summarized on the following pages in order to properly choose the components of the system:

Two models of loggers are available depending on the maximum number of devices that can be managed (up to 32 and up to 250 units respectively).

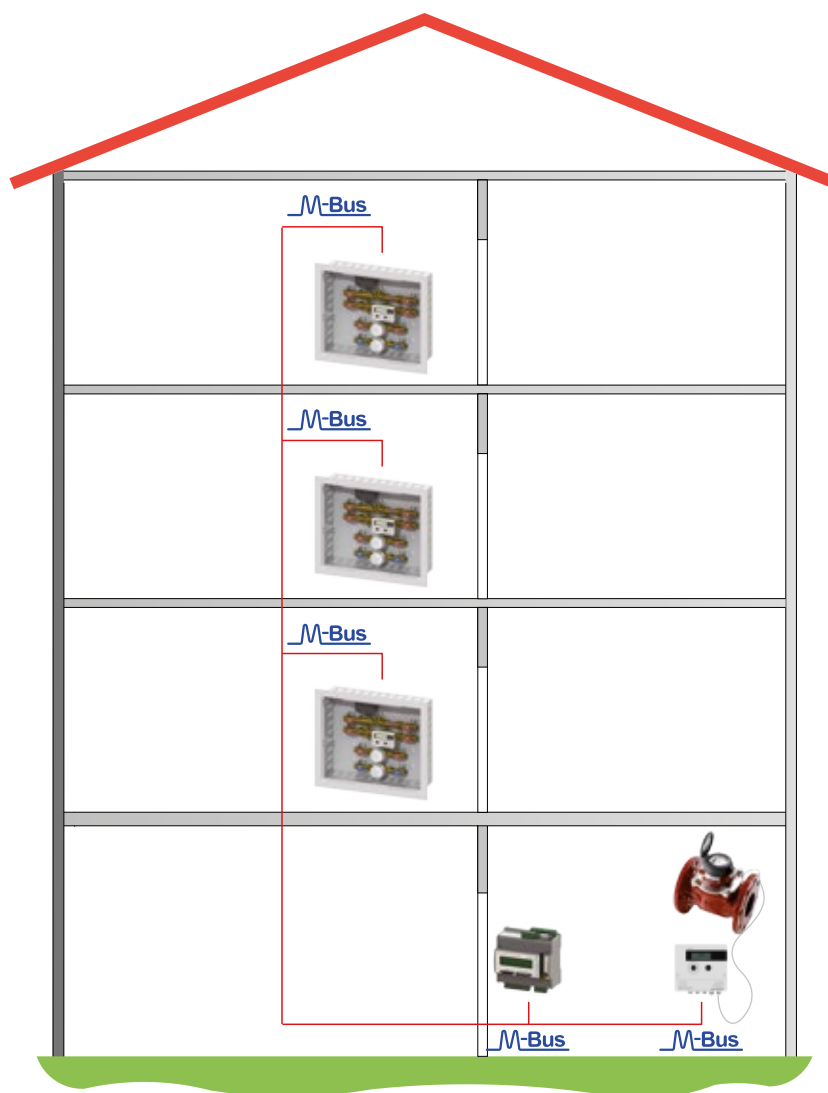

SOLUTION A: "LOCAL M-BUS" SYSTEM

Local reading system via memory card.

SOLUTION B: "REMOTE M-BUS" SYSTEM

Remote reading system via data SIM card.

14_B M-BUS DATALOGGERS

“LOCAL M-BUS” SYSTEM

In the “Local M-Bus” system, the receiver is permanently installed in the building where it logs consumption data. The system consists of a centralized datalogger and an M-Bus network to which all the accounting devices (thermal energy meters and domestic meters) and the datalogger itself are connected.

The consumption data is read locally via the display or MMC memory card.

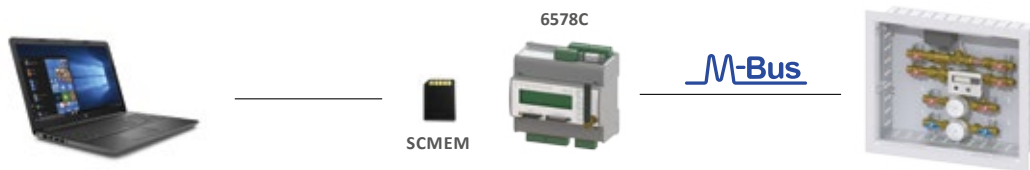

PRODUCT RANGE



6578C

M-Bus datalogger for DIN-rail installation with display and GSM/GPRS data transmission.

TECHNICAL SPECIFICATIONS

- Power supply 230 Vac - 50/60 Hz
- Colored LEDs for operation diagnostics and fault indication
- LCD display
- MMC reading reports extraction
- Datalogger settings and data reading of M-Bus network can be carried out by sending text messages from any mobile phone
- Export read reports in CSV format
- Sending reading reports to one or more e-mail addresses (up to 4)

Code	Type	Price €	Unit/Box
651 0423	max. 250 units		1/4

ACCESSORIES AND SPARE PARTS



SCMEM

MMC memory card for 128 MB data transfer

 Special accessory for local reading

Code	Type	Price €	Unit/Box
651 0651	128 MB		1/100



14_B M-BUS DATALOGGERS

“REMOTE M-BUS” SYSTEM

In the “remote M-Bus” system, the receiver is permanently installed in the building where it logs consumption data. The system consists of a centralized datalogger and an M-Bus network to which all the accounting devices (thermal energy meters and domestic meters) and the datalogger itself are connected.

The reading of the consumption data is performed remotely by sending an e-mail message through the GSM/GPRS network, the device must be equipped with data SIM card (not supplied by Tiemme).

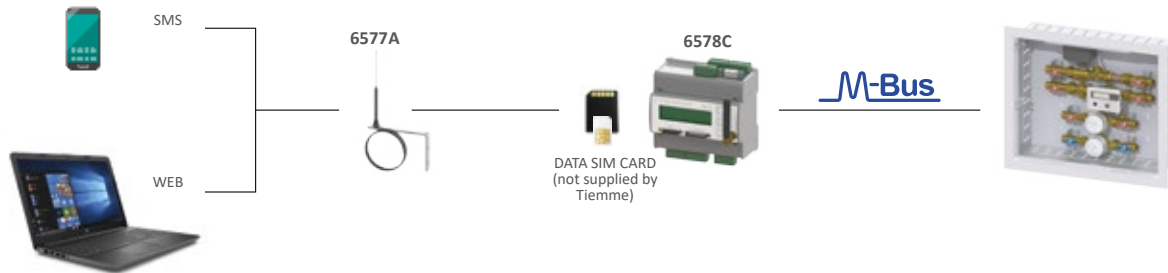

PRODUCT RANGE



6578C
M-Bus datalogger for DIN-rail installation with display and GSM/GPRS data transmission.

TECHNICAL SPECIFICATIONS

- Power supply 230 Vac - 50/60 Hz
- Colored LEDs for operation diagnostics and fault indication
- LCD display
- MMC reading reports extraction
- Datalogger settings and data reading of M-Bus network can be carried out by sending text messages from any mobile phone
- Export read reports in CSV format
- Sending reading reports to one or more e-mail addresses (up to 4)

Code	Type	Price €	Unit/Box
651 0423	max. 250 units		1/4

ACCESSORIES AND SPARE PARTS



6577A
Compact antenna for GSM applications. External wall mount, 3 m cable

i Specific remote reading accessory to match with SIM card (not supplied by Tiemme)

Code	Type	Price €	Unit/Box
651 0435	GSM		1/10

WHAT IS THE M-BUS NETWORK

The M-Bus is a communication interface according to European standards EN 1434 and EN 13757, conceived in Germany. It has quickly become a standard for thermal energy, water, gas and electricity meter reading systems .

The M-Bus network consists mainly in the laying of a double conductor cable with specific features (J-Y-ST-Y 2 x 0,8 mm - resistance 75 Ω/km - capacity 150 nF/km) along which the calorimeters are connected according to specific layouts.

It is mandatory to lay the cable inside dedicated pipes for communication cables and not inside sections with loaded power cables, in order not to affect the data transmission/correctness. One end of the cable is then connected to the pulse datalogger, which must be chosen appropriately because it has a maximum number of peripherals (meters) that can be connected according to the specific model.

No termination is required at the other end of the cable nor any grounding. The laying of an M-Bus network must be entrusted to qualified personnel who must respect some specific parameters such as the type of installation (see diagrams below), the type and length of the cable, so to ensure a correct functioning and therefore a correct reading of the measurements carried out by the meters/calorimeters.

M-Bus network

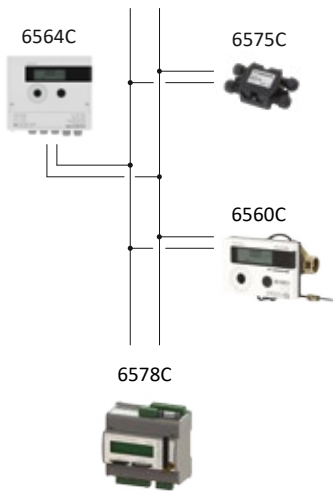

BACKBONE

M-Bus network

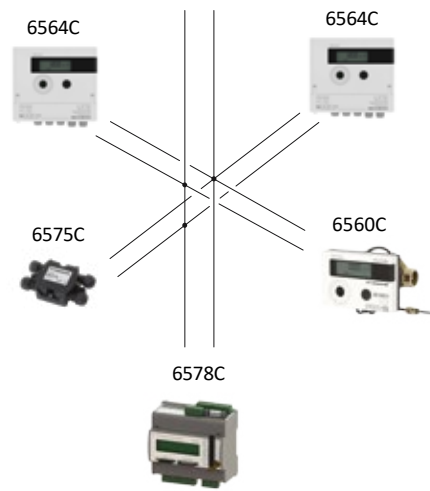

STAR

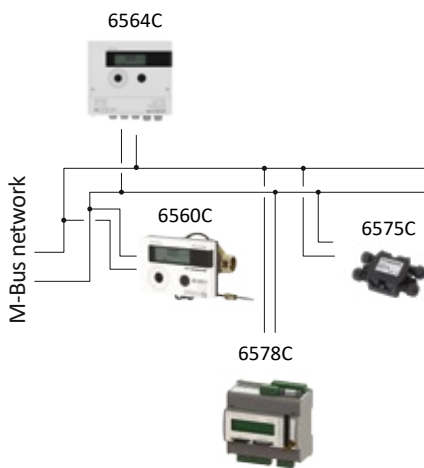

TREE

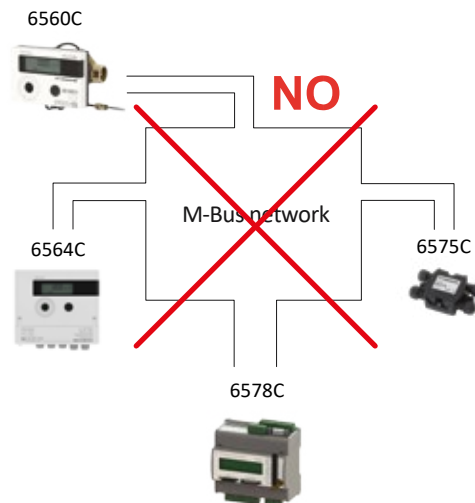

RING



14c RADIO DATALOGGERS

INTRODUCTION

Radio dataloggers are electronic data collection devices;

They acquire thermal energy and domestic water consumption data from all the devices that make up the system (heat dividers, heat energy meters and volumetric meters) equipped with a 868 MHz radio communication interface compliant with Wireless M-Bus (EN 13757).

The consumption data is read needing no access to the property units and therefore bothering no neighbor. The data acquisition can take place in different ways according to the requirements of the single building:

- **WALK-BY:** using a device provided by the staff responsible for taking readings.
- **CENTRALIZED:** by installation inside the building of a suitable device for receiving and storing consumption data.

The single possibilities are summarized on the following pages in order to properly choose the components of the system:

WALK-BY DATA CAPTURE

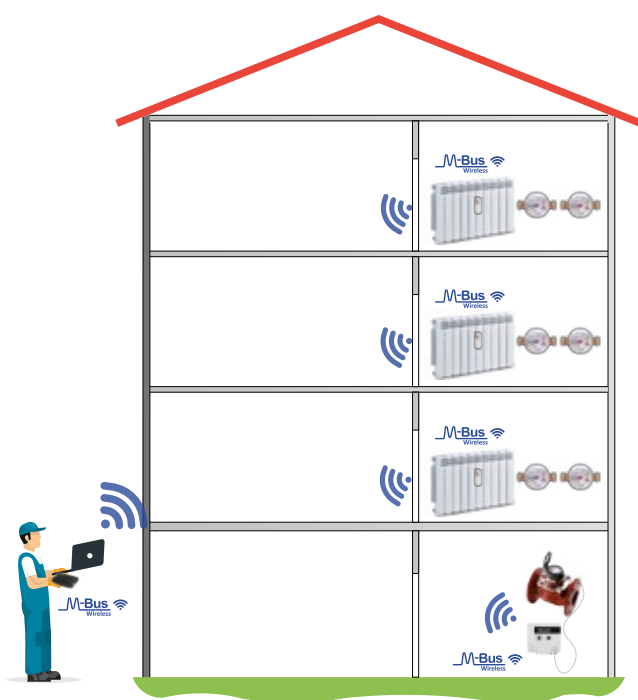

CENTRALIZED DATA CAPTURE



SOLUTION A: "FIXED RADIO SMART KIT" SYSTEM
Connect the PC to the logger using an ethernet cable

SOLUTION B: "REMOTE RADIO SMART KIT" SYSTEM
Data transmission to PC via router

14c RADIO DATALOGGERS

“WALK-BY” SYSTEM

In the “walk-by” system the radio receiver is mobile, that is to say at the disposal of the reader who is to be near the meters requiring no access to the installation point of the latter.

The walk-by reading mode allows the choice between two different devices, radio transceiver for mobile reading of consumption data or USB radio transceiver to be inserted in the notebook used for reading and managing data.

Both devices provide for the matching with appropriate reading software to be installed on PC/tablet for the management of the collected data.

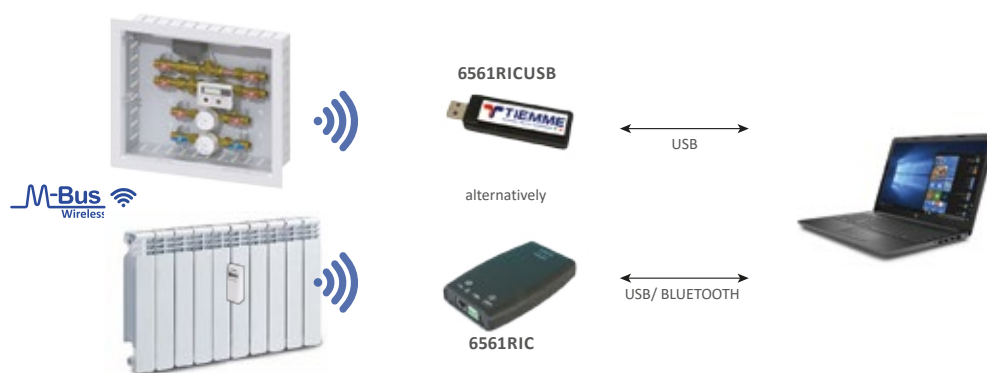

PRODUCT RANGE



6561RICUSB

USB transceiver for receiving and storing consumption data of 868 MHz WIRELESS M-Bus radio meters.



6561RIC

Transceiver for receiving and storing consumption data of 868 MHz WIRELESS M-Bus radio meters.

Code	Type	Price €	Unit/Box
651 0559	USB 868 MHz radio transceiver		1/1
651 0475	License + PC/tablet mobile reading software		1/1

Code	Type	Price €	Unit/Box
651 0474	Mobile transceiver		1/1
651 0475	License + PC/tablet mobile reading software		1/1



14c RADIO DATALOGGERS

“FIXED RADIO SMART KIT” SYSTEM

In the “fixed Radio Smart Kit” system, the radio receiver is permanently installed in the building whose consumption data it collects. The system consists of a centralized logger and a self-setting network of allocators for collecting the information of the devices present.

By connecting the Datalogger directly to the PC via Ethernet connection, the consumption data can be read out. Datalogger can read up to 500 devices.



PRODUCT RANGE



6582RIC

Datalogger for receiving and storing consumption data of 868 MHz WIRELESS M-Bus radio meters.

Repeater included.

i Maximum connected devices: 500 (+ 20 wired M-Bus devices)

Code	Price €	Unit/Box
651 0528		1/1



6582

Radio repeater/receiver for receiving consumption data of 868 MHz WIRELESS M-Bus radio meters.

i “Multi-hop open” feature allows you to extend coverage network when used with other repeaters

Code	Price €	Unit/Box
651 0529		1/1

14c RADIO DATALOGGERS

“REMOTE RADIO SMART KIT” SYSTEM

In the “Remote Radio Smart Kit” system, the radio receiver is permanently installed in the building whose consumption data it collects.

The system consists of a centralized datalogger and a self-setting network of allocators for collecting the information of the devices present.

The data is sent to the PC via a wireless connection with a 3G router.

Datalogger can read up to 500 devices.

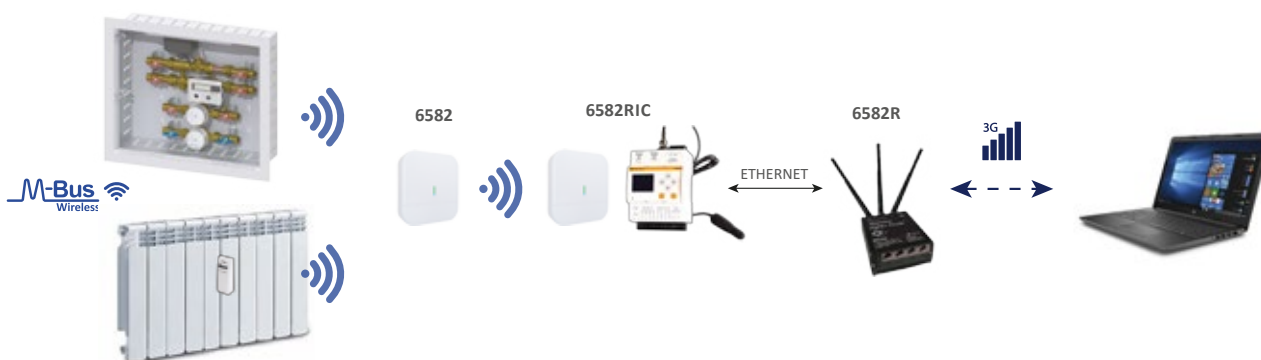

PRODUCT RANGE



6582RIC

Datalogger for receiving and storing consumption data of 868 MHz WIRELESS M-Bus radio meters.
Repeater included.

i Maximum connected devices: 500 (+ 20 wired M-Bus devices)

Code	Price €	Unit/Box
651 0528		1/1



6582

Radio repeater/receiver for receiving consumption data of 868 MHz WIRELESS M-Bus radio meters.

i “Multi-hop open” feature allows you to extend coverage network when used with other repeaters

Code	Price €	Unit/Box
651 0529		1/1



6582R

Compact 3G router with wireless and Ethernet connections.

i Possibility of remote transmission of metering data by means of combination with datalogger art. 6582RIC

i SIM card for data transmission not provided by Tiemme

Code	Price €	Unit/Box
651 0530		1/1





PRODUCTS QUALITY

TIEMME RACCORDERIE S.p.A.
manufacturer of complete heating, sanitary and gas systems
situated in Castegnato (Brescia) Via Cavallera, 6/A
as per Ministerial Decree 37/08 "Plants Installation"
and as per 10/91 law

DECLARES

that all the products distributed to the customers
are designed and manufactured in compliance with technical regulation
and quality criteria required by International Standards EN ISO 9000.

The quality of TIEMME products
has been awarded with ISO 9001 certification
acknowledging the Company's commitment
to the development, production and marketing
of its goods.

The Legal Representative

FACSIMILE COPY

The originals and the full text of the rules mentioned are available at the legal office of
TIEMME RACCORDERIE S.p.A. Via di San Giovanni - 25045 - Castegnato (Bs)

The products manufactured by Tiemme Raccorderie S.p.A. (hereinafter referred to as "Company") are guaranteed for 2 years from the date of shipment from its premises. This warranty is additional to and does not affect the buyer's rights under the European Directive 99/44/CE and its national implementing decree, except where otherwise specified.

This warranty does not cover the failure or damage caused by:

- Transport not carried out by the Company.
- No compliance with instructions and warnings provided by the manufacturer and reported on manuals, and instructions and/or product catalogues.
- No compliance with law and/or regulations.
- Absence or lack of maintenance, neglect, inability to use, tampering.
- Improper installation and/or anomalies of any nature in the supply of hydraulic, electrical, fuel delivery and/or exhaust systems.
- Inadequate water treatments, disinfecting treatments improperly carried out.
- Corrosion due to the aggressive nature of water or condensation.
- Frost, stray currents, and/or harmful effects of lightning and storms.
- Preventive replacements.
- Causes of force majeure beyond the control of the manufacturing Company.

Any defect in materials or hidden faults as well as mistakes or differences in dimensions exceeding normal manufacturing tolerances will commit the Company to the replacement of defective parts only.

Any return of non-conforming goods will be accepted only with prior written authorization ("Return Authorization") by the Company's Sale Manager.

In any case the returned goods shall have to reach the Company's warehouse freight paid, otherwise the goods will be rejected and returned to the sender.

Any return of non-compliant material must be agreed in advance with the Company's Sale Director. Transport costs will be borne by the customer.

The insurance cover has the duration of 10 years from the date of shipment from the Company's premises, as contemplated in the Decree 24-05-1988 n°224.

Only in the case of the implementation of non-conforming products manufactured by the Company and as a result, accidental damages to person or things, the Company will require their insurance agency to proceed according to its policy. The claim has to be placed within 10 days of the event, otherwise a non-compensation penalty will apply.

A specific questionnaire including all the accident details, relevant documentation, and samples of the faulty articles which are necessary to complete the compensation file must be duly filled within 30 days.

No refund will be granted before the Company has verified the causes of the complaint.

Should laboratory tests be necessary, the costs incurred whilst checking and defining the non-conformity of a claim or return or damage will be charged to the customer if the fault cannot be attributed to the Company.

Installers are to carry out and document plant tests in compliance with international regulations in force in Italy as prescribed by the Ministerial Decree 37/08 and UNI 9182 standards.

ORDERS

All orders are placed as reservation and do not bind our Company to delivery, not even partially. Orders will be accepted and despatched only if in an amount exceeding 700 €.

PRICES

Unless otherwise agreed in writing the prices in force at the time of delivery or shipment shall apply.

Prices are meant for goods delivered EX WORKS.

SHIPMENTS

Goods are usually shipped freight collect, unless otherwise agreed. Goods travel at buyer's risk even if sold free of carriage .

PAYMENTS

Payment conditions are those stated in the invoice and are binding. Upon the expiration date of agreed deadlines, without any notice, interests on arrears calculated according to the average bank rate applied to the date of expiry shall be counted.

Any draft or payment fees will be at full client's charge.

CLAIMS

No claim will be accepted after 5 days upon goods receipt. Claims shall be submitted in writing and addressed to our headquarters.

RETURNED GOODS

No returned goods will be accepted without our previous authorization. The authorization must be issued in writing and goods are, in any case, returned carriage paid.

SUSPENDED ORDERS AND FORCE MAJEURE

If the buyer does not comply, even partially with our terms of sale, our company can suspend further deliveries.

Our company is exempt from any obligation arising from the sale agreement in case of force majeure.

CHANGES

Our company reserves the right to make, without notice, any changes that are technically necessary at any time and for any reason.

Images included in this catalogue are shown for information purposes only and they do not bind the Company which reserves the right to make changes without prior notification.

COURT OF JURISDICTION

In the event of a dispute, the competent authority is the Court of Brescia.

INTEGRATED COMPONENTS AND SYSTEMS FOR PLUMBING PLANTS



HYDRO COMPONENTS



CENTRAL HEATING - METERING



RADIANT SYSTEMS



FAUCETS

