

# PROTECTOR PRIME

---

A robust mobile filling and rinsing device preparing the system for ideal quality water levels.



[WWW.IWTM-UK.COM](http://WWW.IWTM-UK.COM)

T: +44 208 255 2903

E: [INFO@IWTM-UK.COM](mailto:INFO@IWTM-UK.COM)

# TABLE OF CONTENTS

---

- 03 PROTECTOR PRIME DESCRIPTION
- 04 DEMINERALISATION
- 06 INTERNAL AND EXTERNAL VIEW
- 07 FILLING AND RINSING RESIN REQUIREMENTS
- 08 MEASUREMENTS
- 10 INITIAL FILLING AND REPLACING RESIN
- 11 OPERATING THE CONDUCTIVITY / TDS METER
- 12 FILLING & RINSING SYSTEMS (DIAGRAM)
- 13 ACCESSORIES

# PROTECTOR PRIME DESCRIPTION

## WHAT IS IT?

The Protector Prime uses the same technology as our fixed ProFill units and is based on either the 12.5 or 25 Litre model. It is used for the initial demineralised filling of heating and cooling systems or for resin rinsing when remedial cleaning of systems previously treated with chemicals is required. Installed in line with the water supply to fill the system, Protector Prime ensures that when used with our controlled pH resin, the filling water is supplied in accordance with the VDI 2035 standard which is endorsed by CIBSE and SWKI BT102–01 Switzerland guideline and the Norm H 5195–1 Austrian guideline. When used for resin rinsing systems it is connected to either the flushing by-pass valve that is supplied with all our Protector units or other convenient flushing points on the system.

## HOW DOES IT WORK?

There is a water meter that is used to record the initial filling volume which can be recorded for future service records. Recording the meter reading before and after each resin change will inform you about the resin lifespan. The meter is also used to record the system volume that has been rinsed when carrying out remedial cleaning, the increasing volume of water that passes before the resin expires provides a good indicator of how the system water quality is improving.

The digital conductivity meter that can either record uS/cm or TDS has an inlet and outlet sensor, when filling it provides the starting conductivity of the incoming mains water supply and the outlet conductivity is monitored to maintain the required conductivity for the system requirements, the increasing conductivity reading on the outlet is an indicator that the resin is expiring. When rinsing systems, the lowering level of the inlet conductivity is the indicator that the system water quality is improving.

Although the Protector Prime can be used at the high pressure of 10 bar and high temperature of 95°C it should be noted that the resin power/life expectancy above 60°C is reduced by around 25%. We recommend lowering the temperature of the system when resin rinsing to prolong the life of the resin. All resin used for rinsing should be disposed of under environmental control procedures as it will contain system debris and chemical residue which is stripped from the system and encapsulated within the resin for safe disposal.

The Protector Prime operates through the process of demineralisation, where water flows over the ion exchange resin, and through this process, becomes demineralised water suitable for heating and cooling systems.

Please go to page 05, for the science behind demineralisation.



# WHY DO WE DEMINERALISE THE FILLING WATER OF HEATING & COOLING SYSTEMS?

Modern heating systems are sensitive to hard and corrosive filling water. Increased heating loads and more compact heat exchangers result in higher surface temperatures and thus in the formation of limescale build-up, which then prevents a good heat transfer and could limit the efficiency or lead to premature failures and malfunctioning of the system. In addition, materials such as aluminium or stainless steel are also very sensitive when it comes to an improper composition of the water.

For these reasons, many heating and cooling equipment manufacturers require the use of conditioned filling water, the most common to ensure compliance with the guideline VDI 2035 part 1.

The main aim of Guideline VDI 2035 is to prevent scale formation and water-side corrosion damage.

To reach these goals, the Guideline foresees different procedures, demineralisation, hardness stabilisation, and stabilisation of the pH and is applicable to the process of heating water conditioning for water heating installations in accordance with DIN EN 12828 within buildings when the flow temperature does not exceed 100°C.



Limescale on surfaces lead to high temperature differences in the heat exchanger itself - thermal stress causes cracks with leaks.



Lime scale in a heating pipe, significant reduction in diameter.

# PROCESS OF DEMINERALISATION

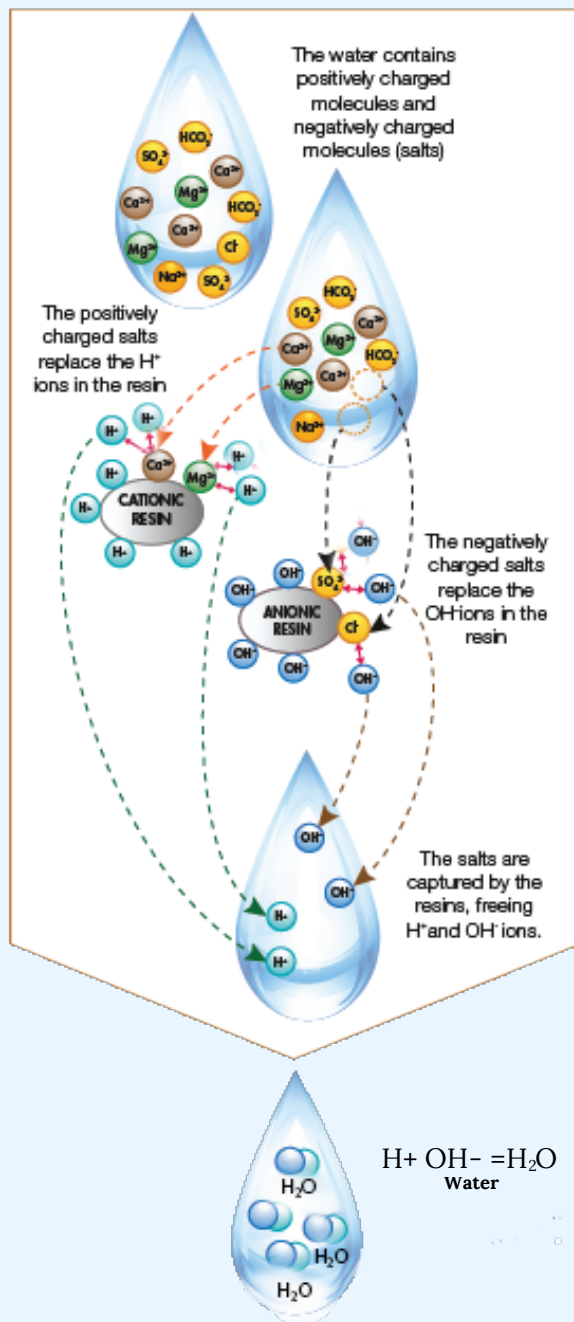

The resin beads have two types of ion exchange with the untreated water. As the untreated water passes through the Protector Prime, positively charged ions from the water will swap with positive hydrogen ions on the resin (cation exchange) .

Similarly, negative ions in the untreated water will swap with negative hydroxyl ions on the resin beads (anion exchange).

The ions will be exchanged until none is left in the water other than hydrogen and hydroxyl ions, making H<sub>2</sub>O, demineralised water.

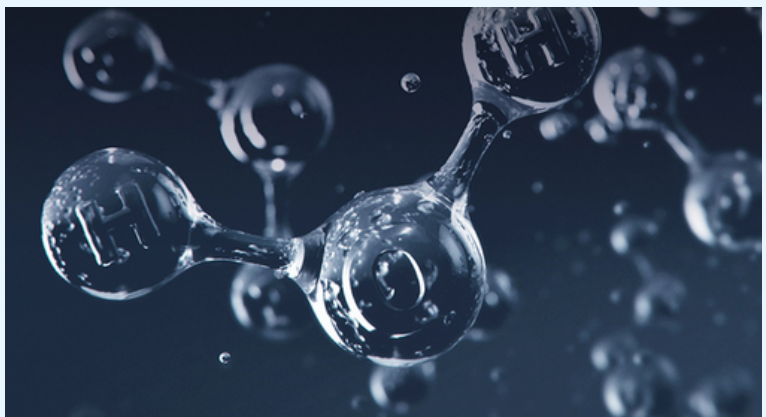
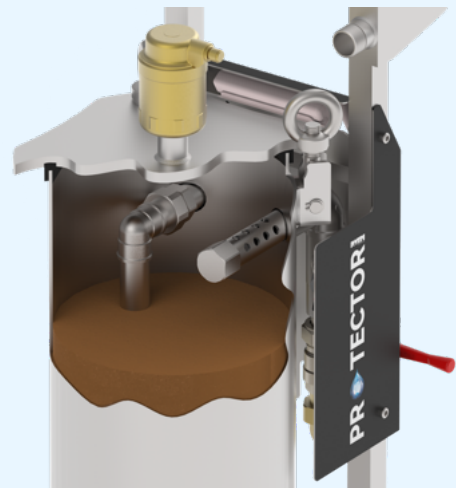

# INTERNAL & EXTERNAL VIEW

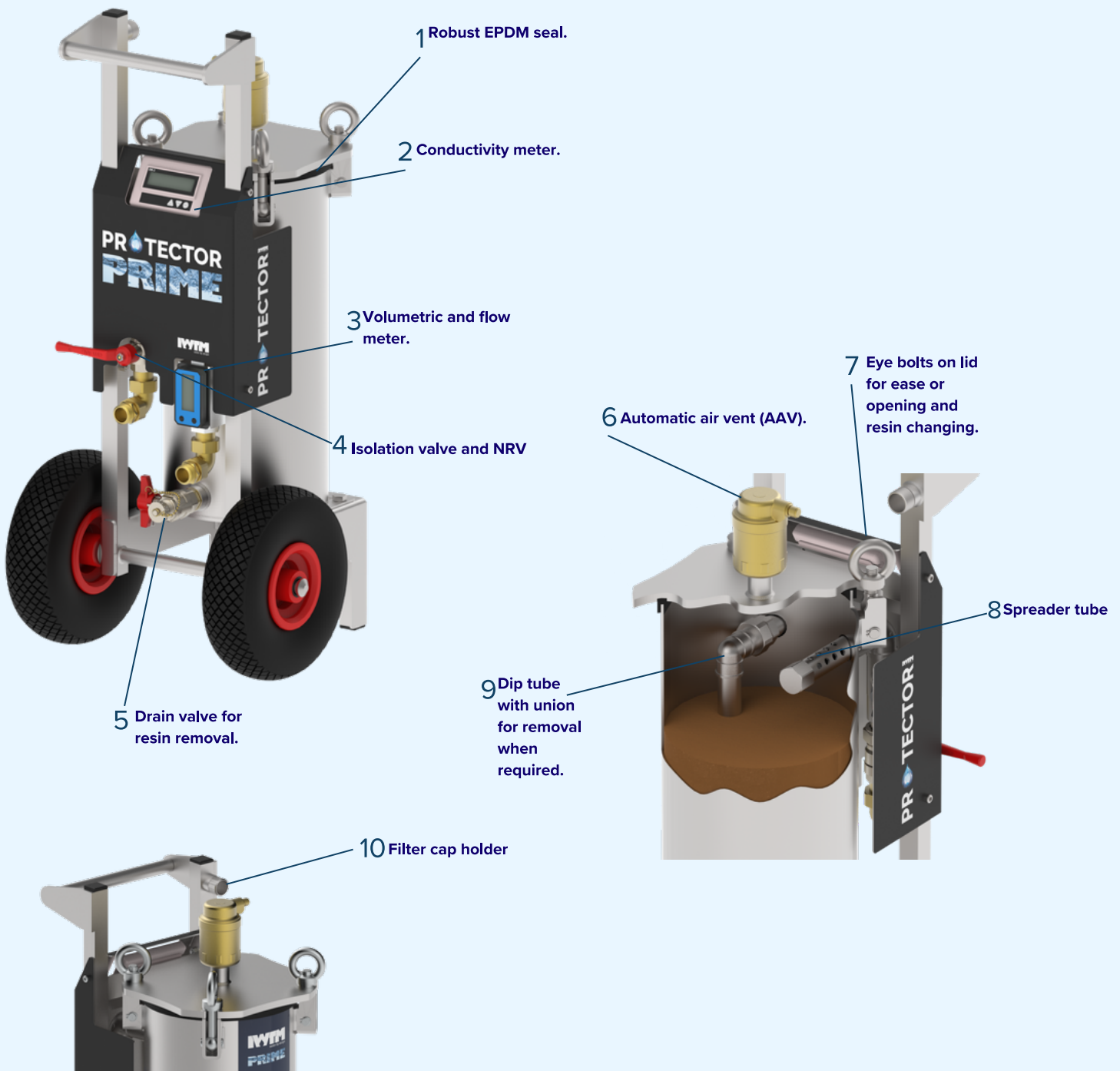

# FILLING AND RINSING RESIN REQUIREMENTS

## FILLING THE SYSTEM

The amount of resin required to fill a system using the Protector Prime will be determined by two factors:

1. Where in the country the filling is taking place as this will change the hardness of the incoming water and this will change the life expectancy of the resin.
2. The actual system volume.

When you know the incoming water hardness using the chart below it will provide you with a guide to how many litres of demineralised water 12.5 litres of resin can provide, you can then calculate how many litres of resin you will require for your project.

## RESIN RINSING

It is impossible to accurately calculate how much resin will be required to resin rinse a system as no two systems are the same, the things that can affect how much resin is required are as follows:

- Existing conductivity and chloride levels.
- Levels of corrosion & bacteria present
- Chemical composition of system water
- Levels of chemical present (inhibitors, biocides etc)

Please contact us with your system details and current water quality results and we will be able to offer you some guidance on the expected amount of resin needed.

You can find your water company and then your water hardness guide from your local water provider.  
<https://www.water.org.uk/advice-for-customers/find-your-supplier/>

	2 °dH	7 °dH	15 °dH
<b>Prime 12.5L</b>	10,000	2,857	1,333
<b>Prime 25L</b>	20,000	5,714	2,666

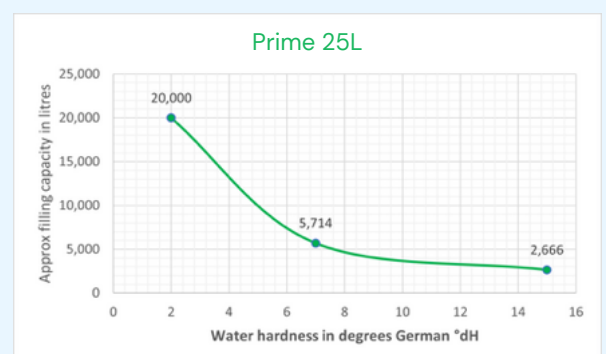
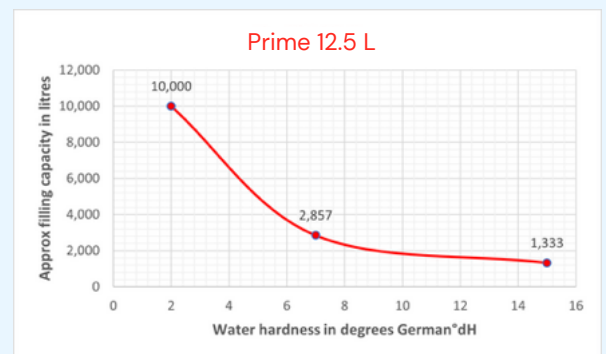
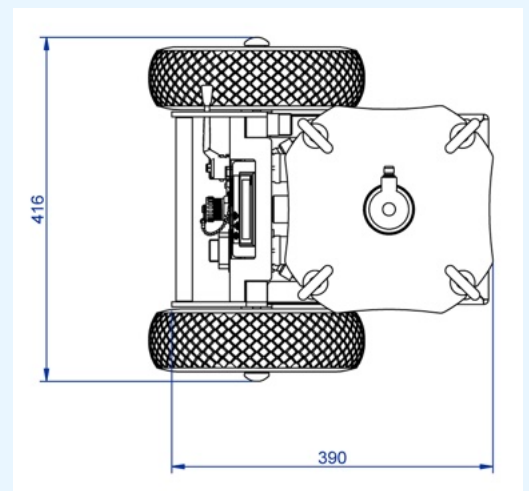
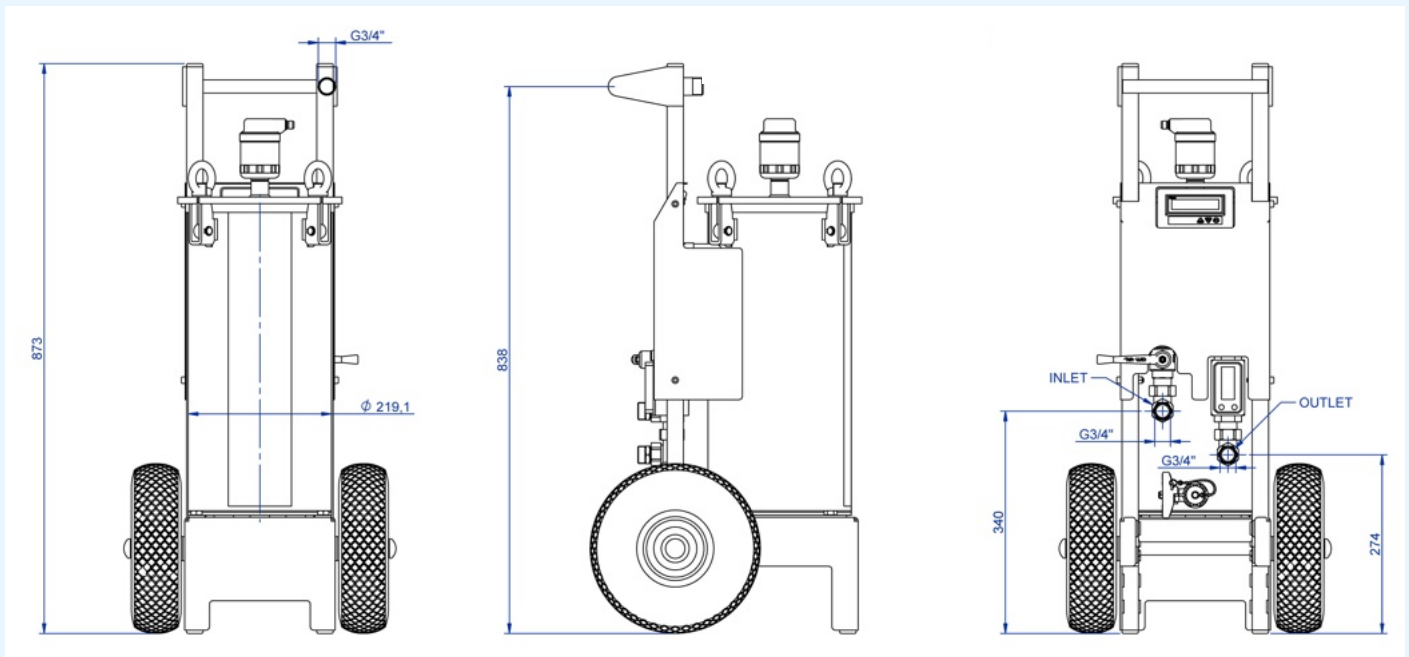

Table showing what the approximate filling capacity in litres is with different water hardness in degrees German °dH.



# 12.5L MEASUREMENTS

Unit	Max Pressure	Max Temp	Delivery Capacity	Height	Width	Depth	Weight
<b>Protector Prime 12.5L</b>	10 bar	95°C	20 l/min	873 cm	416 cm	390 cm	32.4 kg





# 25L MEASUREMENTS

Unit	Max Pressure	Max Temp	Delivery Capacity	Height	Width	Depth	Weight
<b>Protector Prime 25L</b>	10 bar	95°C	20 l/min	1173 cm	416 cm	410 cm	40 kg

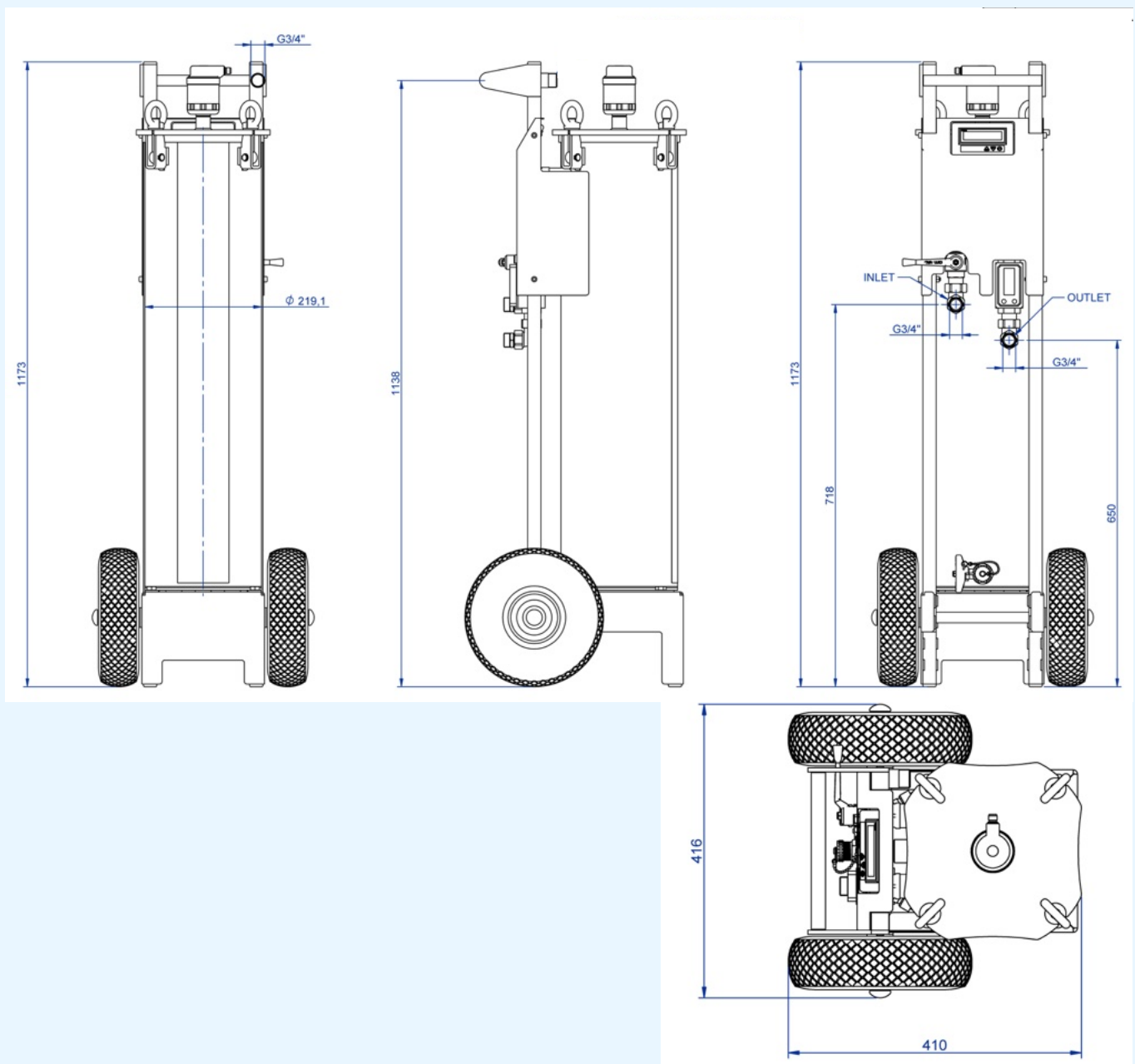

# INITIAL FILLING & REPLACING RESIN

## INITIAL FILLING

1. Undo eye bolts and remove the lid and seal.
2. Pour in the new resin. Replace the seal ensuring there is no resin on the seal.
3. Replace the lid and tighten eye bolts.
4. Open the inlet valve and automatic air vent. When all air is dispensed open the outlet valve.
5. Record the water meter reading
6. Check the lid is sealed and water tight.

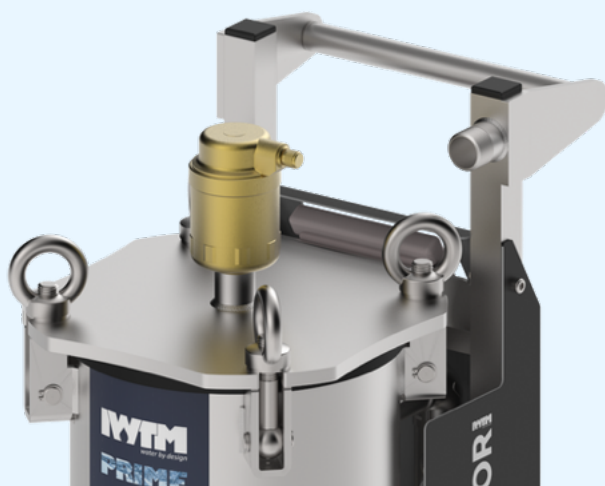

## REPLACING THE RESIN

1. Close ball valve in the outlet, connect a hose at the drain valve and route into the supplied collection sack; flush out the resin at mains pressure. Close the inlet valve and drain water, and close drain valve.
2. Continue by following steps 1-6 'Initial Filling'

## TRANSPORTATION

When you have finished a project and you still have useable resin within the Prime, fit the filter drain cap supplied with the Prime. Open the drain valve to partially drain the water from the unit, ensuring the resin remains covered by water, before transportation.



# OPERATING THE CONDUCTIVITY / TDS METER

## OPERATION

1. Press the POWER (ENT) button to turn on.
2. Press the UNIT button to turn on the back light and swap between TDS and uS/cm
3. Read the IN (Line 1) and OUT (Line 2) to see your conductivity/TDS levels

## CALIBRATION

The unit is factory calibrated to 342ppm (NaCl). Like all monitoring devices from time to time the unit will require recalibration, check the calibration against a calibrated hand-held device, if the readings on the DM-3 are different then the unit should be recalibrated.

1. With the ProFill mobile disconnected from the system and drained down, remove the sensors from the branch connection by undoing the retaining nut.
2. Put the sensor into calibration solution alongside and calibrated hand-held device.
3. Turn on the DM-3 monitor.
4. Press and hold the CAL (Calibration) key for 5 seconds to display calibration mode.
5. Select between L1 (Line 1) and L2 (Line 2) by pressing the CAL key, confirm by pressing ENT key.
6. The measurement value will flash on the display. Adjust the reading as required with the ▲ and ▼, press the ENT button to start the calibration. You can cancel the calibration at any time by pressing the ENT button twice during the calibration process.
7. End will display on the screen when the calibration is completed.

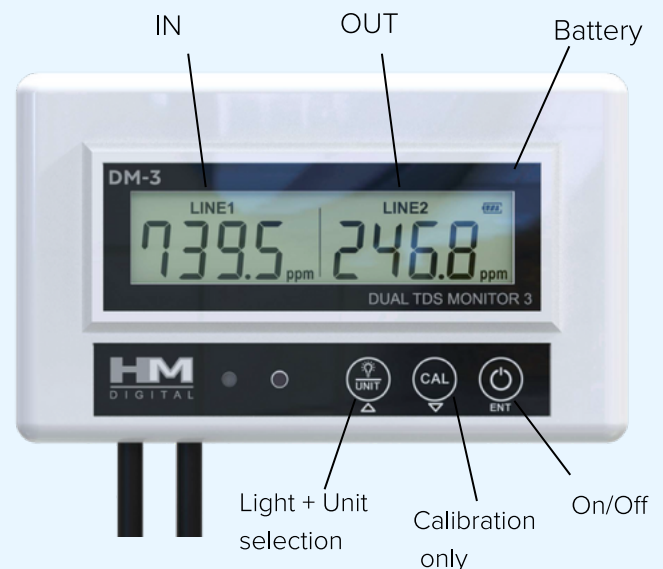

## CHANGING THE BATTERIES

If the batteries are low, the low battery indicator will be blinking.

1. To replace the batteries, unscrew the four metal screws on the rear of the unit and remove the back panel.
2. Remove the old batteries.
3. Replace with 2x AA batteries, ensuring the polarity is correct.
4. Close the back panel and replace the screws.  
You will not need to recalibrate.

## TROUBLESHOOTING

<u>Issue</u>	<u>Potential Solution</u>
Display <b>Err</b>	The sensor cable is not connected. Open the back panel and connect the cable securely.
Display <b>oor</b>	The water is out of the monitor's TDS range.
Display <b>bAt</b>	Change the batteries
The 'OUT' reading is higher than the 'IN' reading	Check your connections. The sensors may be reversed.

# FILLING AND RINSING SYSTEMS DIAGRAM

## FILLING

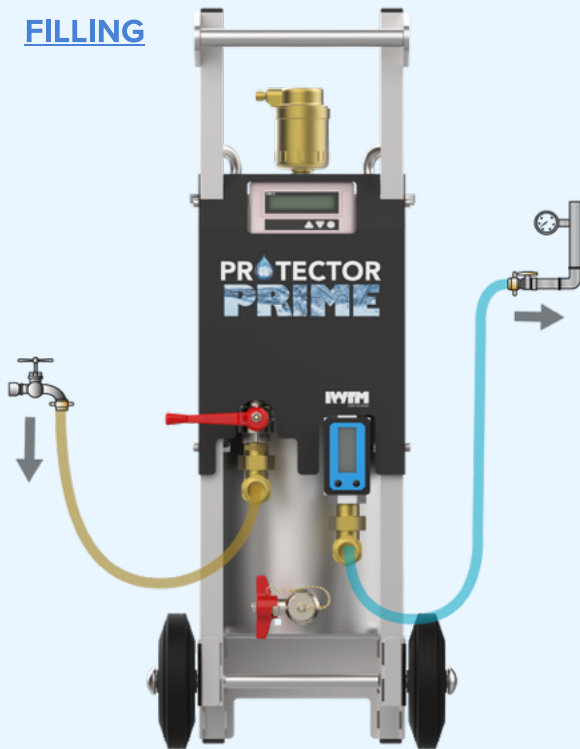

Connection principle only, ensure local water authority guidelines are followed.

## RINSING

Shown connected to the flushing by-pass supplied with the Protector.



# ACCESSORIES

Part No.	Description
<b>PRIME - Complete Unit</b>	
FVPROF002	PROTECTOR PRIME 12.5L
FVPROF003	PROTECTOR PRIME 25L
<b>PRIME - Spare Parts</b>	
CDGRN0005	HOUSING GASKET Ø273 (EPDM)
CASCM0016	AIR VENT
DM-3	CONDUCTIVITY METER INC SENSORS
<b>PRIME - Ion Exchange Resin</b>	
201651	PRIME PH RESIN
200922	PRIME RESIN



# Environmental Culture Change

*be a part of it*

clean | protect | prevent



**LETTER OF COMPLIANCE  
CLEAN MARITIME  
MACHINERY AND COMPONENTS**

COMPLIANCE LETTER NO. 1

*This is to certify that the*

**Water Treatment Units**

*with type designations*

**Elysator 15, 25, 50, 75, 100, 260, 500, 800 and 1000L**

*Manufactured by*

**International Water Treatment Maritime AS**

**SLEMMESTAD, Norway**

*is found to comply with*

Det Norske Veritas' Standards for Certification 2.17 (new), Standard for CLEAN Maritime Machinery and Components

HØVIK  
June 4<sup>th</sup> 2003

  
for Morten Østby  
Project Responsible

  
Tor Jø Landheim  
Project Manager

DET NORSKE VERITAS

Founded in 1992, IWTM have been working with chemical free water treatment using electrochemistry for over 30 years and have offices in Norway, UK, Finland, Sweden, Canada, USA and a worldwide presence in the Marine sector.

We have developed models specifically suited to the higher demands of the marine industry operating at higher pressures and higher temperatures. The marine products are provided worldwide on the world's largest cruise ships working with the leading operators in this sector.

Having secured DNV approval in 2003, we are still the only chemical free water treatment manufacturer to have this certification and approval. DNV is a globally leading quality assurance and risk management company operating in more than 100 countries.

The IWTM Protector™ is our most recently developed product. The Protector range is now available to our land-based customers.

Version 1: October 2023

70 St Laurences Park,  
Stillorgan,  
Co.Dublin

[www.ecopipe.ie](http://www.ecopipe.ie)

T: +353 1 210 9970

E: [sales@ecopipe.ie](mailto:sales@ecopipe.ie)